

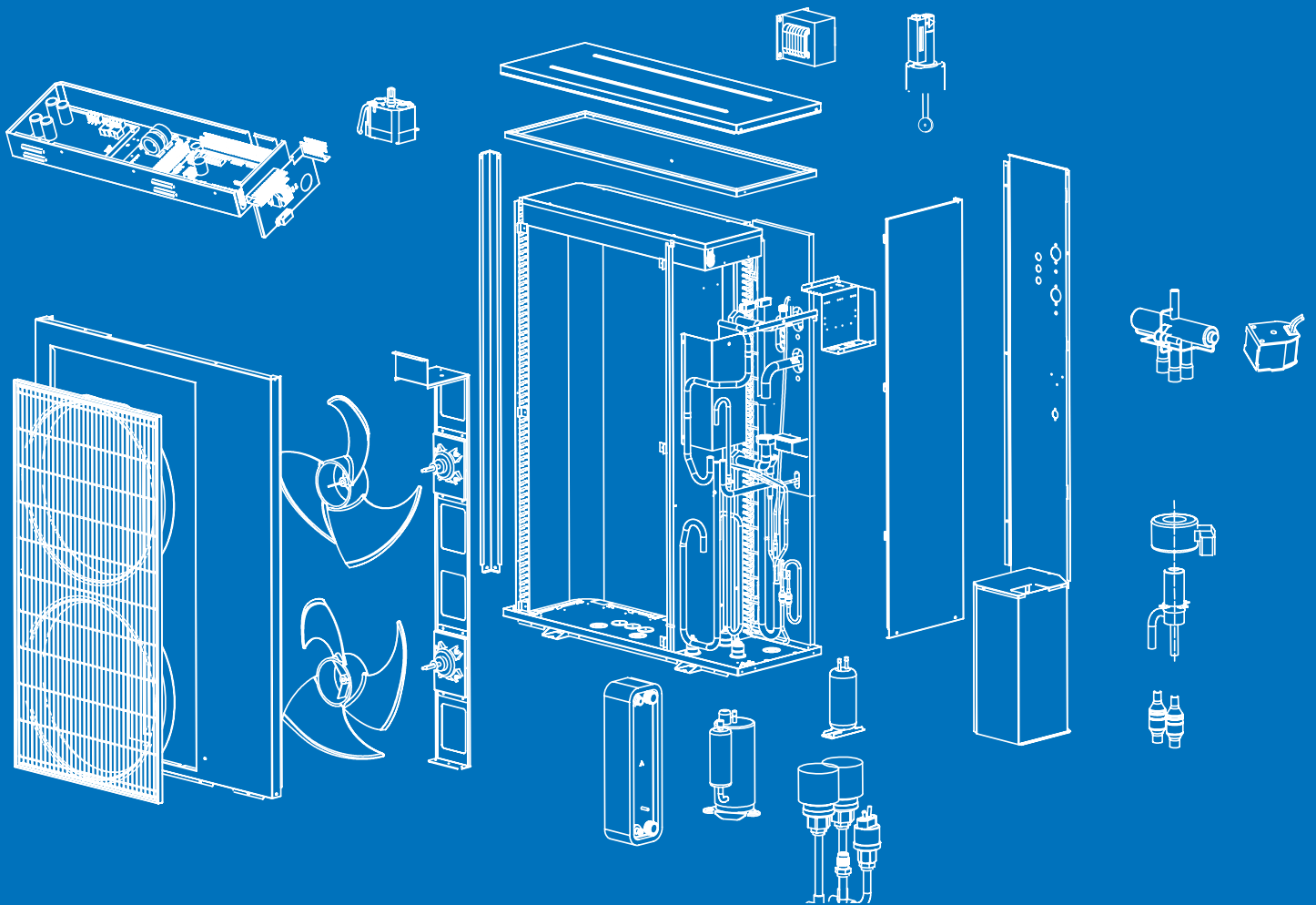

**HEAT TECHNOLOGY MANUFACTURER**



# Katalóg náhradných dielov

Katalog náhradních dílů - Spare parts catalogue - Ersatzteilkatalog  
Catalog de piese de schimb - Alkatrész katalógus

# 2023



[www.attack.sk](http://www.attack.sk)



ATTACK INVERTER R32

3 - 7



ATTACK DPX STANDART, PROFI, LAMBDA, COMBI PELLETT  
ATTACK SLX PROFI, LAMBDA TOUCH

8- 21  
22 - 43



ATTACK PELLETT 30 AUTOMATIC PLUS

44 - 51



ATTACK WOOD&PELLETT

52 - 59



ATTACK FD, FD AUTOMAT  
ATTACK PELLETT BURNER AUTOMATIC, BIOHEAT, PEL, PED,  
ATTACK PV150  
ATTACK FD SOLID FIRE  
ATTACK DP STANDART, PROFI

60 - 63  
64- 71  
72  
73  
74 - 81



ATTACK CONDENSING KT, KST, KZT  
ATTACK CONDENSING KT 50 -150kW  
ATTACK KST, KZT, KT, KT SMALL  
ATTACK RZK

82 - 87  
88 - 93  
94 - 99  
114 - 116



ATTACK EKO, PLQ, KLV, KLQ, E, EZ  
ATTACK SV

100 - 113  
111



ATTACK EASY, EXCELLENT

117 - 119



ATTACK 100Z, PZO PLUS

120 - 122

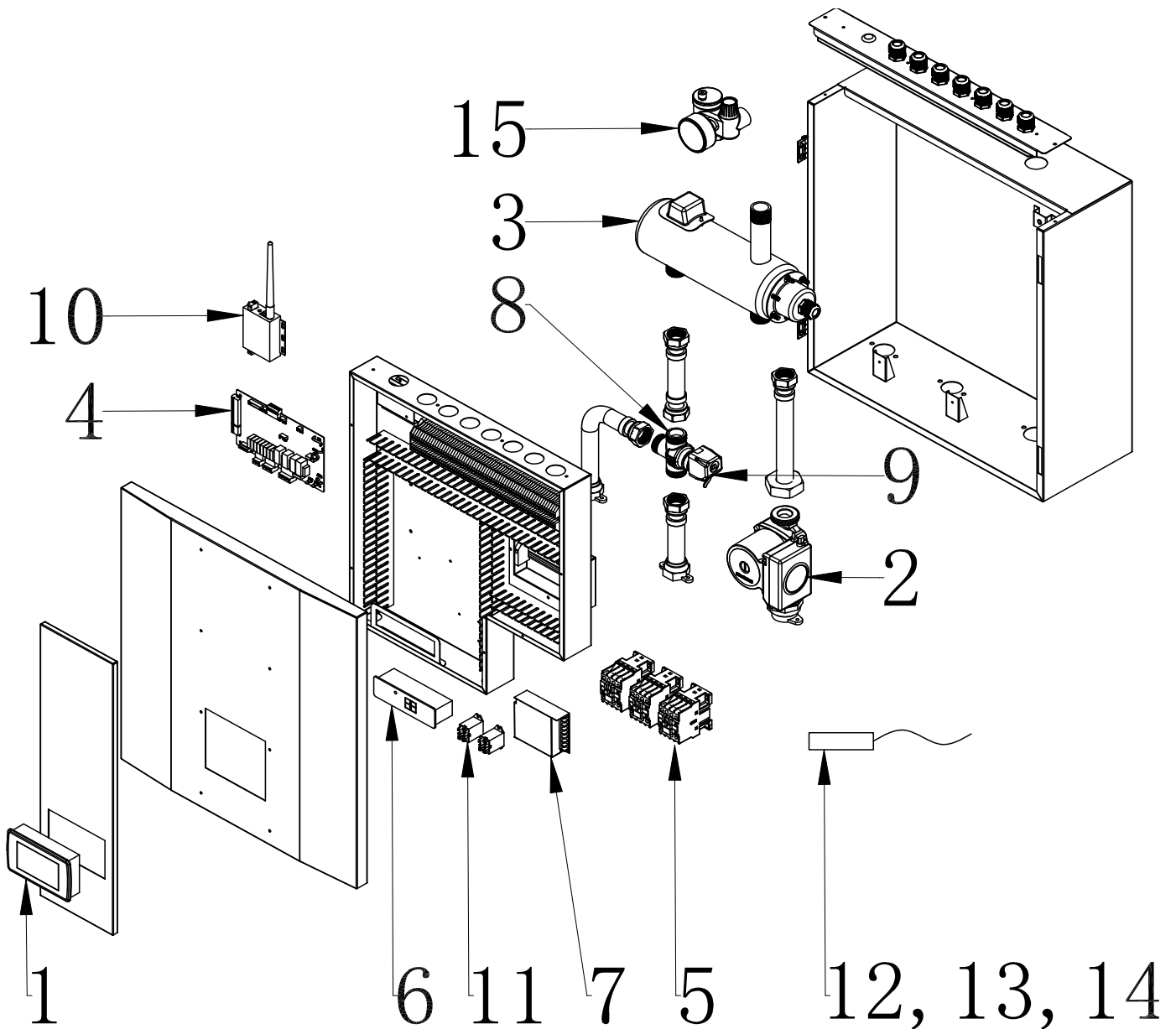

INDOOR UNIT				
#	CODE	SERIAL NUMBERS ONLY		
1	TC143		Operation panel Eco Touch - 6/9/12/15/19 kW	Dotykový ovládací panel Eco Touch - 6/9/12/15/19 kW
2	TC144		Water pump Grundfos - 6/9/12/15/19 kW	Obehové čerpadlo Grundfos - 6/9/12/15/19 kW
3	TC198	TCO2116060001 - TCO2116060004, TCO2116090001 - TCO2116090008, TCO2116120001 - TCO2116120009, TCO2116150001 - TCO2116150004, TCO2116190001 - TCO2116190004, TCI2116060001 - TCI2116060004, TCI2116090001 - TCI2116090008, TCI2116120001 - TCI2116120009, TCI2116150001 - TCI2116150004, TCI2116190001 - TCI2116190004	Electrical heater 3kW (container + inner tubes) - 6/9/12/15/19 kW	Elektrický ohrievač 3 kW (nádobu + vnútorné rúrky) - 6/9/12/15/19 kW
			Electrical heater 6 kW (container + inner tubes) - 6/9/12/15/19 kW	Elektrický ohrievač 6 kW (nádobu + vnútorné rúrky) - 6/9/12/15/19 kW
4	TC145		Indoor PCB - 6/9/12/15/19 kW	Riadiaca elektronika vnútornej jednotky - 6/9/12/15/19 kW
5	TC171		3 Phase AC Contactor	Stykač 3 fázový
6	TC158		Digital Thermostat (AH) - 6/9/12/15/19 kW	Digitálny termostat - 6/9/12/15/19 kW
7	TC172		Power Switch	Zdroj 230AC/24DC
8	TC146		Electric 3-way valve (WATTS) - 6/9/12/15/19 kW	Teleso trojcestného ventilu wATS - 6/9/12/15/19 kW
9	TC147		Electric 3-way valve Coil (WATTS) - 6/9/12/15/19 kW	Pohon trojcestného ventilu WATS - 6/9/12/15/19 kW
10	TC191		Wifi module	Wifi modul
11	TC192		Relay	Relé
12	TC193		Tc / Tw temp sensor	Sada teplotných snímačov
13	TC194		Indoor coil temp sensor	Vnútorný snímač teploty cievky
14	TC195		Room temp sensor	Snímač izbovej teploty
15	TC202		Safety Kit	Bezpečnostná súprava

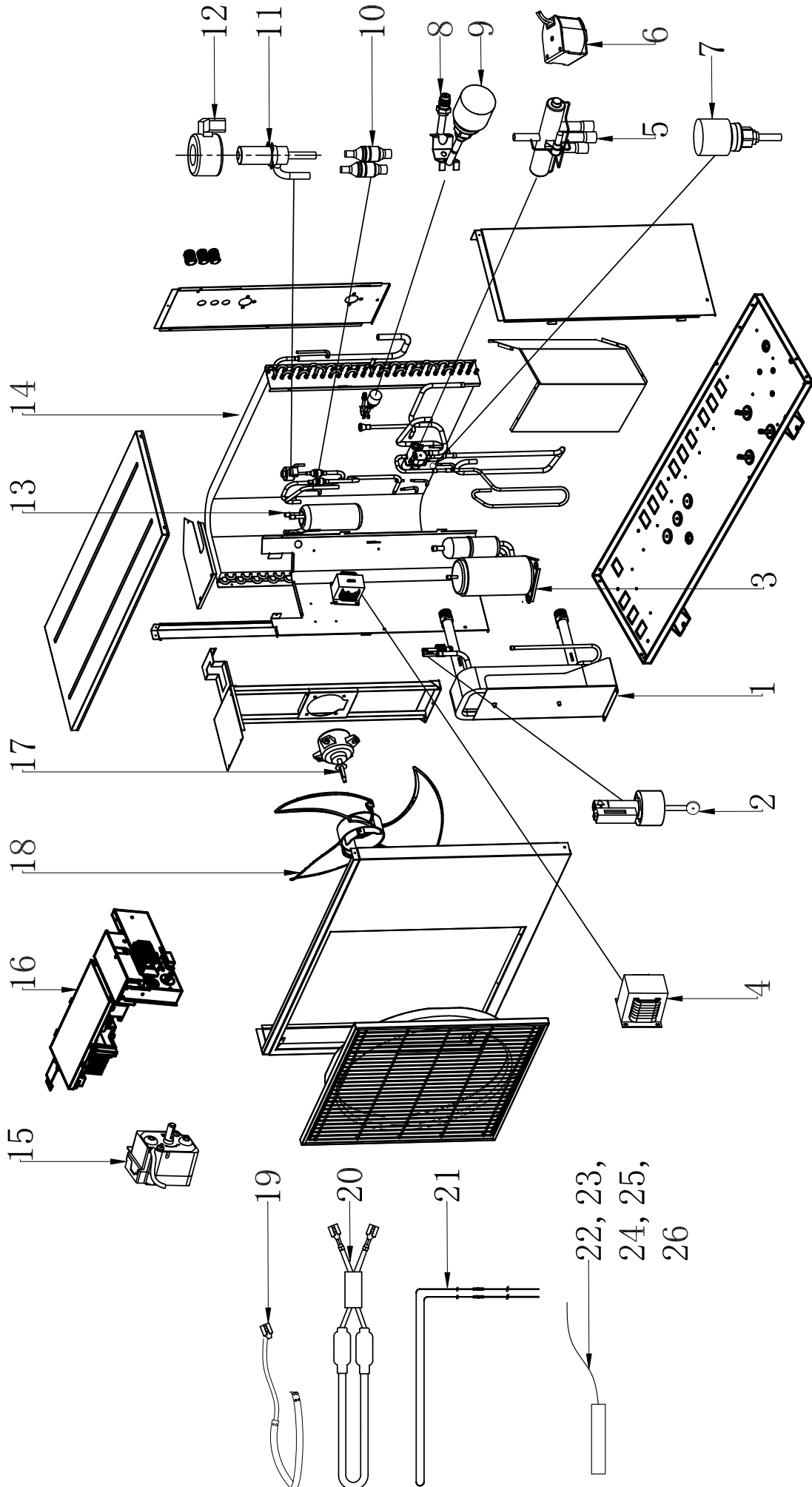

TCI09		SERIAL NUMBERS ONLY	
#	CODE		
1	TCI05	Plate Heat Exchanger - 9kW	Doskový výmenník tepla - 9 kW
2	TCI84	Water flow switch - 6/9 kW	Spínač prítoku 6/12 kW
3	TCI64	Compressor - 9 kW	Kompresor - 9 kW
4	TCI16	Transducer - 6/9/12 kW	Transformátor - 6/9/12 kW
5	TCI17	4-way valve - 6/9/12 kW	Štvorcestý ventil - 6/9/12 kW
6	TCI18	Coil of 4-way valve - 6/9/12 kW	Cievka štvorcestného ventilu - 6/9/12 kW
	TCI189	Coil of 4-way valve - 6/9/12 kW	Cievka štvorcestného ventilu - 6/9/12 kW
7	TCI19	High pressure sensor - 6/9/12/15/19 kW	Vysoko tlakový snímač - 6/9/12/15/19 kW
8	TCI42	Service valve - 6/9/12/15/19 kW	Servicevalv - 6/9/12/15/19 kW
9	TCI20	Low pressure sensor - 6/9/12/15/19 kW	Nízko tlakový snímač - 6/9/12/15/19 kW
10	TCI69	Filter - 6/9/12/15/19 kW	Filter - 6/9/12/15/19 kW
11	TCI12	EEV - 9/12 kW	EEV - 9/12 kW
12	TCI21	Coil of EEV - 6/9/12 kW	Cievka EEV - 6/9/12 kW
13	TCI54	Gas storage tank - 6/9 kW	Zásobník plynu - 6/9 kW
14	TCI51	Evaporator coil - 9 kW	Výparník - 9 kW
15	TCI22	Thermostat of PHE anti-free heater - 6/9/12/15/19 kW	Termostat protizamrazového systému - 6/9/12/15/19 kW
16	TCI74	Outdoor controller - 9 kW	Riadiaca elektronika - vonkajšia jednotka - 9 kW
17	TCI15	Fan motor - 6/9/12/15/19 kW	Motor ventilátora - 6/9/12/15/19 kW
18	TCI55	Fan blower (Ø550x124) - 9/12/15/19 kW	Vrtuľa ventilátora (Ø550x124) - 9/12/15/19 kW
19	TCI23	Compressor crankcase heater - 6/9/12 kW	Ohrievač kompresora - 6/9/12 kW
	TCI96	Compressor crankcase heater - 9/12 kW	Ohrievač kompresora - 9/12 kW
20	TCI86	Bottom plate heater - 6/9/12 kW	Drtový ohrievač spodnej vaničky - 6/9/12 kW
21	TCI25	PHE anti-free heater - 6/9/12 kW	Ohrievač doskového výmenníka - 6/9/12 kW
22	TCI75	Water inlet temp sensor - 6/9/12 kW	Snímač teploty prívodu vody - 6/9/12 kW
23	TCI88	Water outlet temp sensor 6/9/12 kW	Snímač teploty výstupu vody 6/9/12 kW
24	TCI27	Indoor coil temp sensor (in PHE) - 6/9/12 kW	Snímač teploty výmenníka - 6/9/12 kW
25	TCI76	Compressor discharge temp sensor - 6/9/12 kW	Snímač teploty výfuku kompresora - 6/9/12 kW
26	TCI77	Compressor suction temp sensor - 6/9/12 kW	Snímač teploty nasávania kompresora - 6/9/12 kW

TCI06		SERIAL NUMBERS ONLY	
#	CODE		
1	TCI04	Plate Heat Exchanger - 6 kW	Doskový výmenník tepla - 6 kW
2	TCI84	Water flow switch - 6/9 kW	Spínač prítoku 6/12 kW
3	TCI68	Compressor - 6 kW	Kompresor - 6 kW
4	TCI16	Transducer - 6/9/12 kW	Transformátor - 6/9/12 kW
5	TCI17	4-way valve - 6/9/12 kW	Štvorcestý ventil - 6/9/12 kW
6	TCI18	Coil of 4-way valve - 6/9/12 kW	Cievka štvorcestného ventilu - 6/9/12 kW
	TCI189	Coil of 4-way valve - 6/9/12 kW	Cievka štvorcestného ventilu - 6/9/12 kW
7	TCI19	High pressure sensor - 6/9/12/15/19 kW	Vysoko tlakový snímač - 6/9/12/15/19 kW
8	TCI42	Service valve - 6/9/12/15/19 kW	Servicevalv - 6/9/12/15/19 kW
9	TCI20	Low pressure sensor - 6/9/12/15/19 kW	Nízko tlakový snímač - 6/9/12/15/19 kW
10	TCI69	Filter - 6/9/12/15/19 kW	Filter - 6/9/12/15/19 kW
11	TCI13	EEV - 6 kW	EEV - 6 kW
12	TCI21	Coil of EEV - 6/9/12 kW	Cievka EEV - 6/9/12 kW
13	TCI54	Gas storage tank - 6/9 kW	Zásobník plynu - 6/9 kW
14	TCI50	Evaporator coil - 6 kW	Výparník - 6 kW
15	TCI22	Thermostat of PHE anti-free heater - 6/9/12/15/19 kW	Termostat protizamrazového systému - 6/9/12/15/19 kW
16	TCI00	Outdoor controller - 6 kW	Riadiaca elektronika - vonkajšia jednotka 6 kW
17	TCI15	Fan motor - 6/9/12/15/19 kW	Motor ventilátora - 6/9/12/15/19 kW
18	TCI70	Fan blower (Ø496x139) - 6 kW	Vrtuľa ventilátora (Ø496x139) - 6 kW
19	TCI23	Compressor crankcase heater - 6/9/12 kW	Ohrievač kompresora - 6/9/12 kW
	TCI85	Compressor crankcase heater - 6 kW	Ohrievač kompresora - 6 kW
20	TCI86	Bottom plate heater - 6/9/12 kW	Drtový ohrievač spodnej vaničky - 6/9/12 kW
21	TCI25	PHE anti-free heater - 6/9/12 kW	Ohrievač doskového výmenníka - 6/9/12 kW
22	TCI75	Water inlet temp sensor - 6/9/12 kW	Snímač teploty prívodu vody - 6/9/12 kW
23	TCI88	Water outlet temp sensor 6/9/12 kW	Snímač teploty výstupu vody 6/9/12 kW
24	TCI27	Indoor coil temp sensor (in PHE) - 6/9/12 kW	Snímač teploty výmenníka - 6/9/12 kW
25	TCI76	Compressor discharge temp sensor - 6/9/12 kW	Snímač teploty výfuku kompresora - 6/9/12 kW
26	TCI77	Compressor suction temp sensor - 6/9/12 kW	Snímač teploty nasávania kompresora - 6/9/12 kW

TCI12		SERIAL NUMBERS ONLY	
#	CODE		
1	TCI06	Plate Heat Exchanger - 12 kW	Doskový výmenník tepla - 12 kW
2	TCI83	Water flow switch - 12 kW	Spínač prítoku 12 kW
3	TCI66	Compressor - 12 kW	Kompresor - 12 kW
4	TCI16	Transducer - 6/9/12 kW	Transformátor - 6/9/12 kW
5	TCI17	4-way valve - 6/9/12 kW	Štvorcestý ventil - 6/9/12 kW
6	TCI18	Coil of 4-way valve - 6/9/12 kW	Cievka štvorcestného ventilu - 6/9/12 kW
7	TCI89	Coil of 4-way valve - 6/9/12 kW	Cievka štvorcestného ventilu - 6/9/12 kW
8	TCI19	High pressure sensor - 6/9/12/15/19 kW	Vysoko tlakový snímač - 6/9/12/15/19 kW
9	TCI42	Service valve - 6/9/12/15/19 kW	Servicevalv - 6/9/12/15/19 kW
10	TCI20	Low pressure sensor - 6/9/12/15/19 kW	Nízko tlakový snímač - 6/9/12/15/19 kW
11	TCI69	Filter - 6/9/12/15/19 kW	Filter - 6/9/12/15/19 kW
12	TCI12	EEV - 9/12 kW	EEV - 9/12 kW
13	TCI53	Coil of EEV - 6/9/12 kW	Cievka EEV - 6/9/12 kW
14	TCI49	Gas storage tank - 12 kW	Zásobník plynu - 12 kW
	TCI97	Evaporator coil - 12 kW	Výparník - 12 kW
15	TCI22	Thermostat of PHE anti-free heater - 6/9/12/15/19 kW	Termostat protizamrazového systému - 6/9/12/15/19 kW
16	TCI73	Outdoor controller - 12 kW	Riadiaca elektronika - vonkajšia jednotka 12 kW
17	TCI15	Fan motor - 6/9/12/15/19 kW	Motor ventilátora - 6/9/12/15/19 kW
18	TCI55	Fan blower (Ø550x124) - 9/12/15/19 kW	Vrtuľa ventilátora (Ø550x124) - 9/12/15/19 kW
19	TCI23	Compressor crankcase heater - 6/9/12 kW	Ohrievač kompresora - 6/9/12 kW
	TCI96	Compressor crankcase heater - 9/12 kW	Ohrievač kompresora - 9/12 kW
20	TCI86	Bottom plate heater - 6/9/12 kW	Drtový ohrievač spodnej vaničky - 6/9/12 kW
21	TCI25	PHE anti-free heater - 6/9/12 kW	Ohrievač doskového výmenníka - 6/9/12 kW
22	TCI75	Water inlet temp sensor - 6/9/12 kW	Snímač teploty prívodu vody - 6/9/12 kW
23	TCI88	Water outlet temp sensor 6/9/12 kW	Snímač teploty výstupu vody 6/9/12 kW
24	TCI27	Indoor coil temp sensor (in PHE) - 6/9/12 kW	Snímač teploty výmenníka - 6/9/12 kW
25	TCI76	Compressor discharge temp sensor - 6/9/12 kW	Snímač teploty výfuku kompresora - 6/9/12 kW
26	TCI77	Compressor suction temp sensor - 6/9/12 kW	Snímač teploty nasávania kompresora - 6/9/12 kW

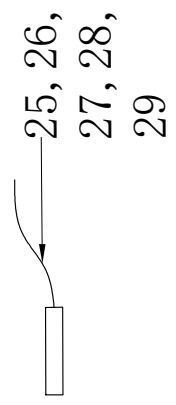
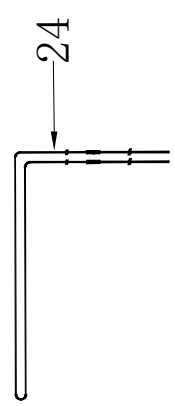
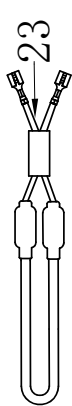
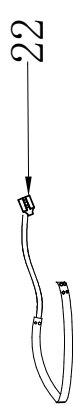
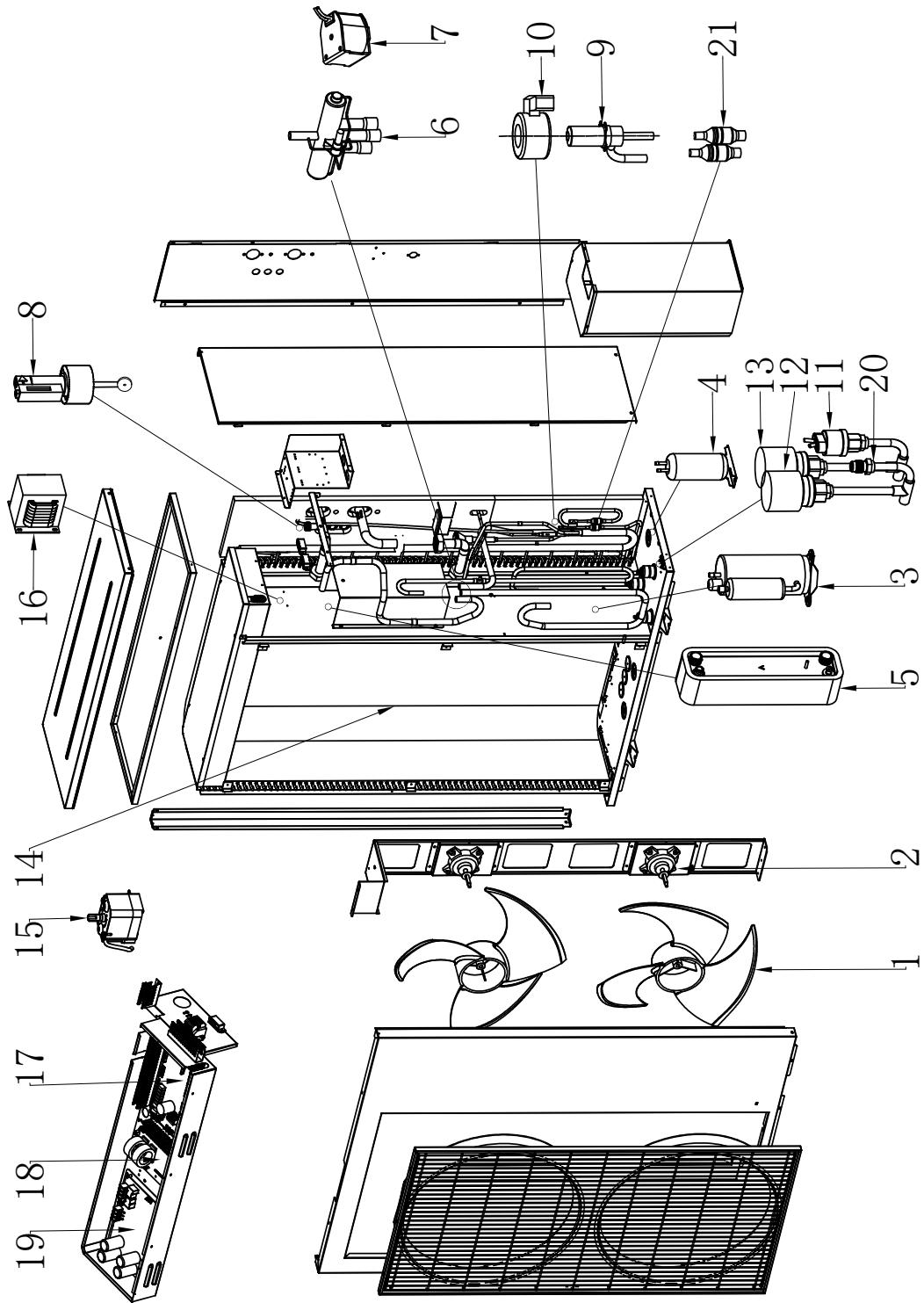

TC119		SERIAL NUMBERS ONLY	
#	CODE		
1	TC155	Fan blower (Ø550x124) - 9/12/15/19 kW	Vrtuľa ventilátora (Ø550x124) - 9/12/15/19 kW
2	TC115	Fan motor - 6/9/12/15/19 kW	Motor ventilátora - 6/9/12/15/19 kW
3	TC167	Compressor - 19 kW	Kompresor - 19 kW
4	TC152	Gas storage tank - 15/19 kW	Zásobník plynu - 15/19 kW
5	TC108	Plate Heat Exchanger - 19 kW	Doskový výmenník tepla - 19 kW
6	TC129	4-way valve - 15/19 kW	Štvorcestý ventil - 15/19 kW
7	TC130	Coil of 4-way valve - 15/19 kW	Cievka štvorcestného ventilu - 15/19 kW
8	TC110	Water flow switch - 15/19 kW	Spínač prítoku - 15/19 kW
9	TC114	EEV - 19 kW	EEV - 19 kW
10	TC131	Coil of EEV - 15/19 kW	Cievka EEV - 15/19 kW
11	TC132	High pressure switch - 15/19 kW	Spínač vysokého tlaku - 15/19 kW
12	TC120	Low pressure sensor - 6/9/12/15/19 kW	Nízko tlakový snímač - 6/9/12/15/19 kW
13	TC119	High pressure sensor - 6/9/12/15/19 kW	Vysoko tlakový snímač - 6/9/12/15/19 kW
14	TC162	Evaporator coil - 19 kW	Výparník - 19 kW
15	TC122	Thermostat of PHE anti-free heater - 6/9/12/15/19 kW	Termostát protizamrazového systému - 6/9/12/15/19 kW
16	TC133	Transducer - 15/19 kW	Transformátor - 15/19 kW
17	TC200	Transducer - 15/19 kW	Transformátor - 15/19 kW
18	TC101	Outdoor controller - 15/19 kW	Riadiaca elektronika vonkajšia jednotka - 15/19 kW
19	TC102	Translating print board - 15/19 kW	Prevodník vonkajšia jednotka - 15/19 kW
18	TC159	Compressor Driver Board - 15/19 kW	Elektronika kompresora vonkajšia jednotka - 15/19 kW
20	TC142	Service valve - 6/9/12/15/19 kW	Service valve - 6/9/12/15/19 kW
21	TC169	Filter - 6/9/12/15/19 kW	Filter - 6/9/12/15/19 kW
22	TC134	Compressor crankcase heater - 15/19 kW	Ohrievač kompresora - 15/19 kW
23	TC135	Bottom plate heater - 15/19 kW	Drôťový ohrievač spodnej vaničky - 15/19 kW
24	TC136	PHE anti-free heater - 15/19 kW	Ohrievač doskového výmenníka - 15/19 kW
TC190		PHE anti-free heater - 15/19 kW	Ohrievač doskového výmenníka - 15/19 kW
25	TC137	Water inlet/outlet temp sensor - 19 kW	Snímač teploty prívodu/výstupu vody 19 kW
26	TC138	Indoor coil temp sensor (in PHE) - 15/19 kW	Snímač teploty výmenníka - 15/19 kW
27	TC139	Compressor discharge temp sensor - 15/19 kW	Snímač teploty výfuku kompresora - 15/19 kW
28	TC140	Compressor suction temp sensor - 15/19 kW	Snímač teploty sania kompresora - 15/19 kW
29	TC141	Ambient / outdoor coil temp sensors (twin) - 15/19 kW	Dvojité snímač vonkajšej teploty - 15/19 kW

TC115		SERIAL NUMBERS ONLY	
#	CODE		
1	TC155	Fan blower (Ø550x124) - 9/12/15/19 kW	Vrtuľa ventilátora (Ø550x124) - 9/12/15/19 kW
2	TC115	Fan motor - 6/9/12/15/19 kW	Motor ventilátora - 6/9/12/15/19 kW
3	TC165	Compressor - 15 kW	Kompresor - 15 kW
4	TC152	Gas storage tank - 15/19 kW	Zásobník plynu - 15/19 kW
5	TC107	Plate Heat Exchanger - 15 kW	Doskový výmenník tepla - 15 kW
6	TC129	4-way valve - 15/19 kW	Štvorcestý ventil - 15/19 kW
7	TC130	Coil of 4-way valve - 15/19 kW	Cievka štvorcestného ventilu - 15/19 kW
8	TC110	Water flow switch - 15/19 kW	Spínač prítoku - 15/19 kW
9	TC111	EEV - 15 kW	EEV - 15 kW
10	TC131	Coil of EEV - 15/19 kW	Cievka EEV - 15/19 kW
11	TC132	High pressure switch - 15/19 kW	Spínač vysokého tlaku - 15/19 kW
12	TC120	Low pressure sensor - 6/9/12/15/19 kW	Nízko tlakový snímač - 6/9/12/15/19 kW
13	TC119	High pressure sensor - 6/9/12/15/19 kW	Vysoko tlakový snímač - 6/9/12/15/19 kW
14	TC161	Evaporator coil - 15 kW	Výparník - 15 kW
15	TC122	Thermostat of PHE anti-free heater - 6/9/12/15/19 kW	Termostát protizamrazového systému - 6/9/12/15/19 kW
16	TC133	Transducer - 15/19 kW	Transformátor - 15/19 kW
TC200		Transducer - 15/19 kW	Transformátor - 15/19 kW
17	TC101	Outdoor controller - 15/19 kW	Riadiaca elektronika vonkajšia jednotka - 15/19 kW
18	TC102	Translating print board - 15/19 kW	Prevodník vonkajšia jednotka - 15/19 kW
19	TC159	Compressor Driver Board - 15/19 kW	Elektronika kompresora vonkajšia jednotka - 15/19 kW
20	TC142	Service valve - 6/9/12/15/19 kW	Service valve - 6/9/12/15/19 kW
21	TC169	Filter - 6/9/12/15/19 kW	Filter - 6/9/12/15/19 kW
22	TC134	Compressor crankcase heater - 15/19 kW	Ohrievač kompresora - 15/19 kW
23	TC135	Bottom plate heater - 15/19 kW	Drôťový ohrievač spodnej vaničky - 15/19 kW
24	TC136	PHE anti-free heater - 15/19 kW	Ohrievač doskového výmenníka - 15/19 kW
TC190		PHE anti-free heater - 15/19 kW	Ohrievač doskového výmenníka - 15/19 kW
25	TC187	Water inlet/outlet temp sensor - 15 kW	Snímač teploty prívodu/výstupu vody - 15 kW
26	TC138	Indoor coil temp sensor (in PHE) - 15/19 kW	Snímač teploty výmenníka - 15/19 kW
27	TC139	Compressor discharge temp sensor - 15/19 kW	Snímač teploty výfuku kompresora - 15/19 kW
28	TC140	Compressor suction temp sensor - 15/19 kW	Snímač teploty sania kompresora - 15/19 kW
29	TC141	Ambient / outdoor coil temp sensors (twin) - 15/19 kW	Dvojité snímač vonkajšej teploty - 15/19 kW

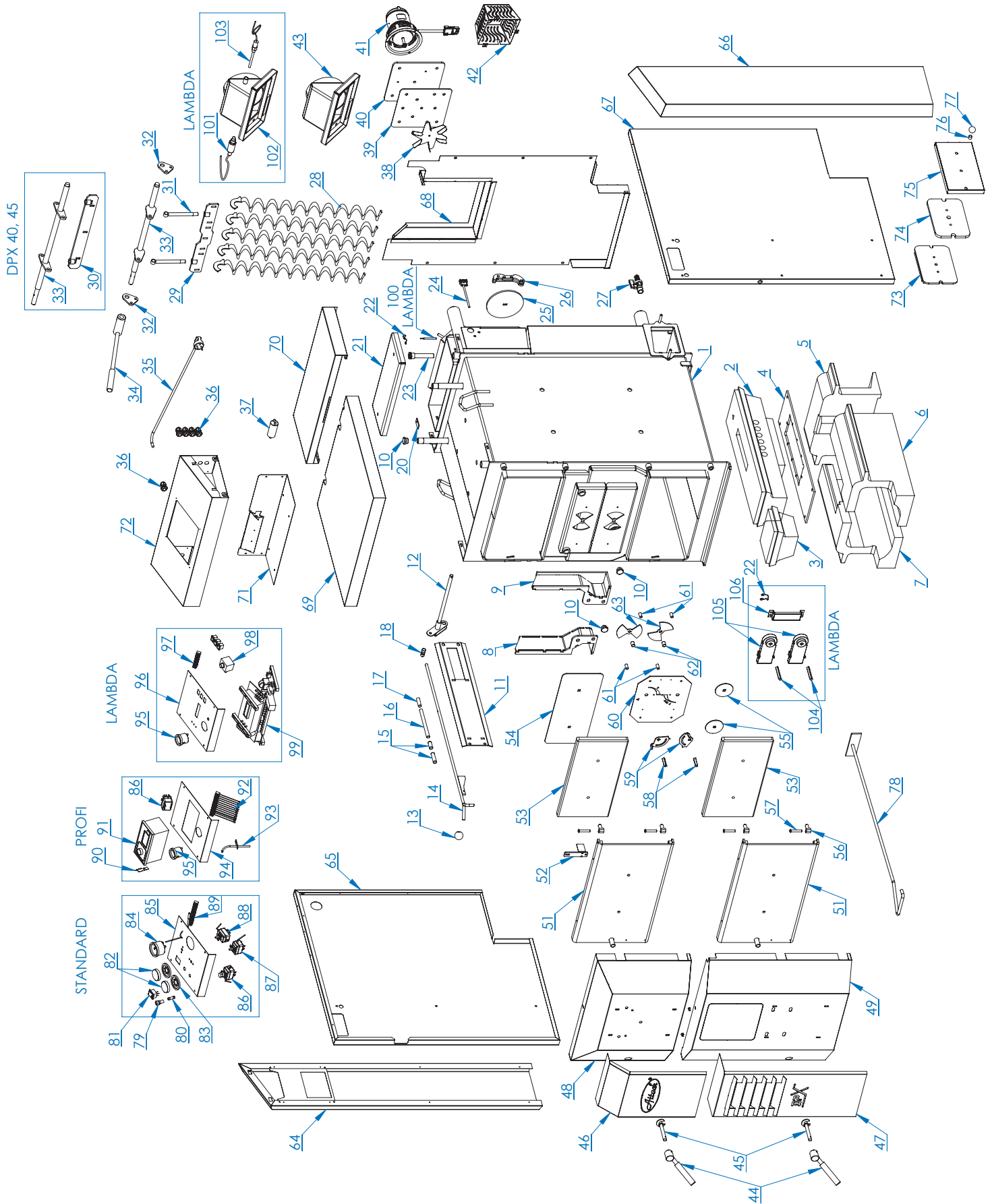



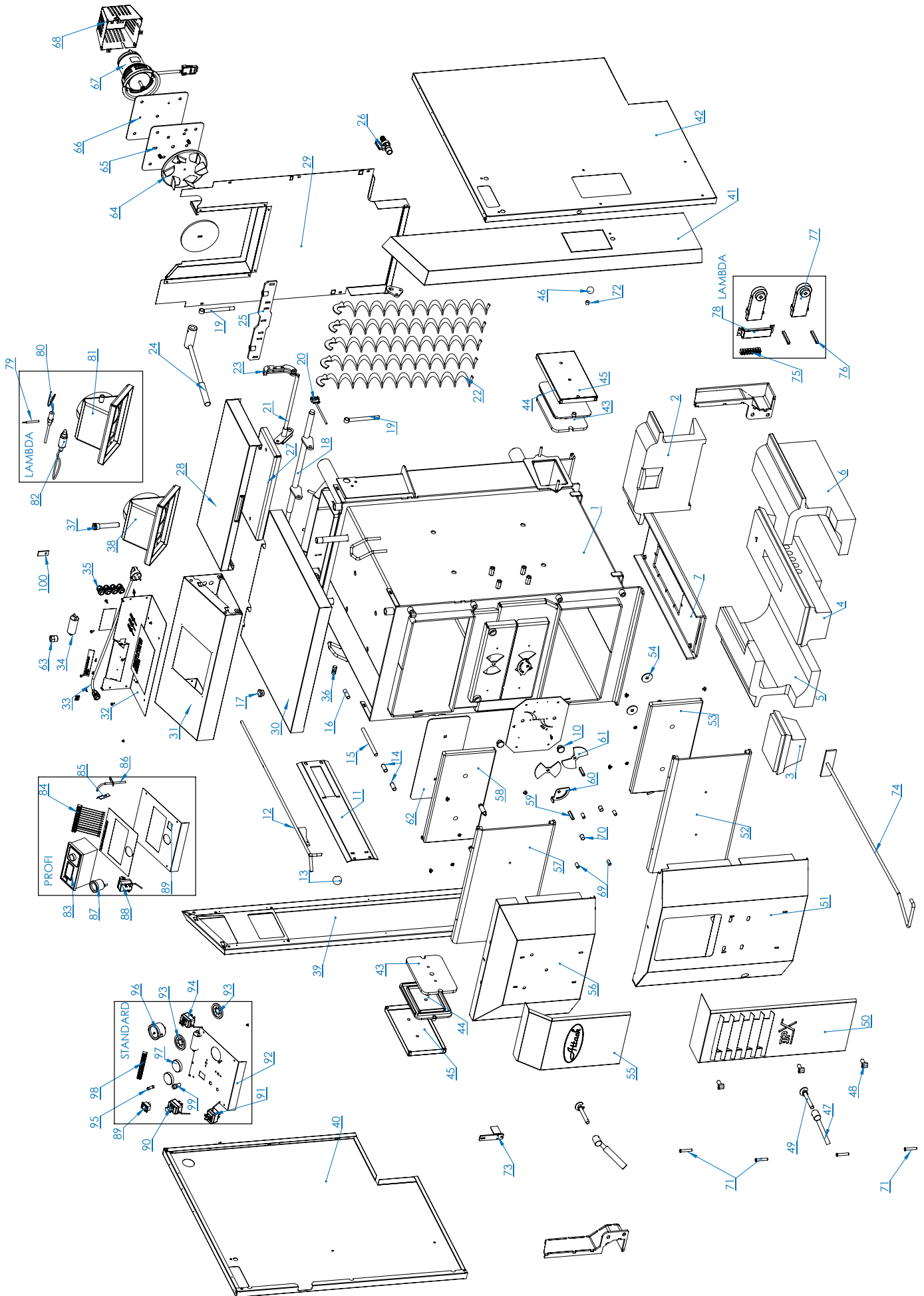

LAMBDA	
#	CODE
75	DPD15007B
76	DPV25301A
77	DPD25216
78	DPA15026
79	DPD25213
80	DPD25212A
81	DPV25925
82	DPD25214

PROFI	
#	CODE
83	DPD25073
84	DPD15030
85	DPD25034
86	DPD25059
87	AT46C
88	OT19C
89	TS095A
90	OT19C
91	DPD25008A
92	DPA15012
93	DPD25010
94	DPD25007B
95	TH06
96	TS099A
97	DPD25009
98	DPD15020
99	TH05A
100	DPD25061

#	CODE	
44	DPV25500A	
45	DPA15905A	
46	DPD25069	
47	DPD25420B	
48	PEL0490	
49	DPD25430	
50	DPA25911	
51	DPA25902	
52	DPV25095A	
53	DPD25030A	
54	DPV15086	
55	DPA25908	
56	DPA25901	
57	DPV25095A	
58	DPD25030A	
59	DPV25301	
60	DPV25329A	
61	DPV25203	
62	OT11	
63	DPV25360	
	DPD15011	15
	DPD25080	25
64	DPD45909B	30, 35
	DPD45909C	40, 45
65	DPD25001B	
	DPV25081	15, 25
66	DPV45040	30-45
	DPD25016D	15, 25
67	DPD25202D	30-45
	DPA45900	30-45
68	DPV25304	
69	DPV25303	
70	DPO25521A	
71	DPV25504A	
72	DPV25371A	
73	DPC25005A	
74		

#	CODE	
18	DPV15925	25-45
19	DPD25065	25-45
20	DPD25110	
21	DPV25366C	
22	DPV15930D	25-45
23	DPV25363B	
24	DPV15924A	25-45
25	DPV15921	25-45
26	TS103	
	PEL943	25-35
27	DPV45923	40,45
	DPA15010A	25-35
28	DPA45010A	40,45
29	DPA15903	15
	DPA15008A	25
30	DPA35008A	30,35
	DPA45008A	40,45
31	DPA15022A	
32	DPA15025	
33	TS091	
34	DPD25016A	
35	TS094A	
36	DPV25325A	
37	DPD25011	15
38	DPV25921B	25
39	DPA15901	30, 35
	DPA15001	40, 45
40	DPA25001	
	DPA35001	30, 35
	DPA45001	40, 45
41	DPA15907	
	DPA15002	15
42	DPA25002	25
	DPA35002	30, 35
	DPA45002	40,45
43	DPD15008A	

#	CODE	
	DP15500	15
1	DP25500	25
	DP35500	30,35
	DP45500	40,45
2	DPP35105	15,30,35
	DPP25104	25,40,45
3	DPT35004	30-45
	DPT15002	15
	DPT25004	25
4	DPT35005	30,35
	DPT45004	40,45
	DPP15103	15
5	DPP25105	25
	DPP35103	30, 35
	DPP45103	40, 45
	DPP15104	15
6	DPP25106	25
	DPP35104	30,35
	DPP45104	40, 45
	DPV15906	15
7	DPV25906	25
	DPV35906	30,35
	DPV45906	40,45
10	DPD25029	
	DPV15932	15
11	DPV25932C	25
	DPV35932A	30, 35
	DPV45932	40, 45
	DPD15901	15
12	DPD25901F	25
	DPD35901F	30, 35
	DPD45901	40, 45
13	DPD25021	
14	DPV25326	
15	DPV25331B	
16	DPV25327	
17	DPD25029	

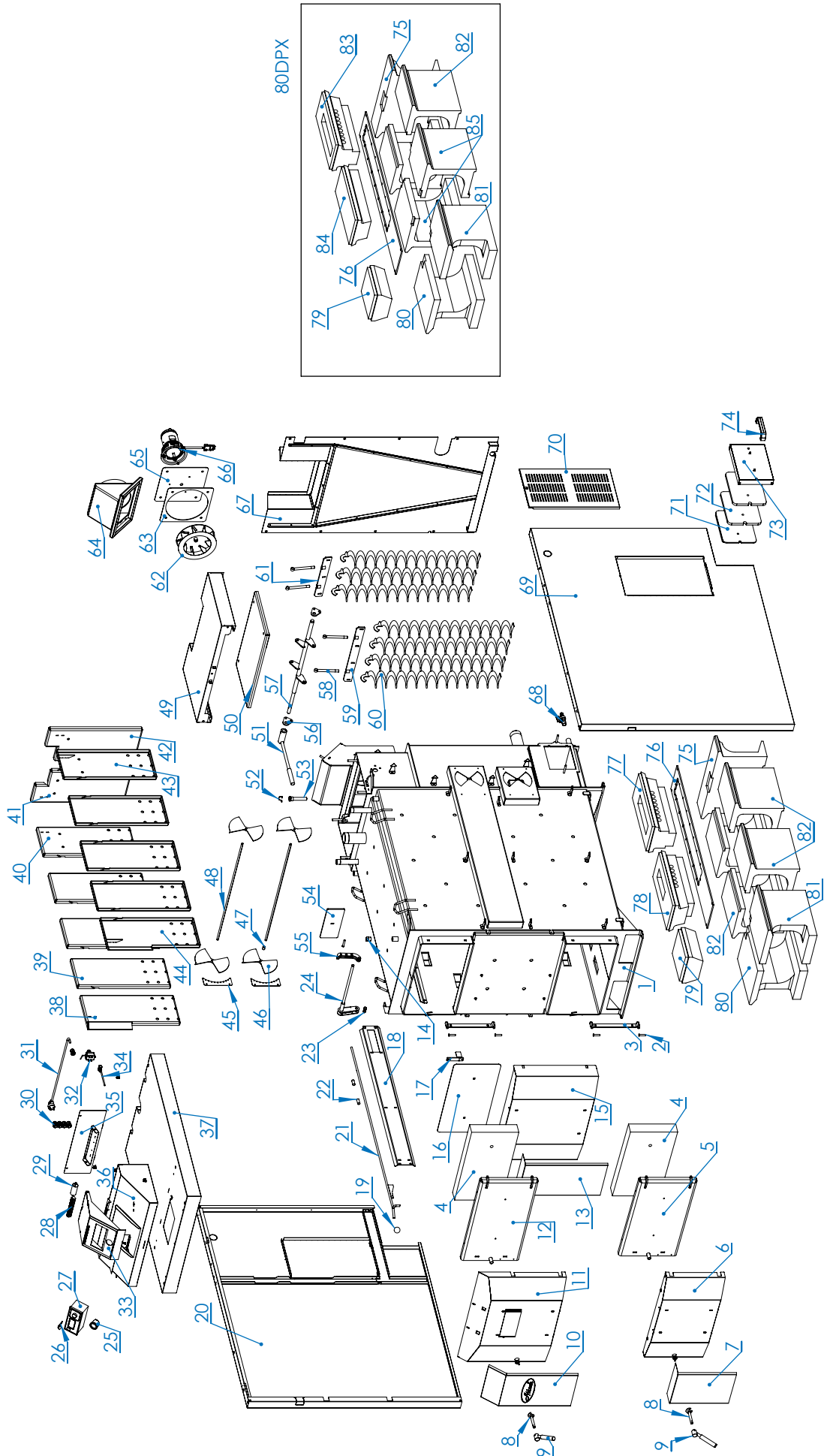

#	CODE
62	DPD75003
63	DPD75001A
64	DPV75911A
65	DPV75015
66	DPD75002
67	DPA80910
68	TS103
69	DPA80902
70	DPA80009
71	DPV75921A
72	DPV75288
73	DPV75925A
74	PEL801
75	DPP95108B
76	DPV80906
77	DPT75010
78	DPT10001
79	DPT75011
80	DPP95106B
81	DPP95105B
82	DPP95107B
83	DPT95005
84	DPT80001
85	DPP80001

#	CODE
32	OT19C
33	DPA80912
34	DPD75011
35	DPA80909
36	DPA80908
37	DPA80900
38	DPV75932
39	DPV75266
40	DPV75919
41	DPV75917
42	DPV75918
#	CODE
43	DPV75920
44	DPV75931
45	DPV80004
46	DPV75271
47	DPV25303
48	DPV75280
49	DPA80901
50	DPV75910A
51	DPV15924A
52	TS106
53	DPD25011
54	DPV75907
55	DPV75908A
56	DPV45035A
57	DPV75906A
58	DPD25065
59	DPV75904
60	DPV75905
61	DPV75930

#	CODE
1	DP80000
2	DPV25803
3	DPV75260
4	DPD75264
5	DPV75926
6	DPA80917
7	DPA80918
8	DPD25430
9	DPD25420B
10	DPA80913
11	DPA80914
12	DPV75926
13	DPA80916
14	OT11
15	DPA80915
16	DPV75047
17	DPV25371A
18	DPV75929
19	DPD25021
20	DPA80903
21	DPD75901
22	DPV25326
23	DPV25325A
24	DPV75922A
25	AT46C
26	DPD25034
27	DPD25073
28	DPD80001
29	DPD75002B
30	TS094A
31	ADF25544

#	CODE	#	CODE
1	DP25500	25	DPD15030
2	DP25500B*	25	DPD15016
3	DP35500	30,35	AT46C
4	DPD25613		
5	DPV25049	25	DPD25073
6	DPT35005	30,35	DPD25601C
7	DPT35004	30,35	DPO35601D
8	DPV25382D	25	DPO25813
9	DPV35382D	30,35	DPD25792
10	DPP25104	25	DPO35792
11	DPP25105	30,35	DPD15032D
12	DPP25106	25	DPD25603D
13	DPP35104	30,35	DPO35603D
14	DPP35103	30,35	DPO15009B
15	DPD25029		62 ADF25807
16	DPV25931C		63 ADF25223
17	DPV25930C		64 DPO25804
18	DPD25021		65 DPO25816
19	DPD25901F	25	66 DPV25818
20	DPD35901F	30,35	67 DPV25821
21	DPV25326		68 DPV25817
22	DPV25327		69 DPD25420
23	DPV25325A		70 DPD25430
24	DPV25366C		71 DPO25642
25	DPV25932C	25	72 DPO25800
26	DPV35932A	30,35	73 DPO25680
27	SP60		74 DPO25554
28	OT11		75 DPD25601
29	ADF2520A		76 DPV25095A
30	PEL943		77 DPV25371A
31	DPD25011		78 ADF25847
32	TS106		79 ADF25220A
33	DPD25110		80 DPV25803
34	DPV25360		81 PEL0490
35	TS103		82 DPO25521A
36	DPD25020	25	83 DPD25606
37	DPD25080*	25	84 DPD25030
38	DPD45909B	30,35	85 DPD25605A
39	DPD25001B		86 DPV95086
40	DPV25116	25	87 DPV25301
41	DPV25081*	25	88 DPV25329A
42	DPV45040	30,35	89 DPV35711
43	DPD25016D	25	90 DPV25304
44	DPD25202D	30,35	91 DPV25303
45	DPD45005		92 DPV25203
46	DPV25921B		93 DPV25500
47	DPV15930D		94 DPD15008A
48	DPV15921		95 DPO15006D
49	DPD25065		96 DPV25504
50	DPV45035A		97 DPV25021
51	DPV15925		98 DPC25005A
52	DPV15924A		99 DPD25646
53	TS091		100 DPO25808
54	TS094A		101 DPD25632
55	OT19C		102 DPD25634
56	DPD25016A	25	103 DPD25631
57	DPD45003	30,35	104 DPD25624
58	DPD15900		105 DPD25627
59	DPO15014		106 DPD25629
			107 DPD25621
			108 DPD25614
			109 DPD25626
			110 PELH30ACP

\*11/2016 -

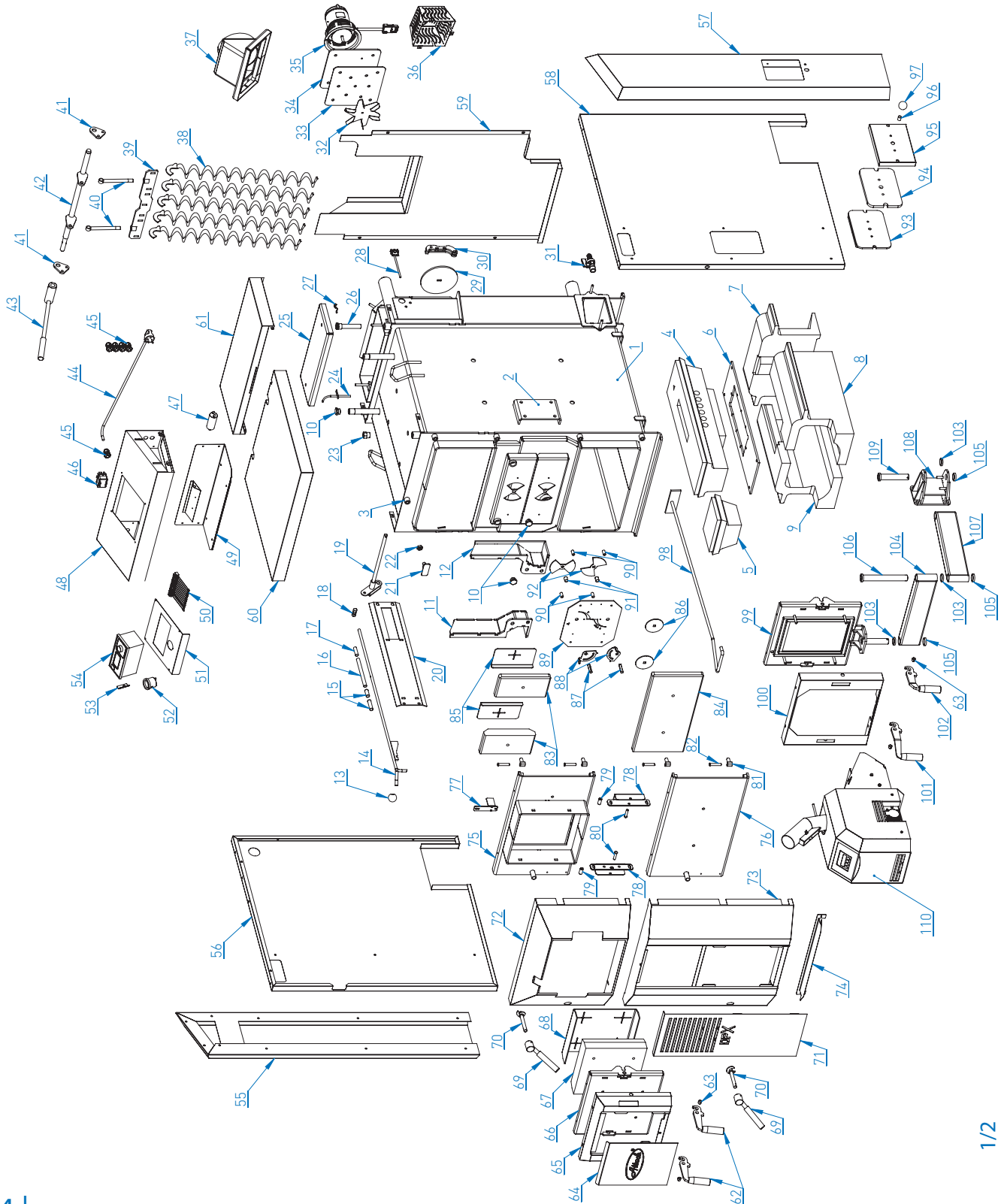

#	CODE
115	PELH30900A
116	H30921C
117	H30920B
118	H30940A
119	H30001
120	H30930A
121	H30009A
122	PR15
123	H30982
124	H30952
125	H30012A
126	H30961B
127	PELH30851
128	PELH30800A
129	TS215
130	PELH30807B
131	H30020
132	H30809
133	H30820
134	H30970A
135	H30808
136	H30806B
137	H30951B
138	H30807
139	H30122
140	H30014
141	H30804
142	H30803
143	H30003A
144	H30002
145	TH31
146	H30021
147	TH23A
148	H30980
149	ADF25640
150	PELH30830A
151	H30701C
152	H30008
153	H30813A

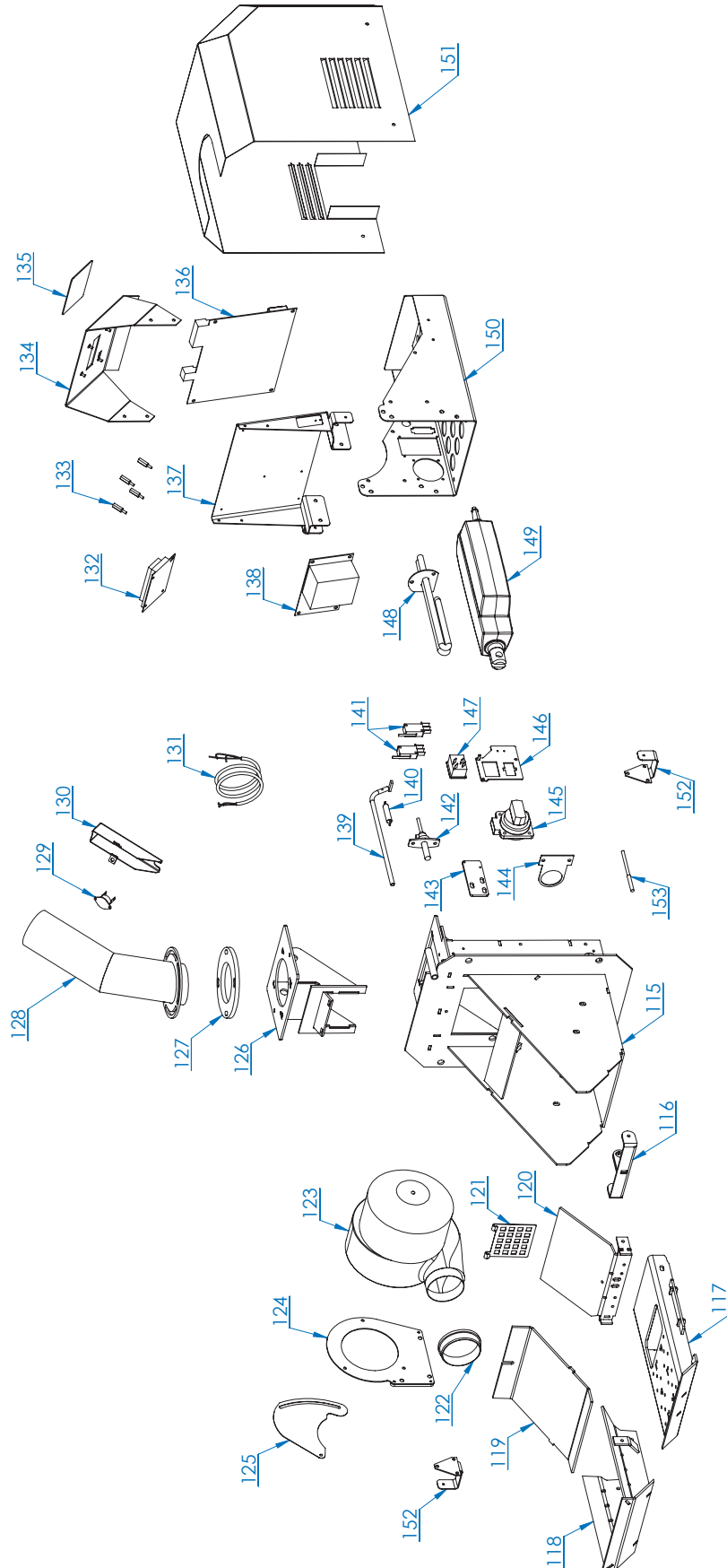

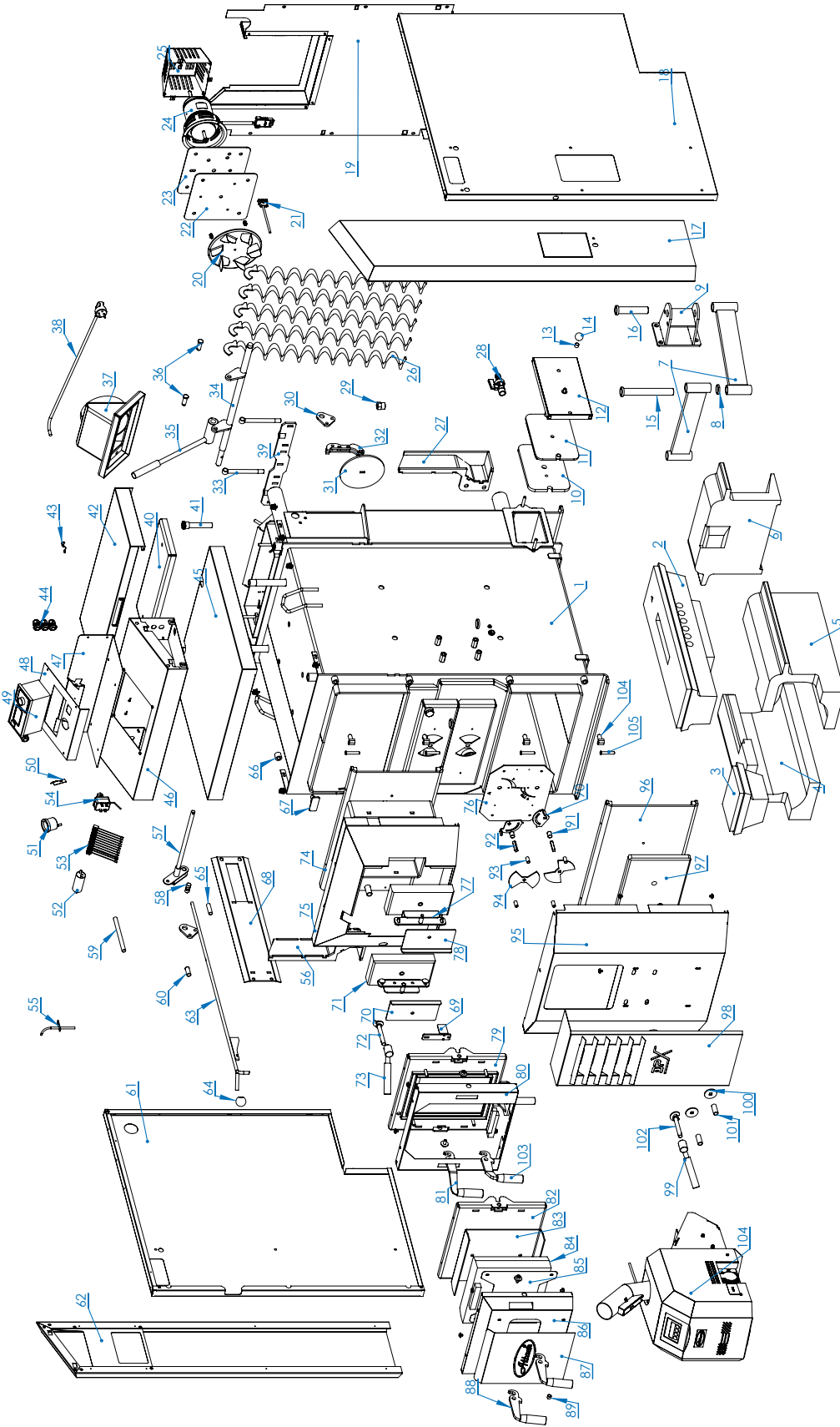

ATTACK DXCP 25,30,35,40,45,50  
5/2019

#	CODE	#	CODE
90	DPV25329A	73	DPD25420B
91	DPV25303	74	DPD25601
92	DPV25301	75	DPA25905
93	DPV25304	76	DPV35711
94	DPV25203	77	ADF25840
95	DPA25902	78	DPD25605A
96	DPV25095A	79	DPD25646
97	DPD25030A	80	DPA25917
98	DPA25910	81	DPA25918
99	DPD25420B	82	DPD25632
100	DPV15086	83	DPV25818
101	DPV15087	84	DPV25817
102	DPD25430	85	DPV25827
103	DPD25634	86	DPV25932C
104	PELH30ACP	87	DPA25914
	PELH50ACP	88	ADF25807
		89	ADF25223

#	CODE	#	CODE
56	DPV25931C	61	DPA25001
57	DPV25366C	62	DPA15901
58	DPV25325A	63	DPD25901F
59	DPV25331B	64	DPD25021
60	DPV25326	65	DPV25327
		66	DPV25049
		67	DPV25827
		68	DPV25932C
		69	DPV25371A
		70	DPD25605A
		71	DPD25606
		72	DPD25430

#	CODE	#	CODE
40	DPV45923	45	DPA35008A
41	DPD25011	46	DPA15904
42	DPA15010A	47	DPA15025
43	DPA45010A	48	DPA15014
44	TS106	49	DPD25073
		50	DPD25034
		51	AT46C
		52	DPD25016A
		53	DPD15030
		54	OTT19C
		55	DPD25059

#	CODE	#	CODE
24	DPD25016D	29	OTT11
25	DPD25020D	30	DPV45035A
26	DPA45900	31	DPV25360
27	DPV15930D	32	DPV25363B
28	DPV25930C	33	DPD25065
		34	DPV15925
		35	DPV15928
		36	SP146
		37	DPV25921B
		38	TS091
		39	DPV15921
		40	PEL943

#	CODE	#	CODE
11	DPV25500A	16	DPD25626
12	DPA15905A	17	DPA15907
13	DPV25504A	18	DPA35002
14	DPD25069	19	DPA45002
15	DPD25629	20	DPD25080
16	DPD25626	21	DPD45909B
17	DPA15907	22	DPD25110
18	DPA35002	23	DPD45120
19	DPA45002		DPV25081
20	DPD25080		DPV45040
21	DPD45909B		
22	DPD25110		
23	DPD45120		

#	CODE	#	CODE
25	DPV25500B	25	DPV25500B
30,35	DP35500	30,35	DP35500
40-50	DPA45500	40-50	DPA45500
20	DPT25004	20	DPT25004
30,35	DPT35005	30,35	DPT35005
40-50	DPT45004	40-50	DPT45004
30-50	DPT25103	30-50	DPT25103
25	DPD25105	25	DPD25105
40-50	DPP45103	40-50	DPP45103
25	DPP25106	25	DPP25106
30,35	DPP35104	30,35	DPP35104
40-50	DPP45104	40-50	DPP45104
25-35	DPD25104	25-35	DPD25104
30,35	DPP35105	30,35	DPP35105
	ADF25911		ADF25911
	DPD25905		DPD25905
	DPD15008A		DPD15008A

#	CODE	#	CODE
25	DPV25500B	25	DPV25500B
30,35	DP35500	30,35	DP35500
40-50	DPA45500	40-50	DPA45500
20	DPT25004	20	DPT25004
30,35	DPT35005	30,35	DPT35005
40-50	DPT45004	40-50	DPT45004
30-50	DPT25103	30-50	DPT25103
25	DPD25105	25	DPD25105
40-50	DPP45103	40-50	DPP45103
25	DPP25106	25	DPP25106
30,35	DPP35104	30,35	DPP35104
40-50	DPP45104	40-50	DPP45104
25-35	DPD25104	25-35	DPD25104
30,35	DPP35105	30,35	DPP35105
	ADF25911		ADF25911
	DPD25905		DPD25905
	DPD15008A		DPD15008A

# ATTACK DPX COMBI PELLET 25, 30, 35

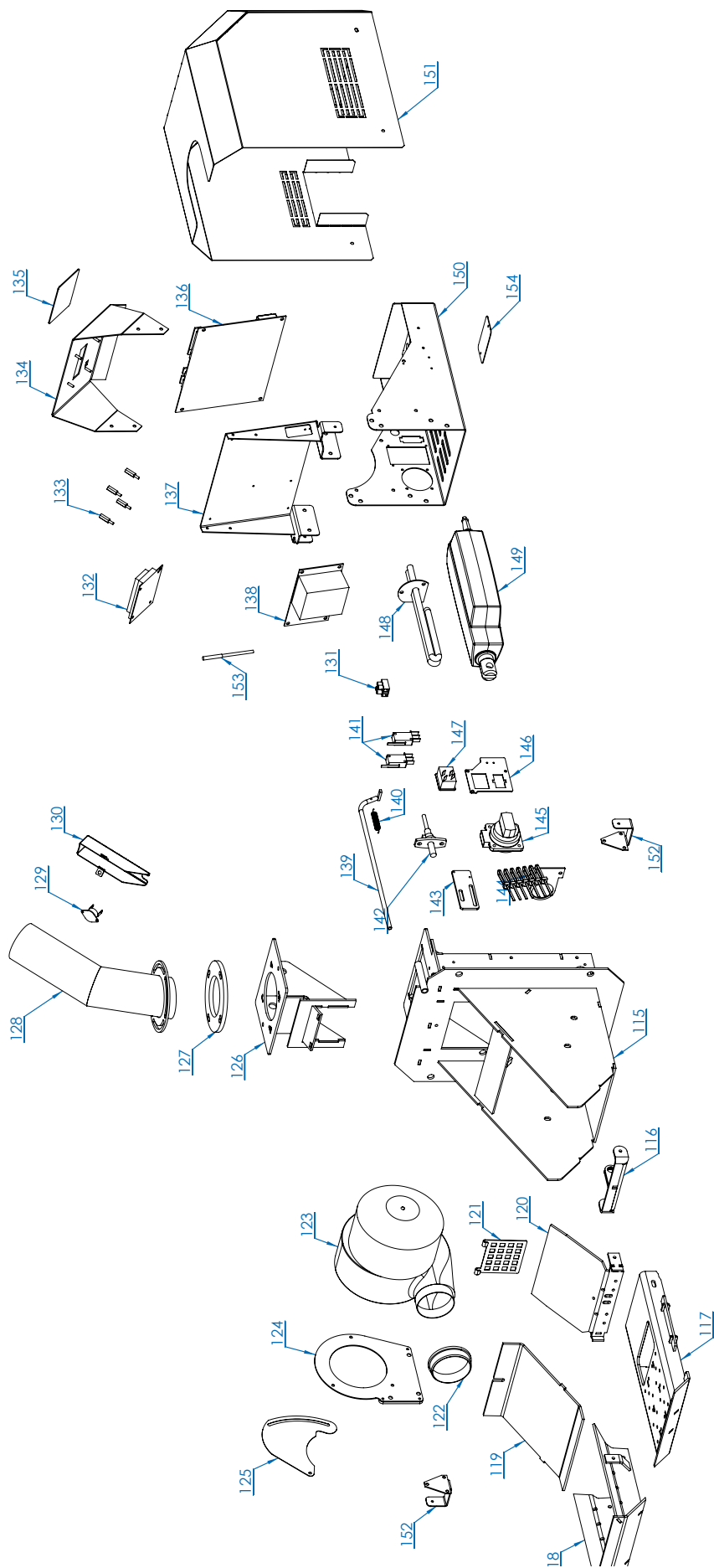

#	CODE
151	H30701C
152	H30008
153	H30813A
154	PELH30811

#	CODE
139	H30122
140	H30014
141	H30804
142	H30803
143	H30003A
144	H30002
145	TH31
146	H30021
147	TH23A
148	H30980
149	ADF25640
150	PELH30830A

#	CODE
127	PELH30851
128	PELH30800A
129	T5215
130	PELH30807B
131	H30020
132	H30809
133	H30820
134	H30970A
135	H30808
136	H30806B
137	H30951B
138	H30807

#	CODE
115	PELH30900A
116	H30921C
117	H30920B
118	H30940A
119	H30001
120	H30930A
121	H30009A
122	PR15
123	H30982
124	H30952
125	H30012A
126	H30961B

#	CODE	#	CODE
1	DP45500	57	DPO45601C
2	DPD25613	58	DPO25813
3	DPV25049	59	DPO45792
4	DPT45004	60	DPO15032D
5	DPT35004	61	DPO45603C
6	DPV45382D	62	DPO45009B
7	DP25104	63	ADF25807
8	DDP45104	64	ADF25223
9	DDP45103	65	DPO25804
10	DPD25029	66	DPO25816
11	DPV25931C	67	DPV25818
12	DPV25930C	68	DPV25821
13	DPD25021	69	DPV25817
14	DPD45901	70	DPD25420B
15	DPV25326	71	DPD25430
16	DPV25331B	72	DPO25642
17	DPV25327	73	DPO25800
18	DPV25325A	74	DPO25680
19	DPV25366C	75	DPO25554
20	DPV45932	76	DPD25601
21	DPV25827	77	DPV25095A
22	SP60	78	DPV25371A
23	OT11	79	ADF25847
24	DPD25059	80	ADF25220A
25	DPV45923	81	DPV25803
26	DPD25011	82	PEL0490
27	TS106	83	DPQ25521A
28	DPD45120	84	DPD25606
29	DPV25360	85	DPD25030
30	DPV25363B	86	DPD25605A
31	TS103	87	DPV95086
32	DPD45909C	88	DPV25301
33	DPD25001B	89	DPV25329A
34	DPV45040	90	DPV35711
35	DPD25202D	91	DPV25304
36	DPD45005	92	DPV25303
37	DPV25921B	93	DPV25203
38	DPV15930D	94	DPV25500
39	DPV15923	95	DPD15008A
40	DPV15921	96	DPO15006D
41	DPD25065	97	DPV25504
42	DPV45035A	98	DPD25021
43	DPV15928	99	DPC25005A
44	DPV15924A	100	DPD25636
45	TS091	101	DPO25807A
46	TS094A	102	DPD25632
47	OT19C	103	DPD25634
48	DPD45003	104	DPD25631
49	DPO15900	105	DPD25624
50	DPO15014	106	DPD25627
51	DPD15030	107	DPD25629
52	DPO15016	108	DPD25621
53	AT46C	109	DPD25614
54	DPD25034	110	DPD25626
55	DPD25073	111	PELH50ACP
56	DPO15027B		

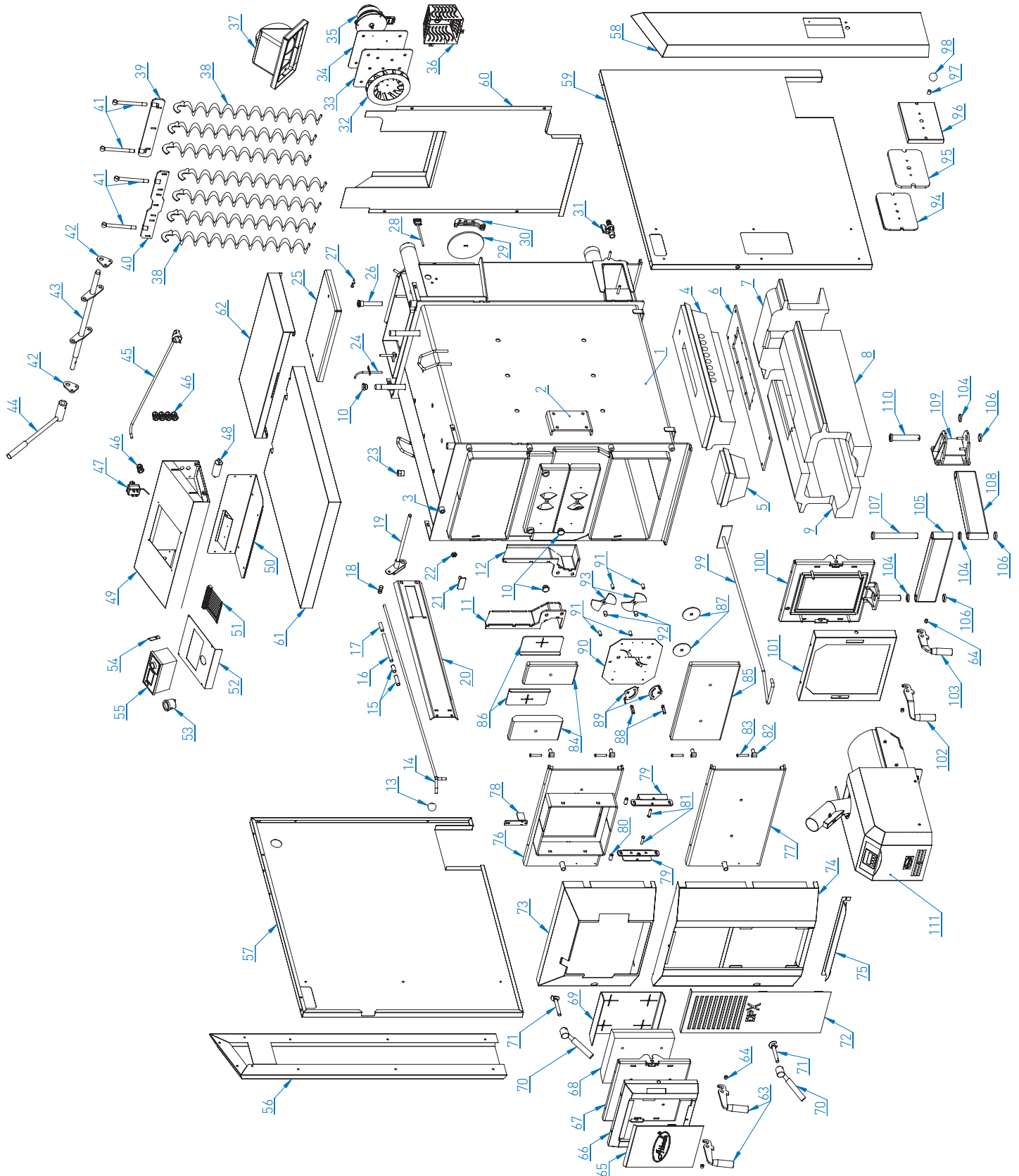

# ATTACK DPX COMBI PELLET 40, 45, 50

#	CODE
115	PELH50907A
116	PELH50906
117	PELH50901
118	PELH50905A
119	PELH50904A
120	PELH50044A
121	PELH50045
122	PELH50909
123	PELH30800A
124	PELH30851
125	TS215
126	PELH30807B
127	PELH50912
128	PELH50049
129	PEL937
130	PELH50068
131	H30809
132	H30820
133	PELH50911
134	H30808
135	H30806B
136	PELH50910
137	PELH50058
138	PELH50913
139	PELH50914
140	H30014
141	H30804
142	DPD45003
143	H30803
144	PELH50077
145	PELH50047
146	PELH50056A
147	PELH50051
148	PELH50052
149	PELH50055
150	PELH50076
151	PELH50054
152	PELH50066
153	H30980A
154	H30813A
155	PELH50050A
156	PELH50053
157	PELH50046B
158	PELH50081
159	PELH50064
160	TH31
161	TH23A
162	TH05A
163	TH06B
164	TS118L
165	PELH50040A

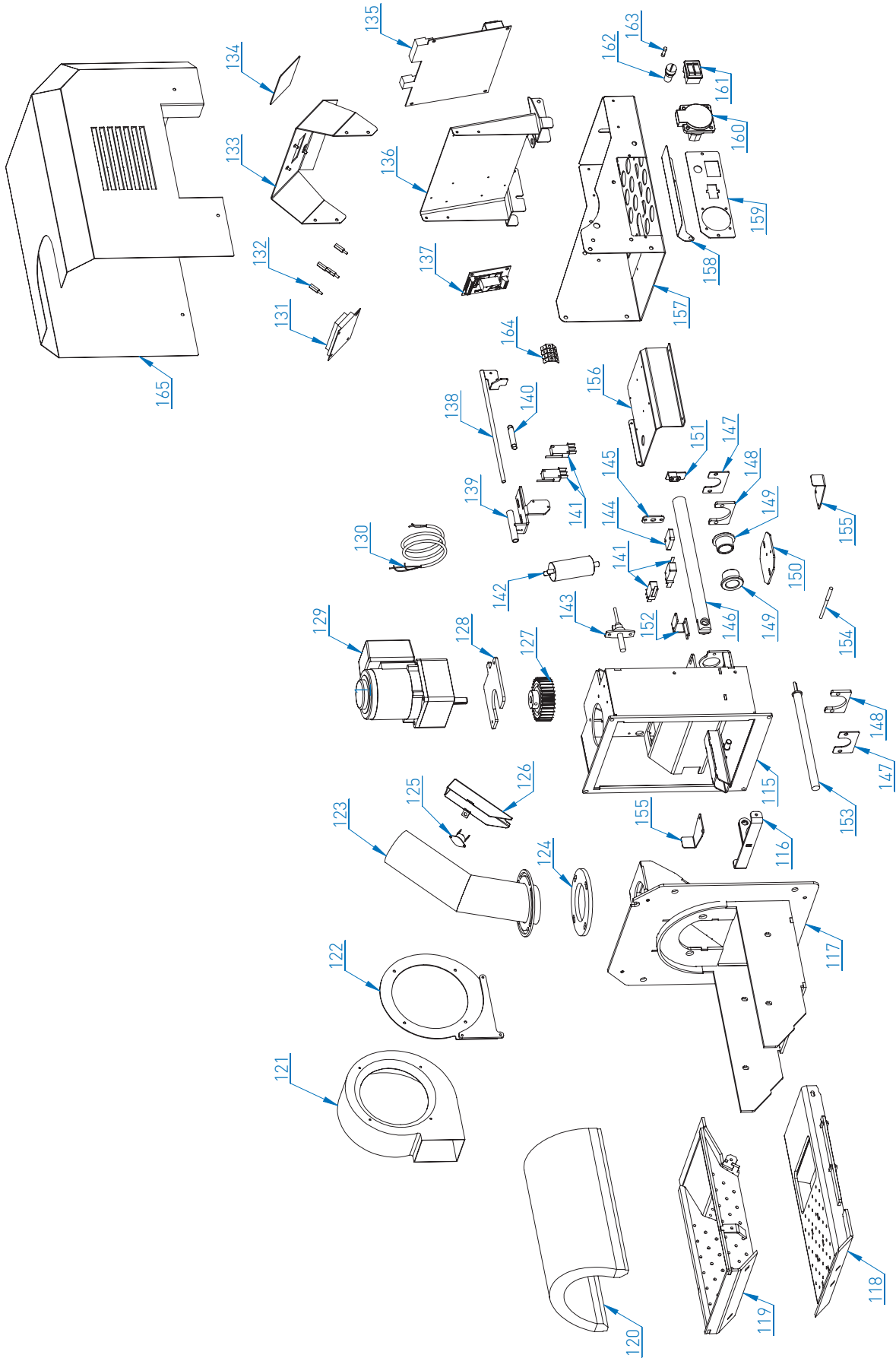

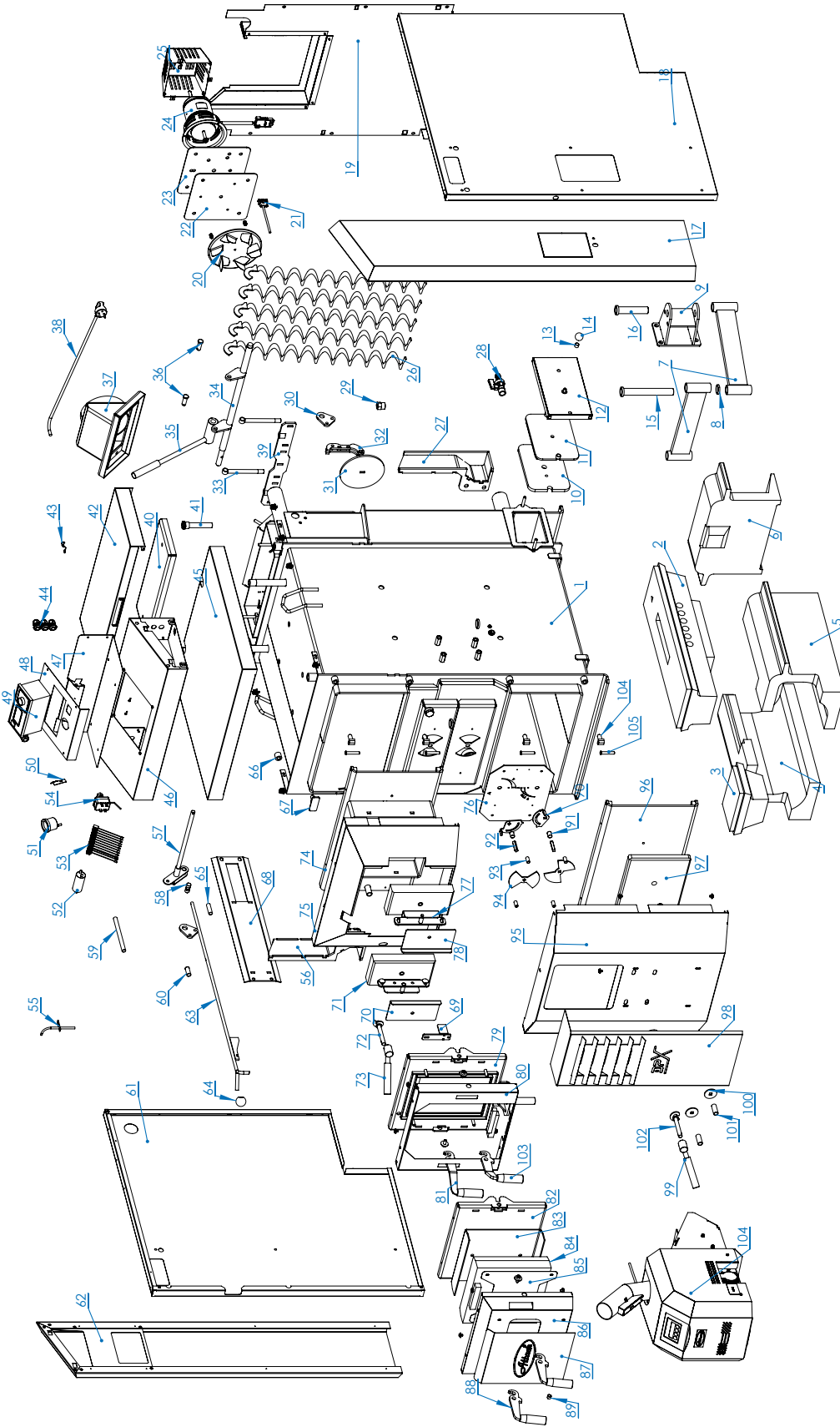

#	CODE	#	CODE
90	DPV25329A	99	DPD25420B
91	DPV25303	100	DPV15086
92	DPV25301	101	DPV15087
93	DPV25304	102	DPD25430
94	DPV25203	103	DPD25634
95	DPA25902	104	PELH30ACP
96	DPV25095A		PELH50ACP
97	DPD25030A		40-50
98	DPA25910		25-35
99	DPD25420B		40-50

#	CODE	#	CODE
73	DPD25420B	78	DPD25605A
74	DPD25601	79	DPD25636
75	DPA25905	80	DPA25918
76	DPV35711	81	DPD25632
77	ADF25840	82	DPV25818
78	DPD25605A	83	DPV25817
79	DPD25636	84	DPV25827
80	DPA25918	85	DPA25030
81	DPD25632	86	DPA25049
82	DPV25818	87	DPA25914
83	DPV25817	88	ADF25807
84	DPV25827	89	ADF25223
85	DPA25030		
86	DPA25049		
87	DPA25914		
88	ADF25807		
89	ADF25223		

#	CODE	#	CODE
56	DPV25931C	61	DPA35001
57	DPV25366C	62	DPA15901
58	DPV25325A	63	DPD25901F
59	DPV25331B	64	DPD25021
60	DPV25326	65	DPV25327
		66	DPV25049
		67	DPV25827
		68	DPV25932C
		69	DPV25371A
		70	DPD25605A
		71	DPD25606
		72	DPD25430

#	CODE	#	CODE
40	DPV45923	45	DPA35008A
41	DPD25011	46	DPA15904
42	DPA15010A	47	DPA15025
43	DPA45010A	48	DPA15014
44	TS106	49	DPD25073
45	TS094A	50	DPD25034
46	DPA35008A	51	AT46C
47	DPA15904	52	DPD25016A
48	DPA15014	53	DPD15030
49	DPD25073	54	OTT19C
50	DPD25034	55	DPD25059
51	AT46C		
52	DPD25016A		
53	DPD15030		
54	OTT19C		
55	DPD25059		

#	CODE	#	CODE
24	DPD25016D	25	
25	DPD25020D	26	
26	DPA45900	27	
27	DPV15930D	28	
28	DPV25930C	29	
29	TS103	30	
30	DPV45035A	31	
31	DPV25360	32	
32	DPV25363B	33	
33	DPD25065	34	
34	DPV15925	35	
35	DPV15928	36	
36	DPV15924A	37	
37	SP146	38	
38	DPV25921B	39	
39	TS091	40	
40	PEL943		

#	CODE	#	CODE
11	DPV25500A	16	DPD25626
12	DPA15905A	17	DPA15907
13	DPV25504A	18	DPA35002
14	DPD25069	19	DPA45002
15	DPD25629	20	DPA15903
16	DPD25626	21	DPD25080
17	DPA15907	22	DPD45909B
18	DPA35002	23	DPD25110
19	DPA45002	24	DPD45120
20	DPA15903	25	DPV25081
21	DPD25080		
22	DPD45909B		
23	DPD25110		
24	DPD45120		
25	DPV25081		

#	CODE	#	CODE
25	DP25500B	30	
26	DP35500	31	
27	DPA45500	32	
28	DPT25004	33	
29	DPT35005	34	
30	DPT45004	35	
31	DPT25104	36	
32	DPT35105	37	
33	DPT45103	38	
34	DPP35103	39	
35	DPP35106	40	
36	DPP35104		
37	DPP45104		
38	DPD25104		
39	DPP35105		
40	ADP25911		
41	DPD25905		
42	DPD15008A		

# ATTACK DPX COMBI PELLET 40, 45, 50

9	PELH50918
10	PELH50090
11	PELH30811
12	PELH50064A
13	TH31
14	TH23A
15	TH05A
16	TH06B
17	H30813A
18	PELH50915
19	PELH50081
20	DPD75002B
21	H30806B
22	PELH50910A
23	H30807
24	H30808
25	PELH50911
26	PELH50040A
27	PELH50068
28	H30809
29	H30820
30	H30980
31	PELH50913
32	H30818
33	H30014
34	PELH50914
35	H30803
36	PELH30807B
37	TS215B
38	PELH30800A
39	PELH30851
40	PELH50909
41	PELH50045

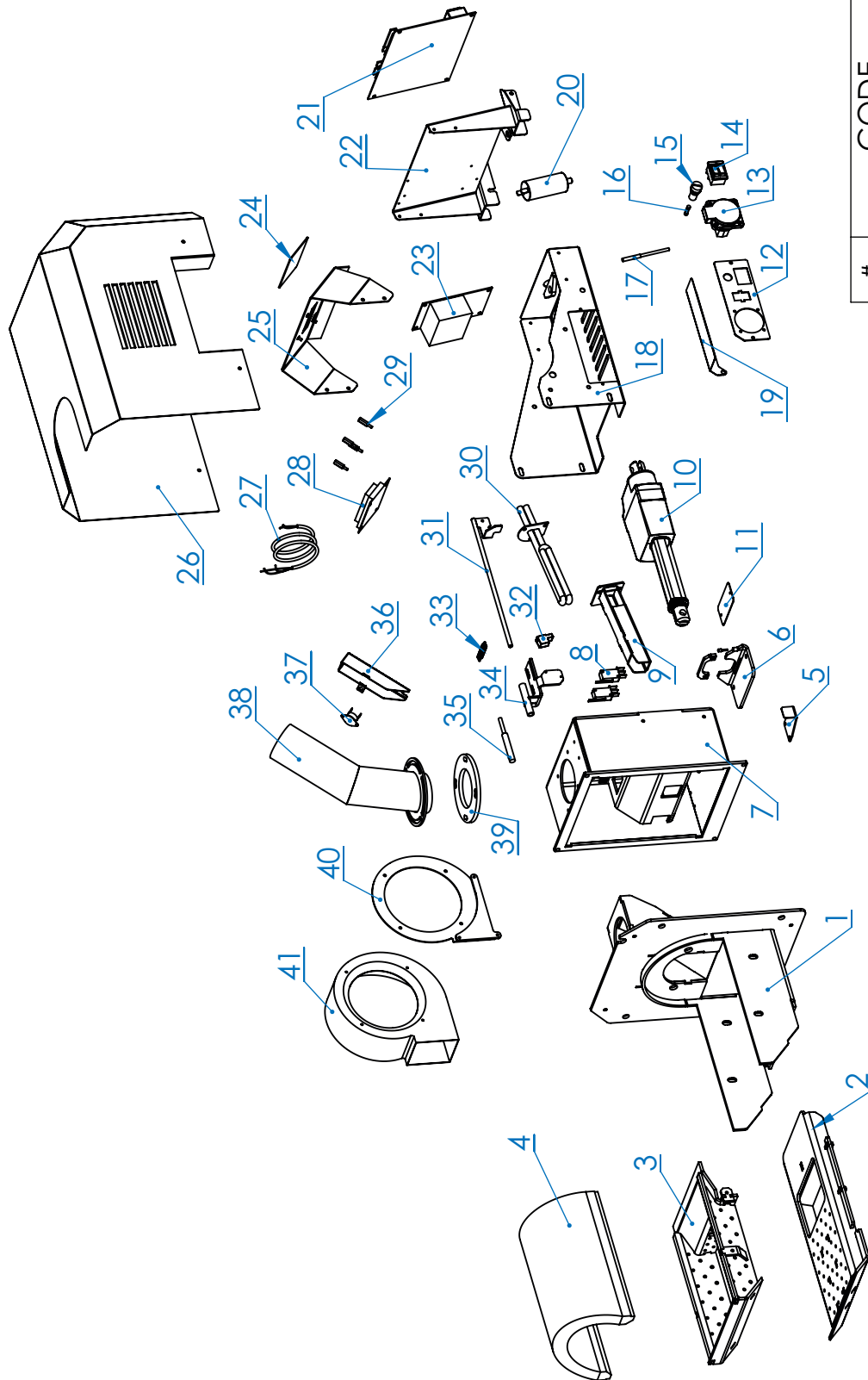

#	CODE
1	PELH50901A
2	PELH50905C
3	PELH50904B
4	PELH50044B
5	PELH50050A
6	PELH50082
7	PELH50907B
8	H30804

#	CODE	#	CODE
1	AT46C	36	DP015006D
2	SL20935A	37	SL20036C
3	SL20102	38	SL20929A
4	DPD25073	39	SL20931
5	OT19C	40	SL20928A
6	SL20096A	41	SL20927A
7	SL20936A	42	SL20932
8	DPD25016A	43	SL20097A
9	SL20914A	44	SL20111A
10	SL20022A	45	SL20926A
11	SL20913A	46	DPD25030
12	SL20912A	47	SL20121
13	SL20915A	48	SL20033
14	DP015009B	49	SL20098A
15	SL20122A	50	DPV25095A
16	SL20911	51	SL20123
17	SL20040	52	DPV95086
18	SL20041	53	DPD25420B
19	DPD25059	54	DPD25430
20	SL20937	55	SP111
21		56	DPV25303
22	DPD25080	57	SL20068
23	DPD25001B	58	DK418
24	DPV25081	59	SL20066
25	DPD25016D	60	SL20067
26	DPV15925	61	DPT35004
27	DPV15924A	62	DPT20001
28	DPV45035A	63	DPP35103
29	DPD25065	64	DPP35104
30	DPV15921	65	DPP35105
31	SL20924	66	DPD25011
32	SL20916A	67	DPD25110
33	SL20034C	68	SL20901
34	DPV25500	69	DPC25005A
35	DPD15008A	70	

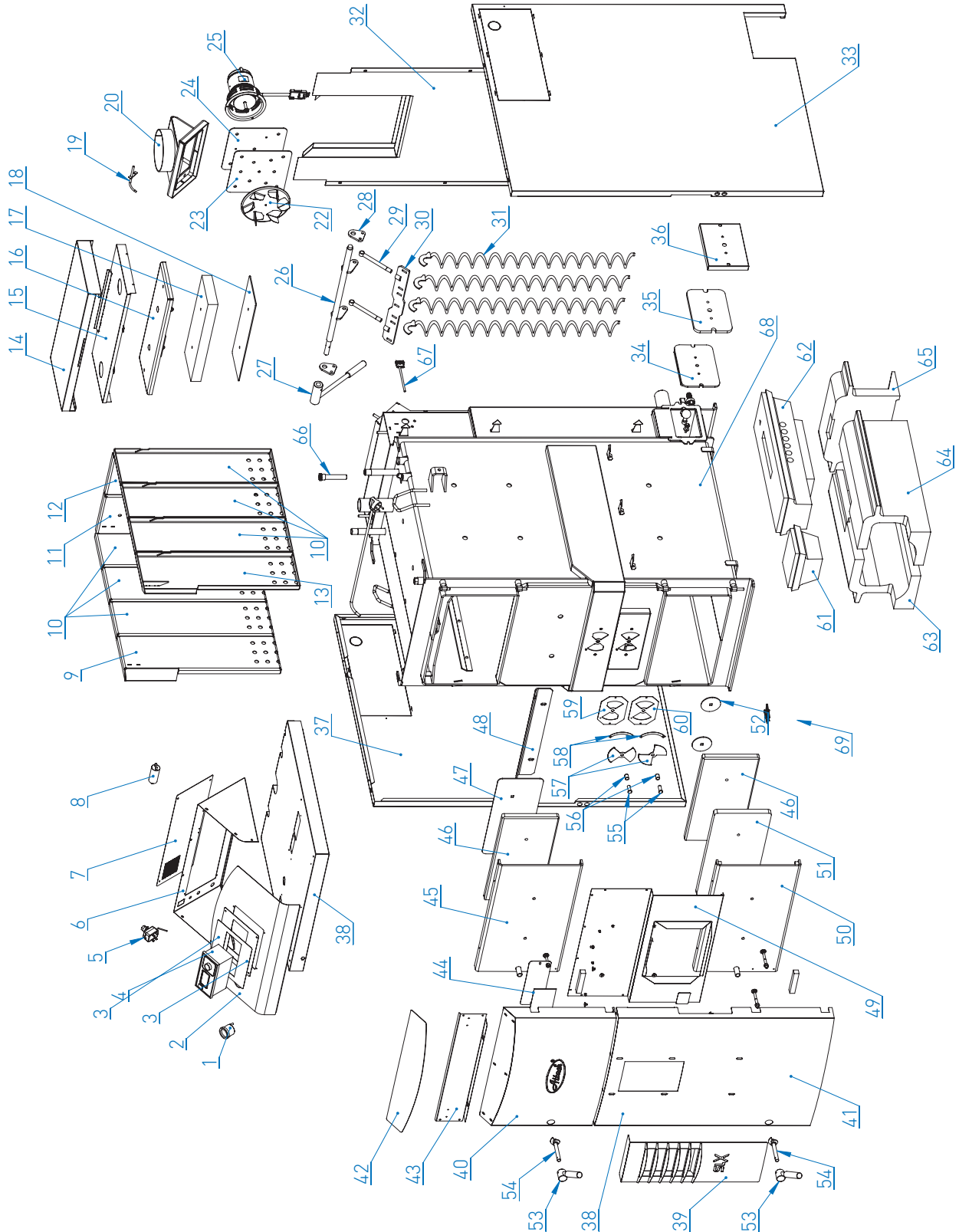

#	CODE	#	CODE
1	AT46C	43	SL20036C
2	SL20935A	44	SL20929A
3	DPD25221	45	DPD15016A
4	SL20092	46	DPD25220
5	SL20096A	47	SL20107
6	TS095A	48	SL20108
7	OT19C	49	ADF25478
8	SL20119A	50	SL20932
9	SL20120	51	SL20931
10	SL20914A	52	SL20928A
11	SL20022A	53	SL20111A
12	SL20913A	54	SL20097A
13	SL20912A	55	SL20124
14	SL20915A	56	SL20926A
15	DPO15009B	57	DPD25030
16	SL20122A	58	SL20121
17	SL20911	59	SL20033
18	SL20040	60	SL20927A
19	SL20041	61	SL20098A
20	DPD25059	62	DPV25095A
21	ADF25816	63	SL20123
22	DPD25223	64	DPD25030
23		65	DPV95086
24	DPD25080	66	DPD25420B
25	DPD25001B	67	DPD25430
26	DPV25081	68	DPD25216
27	DPD25016D	69	SL20032
28	DPV15925	70	DPV25203
29	DPV45035A	71	SL20118A
30	SL20919B	72	SL20095A
31	DPD25065	73	SL20129
32	DPV15921	74	DPT35004
33	SL20924	75	DPT20001
34	SL20130	76	DPP35103
35	SL20128A	77	DPP35104
36	H30810	78	DPP35105
37	SL20916A	79	DPD25011
38	SL20055B	80	ADF25602
39	SL20034C	81	DPD25110
40	DPO15006D	82	SL20901
41	DPD15008A	83	DPC25005A
42	DPV25500		

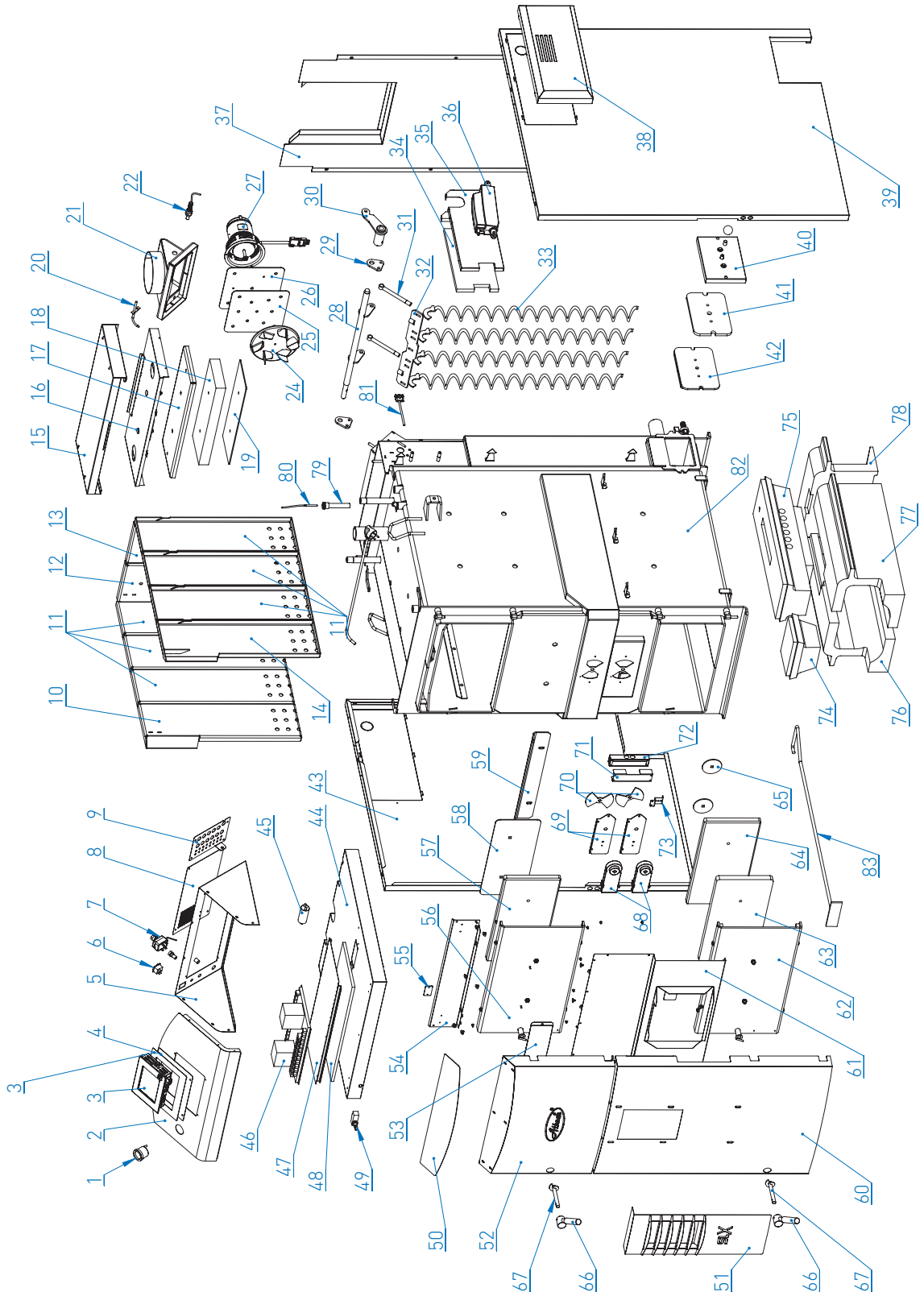

#	CODE	#	CODE
1	AT46C	36	DP015006D
2	SL20935A	37	SL20036C
3	SL20102	38	SL20929A
4	DPD25073	39	SL20931
5	OT19C	40	SL20928A
6	SL20096A	41	SL20927A
7	SL20936A	42	SL20932
8	DPD25016A	43	SL20097A
9	SL20914A	44	SL20111A
10	SL20022A	45	SL20926A
11	SL20913A	46	DPD25030
12	SL20912A	47	SL20121
13	SL20915A	48	SL20033
14	DP015009B	49	SL20098A
15	SL20122A	50	DPV25095A
16	SL20911	51	SL20123
17	SL20040	52	DPV95086
18	SL20041	53	DPD25420B
19	DPD25059	54	DPD25430
20	SL20937	55	SP111
21		56	DPV25303
22	DPD25080	57	SL20068
23	DPD25001B	58	DK418
24	DPV25081	59	SL20066
25	DPD25016D	60	SL20067
26	DPV15925	61	DPT35004
27	DPV15924A	62	DPT20001
28	DPV45035A	63	DPP35103
29	DPD25065	64	DPP35104
30	DPV15921	65	DPP35105
31	ADF25921	66	DPD25011
32	SL20916A	67	DPD25110
33	SL20034C	68	SL20901
34	DPV25500	69	DPC25005A
35	DPD15008A	70	

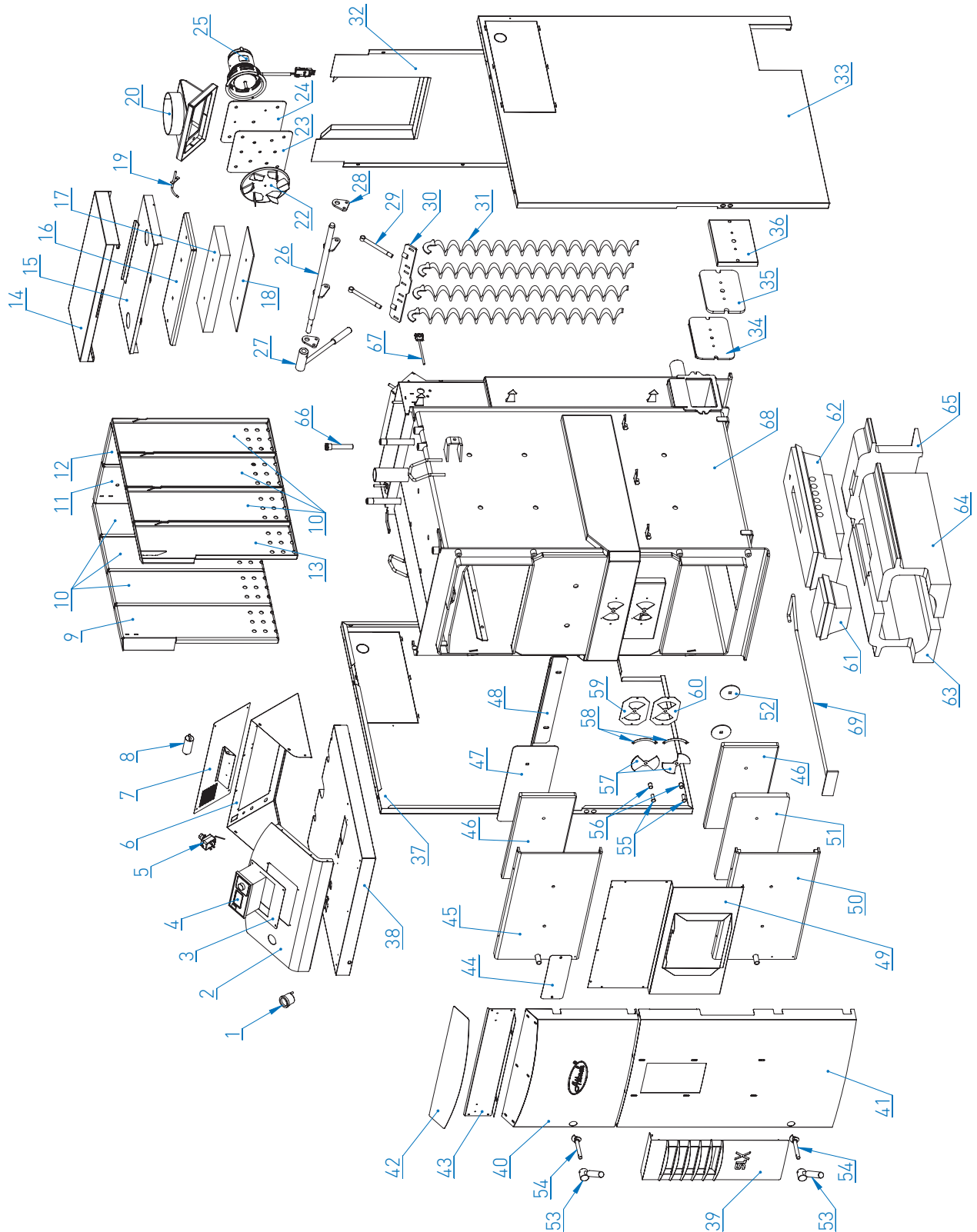

#	CODE	#	CODE
1	AT46C	43	SL20036C
2	SL20935A	44	SL20929A
3	DPD25221	45	DPD15016A
4	SL20092	46	DPD25220
5	SL20096A	47	SL20107
6	TS095A	48	SL20108
7	OT19C	49	ADF25478
8	SL20119A	50	SL20932
9	SL20120	51	SL20931
10	SL20914A	52	SL20928A
11	SL20022A	53	SL20111A
12	SL20913A	54	SL20097A
13	SL20912A	55	SL20124
14	SL20915A	56	SL20926A
15	DPO15009B	57	DPD25030
16	SL20122A	58	SL20121
17	SL20911	59	SL20033
18	SL20040	60	SL20927A
19	SL20041	61	SL20098A
20	DPD25059	62	DPV25095A
21	ADF25816	63	SL20123
22	DPD25223	64	DPD25030
23		65	DPV95086
24	DPD25080	66	DPD25420B
25	DPD25001B	67	DPD25430
26	DPV25081	68	DPD25216
27	DPD25016D	69	SL20032
28	DPV15925	70	DPV25203
29	DPV45035A	71	SL20118A
30	SL20919B	72	SL20095A
31	DPD25065	73	SL20129
32	DPV15921	74	DPT35004
33	ADF25921	75	DPT20001
34	SL20130	76	DPP35103
35	SL20128A	77	DPP35104
36	H30810	78	DPP35105
37	SL20916A	79	DPD25011
38	SL20055B	80	ADF25602
39	SL20034C	81	DPD25110
40	DPO15006D	82	SL20901
41	DPD15008A	83	DPC25005A
42	DPV25500		

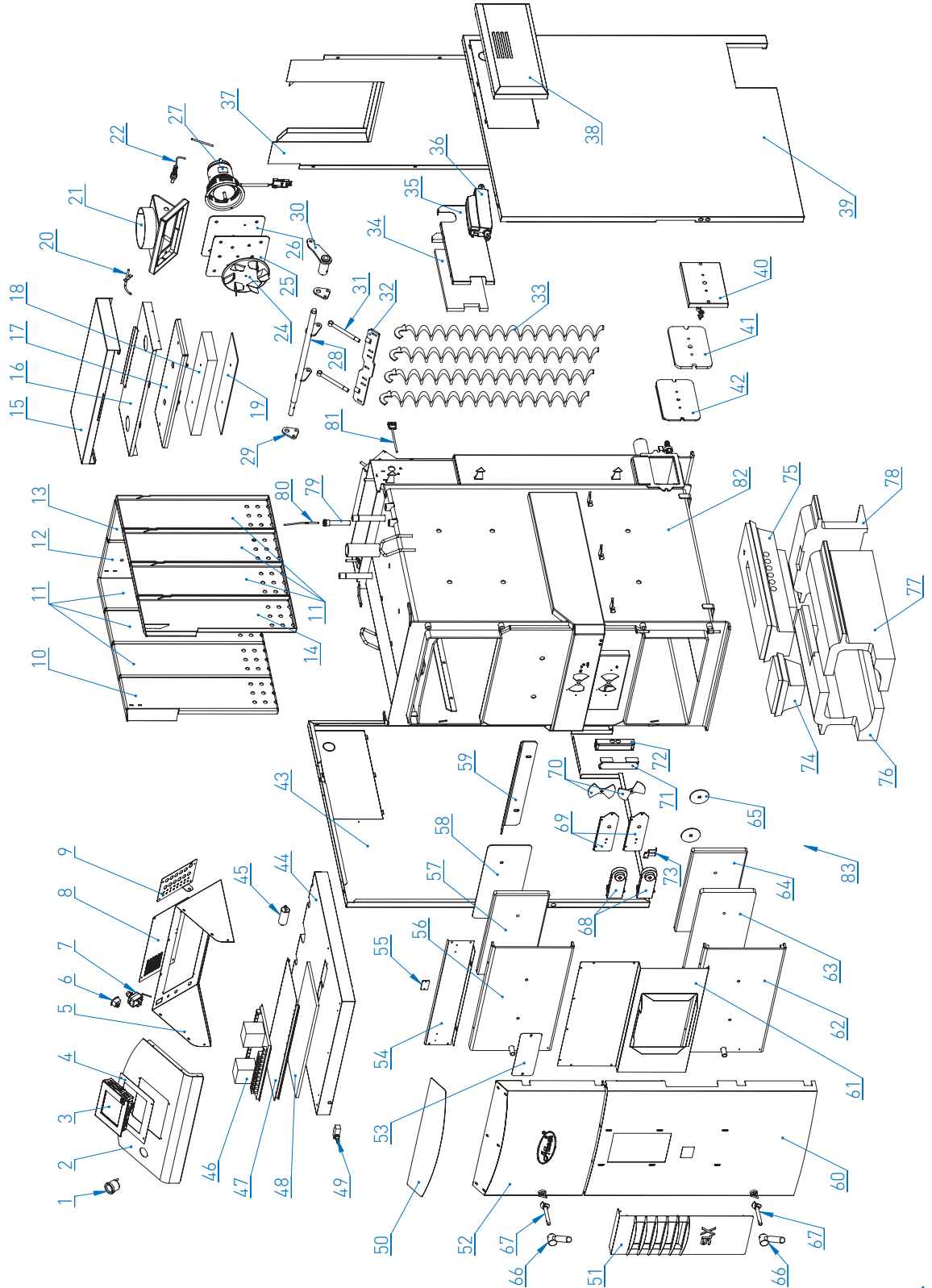

#	CODE	#	CODE
1	AT46C	35	DPO15006D
2	SL20935A	36	SL20036C
3	SL20102	37	SL20929A
4	DPD25073	38	SL20931
5	OT19C	39	SL20928A
6	SL20096A	40	SL20927A
7	SL20936A	41	SL20932
8	DPD25016A	42	SL20097A
9	SL20914A	43	SL20111A
10	SL20022A	44	SL20926A
11	SL20913A	45	DPD25030
12	SL20912A	46	SL20121
13	SL20915A	47	SL20033
14	DP015009B	48	SL20098A
15	SL20122A	49	DPV25095A
16	SL20911	50	SL20123
17	SL20040	51	DPV95086
18	SL20041	52	DPD25420B
19	DPD25059	53	DPD25430
20	SL20937	54	SP111
21	DPD25080	55	DPV25303
22	DPD25001B	56	SL20068
23	DPV25081	57	DK418
24	DPD25016D	58	SL20066
25	DPV15925	59	SL20067
26	DPV15924A	60	DPT35004
27	DPV45035A	61	DPT35005
28	DPD25065	62	DPP35103
29	DPV15921	63	DPP35104
30	ADF25921	64	DPP35105
31	SL20916A	65	DPD25011
32	SL20034C	66	DPD25110
33	DPV25500	67	SL20901
34	DPD15008A	68	DPC25005A

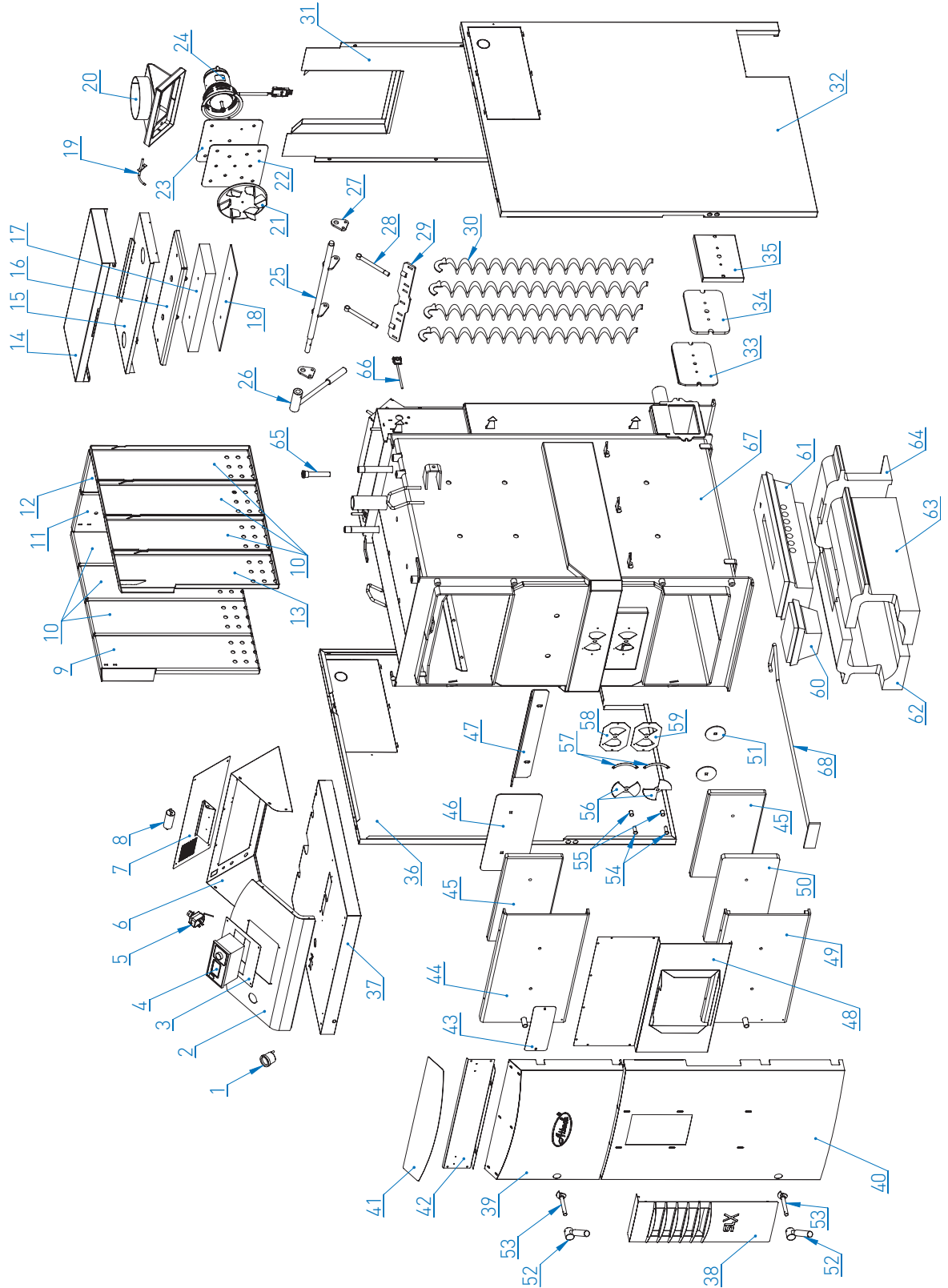

#	CODE	#	CODE
1	AT46C	42	SL20036C
2	SL20935A	43	SL20929A
3	DPD25221	44	DPD15016A
4	SL20092	45	DPD25220
5	SL20096A	46	SL20107
6	TS095A	47	SL20108
7	OT19C	48	ADF25478
8	SL20119A	49	SL20932
9	SL20120	50	SL20931
10	SL20914A	51	SL20928A
11	SL20022A	52	SL20111A
12	SL20913A	53	SL20097A
13	SL20912A	54	SL20124
14	SL20915A	55	SL20926A
15	DPO15009B	56	DPD25030
16	SL20122A	57	SL20121
17	SL20911	58	SL20033
18	SL20040	59	SL20927A
19	SL20041	60	SL20098A
20	DPD25059	61	DPV25095A
21	ADF25816	62	SL20123
22	DPD25223	63	DPD25030
23	DPD25080	64	DPV95086
24	DPD25001B	65	DPD25420B
25	DPV25081	66	DPD25430
26	DPD25016D	67	DPD25216
27	DPV15925	68	SL20032
28	DPV45035A	69	DPV25203
29	SL20919B	70	SL20118A
30	DPD25065	71	SL20095A
31	DPV15921	72	SL20129
32	ADF25921	73	DPT35004
33	SL20130	74	DPT35005
34	SL20128A	75	DPP35103
35	H30810	76	DPP35104
36	SL20916A	77	DPP35105
37	SL20055B	78	DPD25011
38	SL20034C	79	ADF25602
39	DPO15006D	80	DPD25110
40	DPD15008A	81	SL20901
41	DPV25500	82	DPC25005A

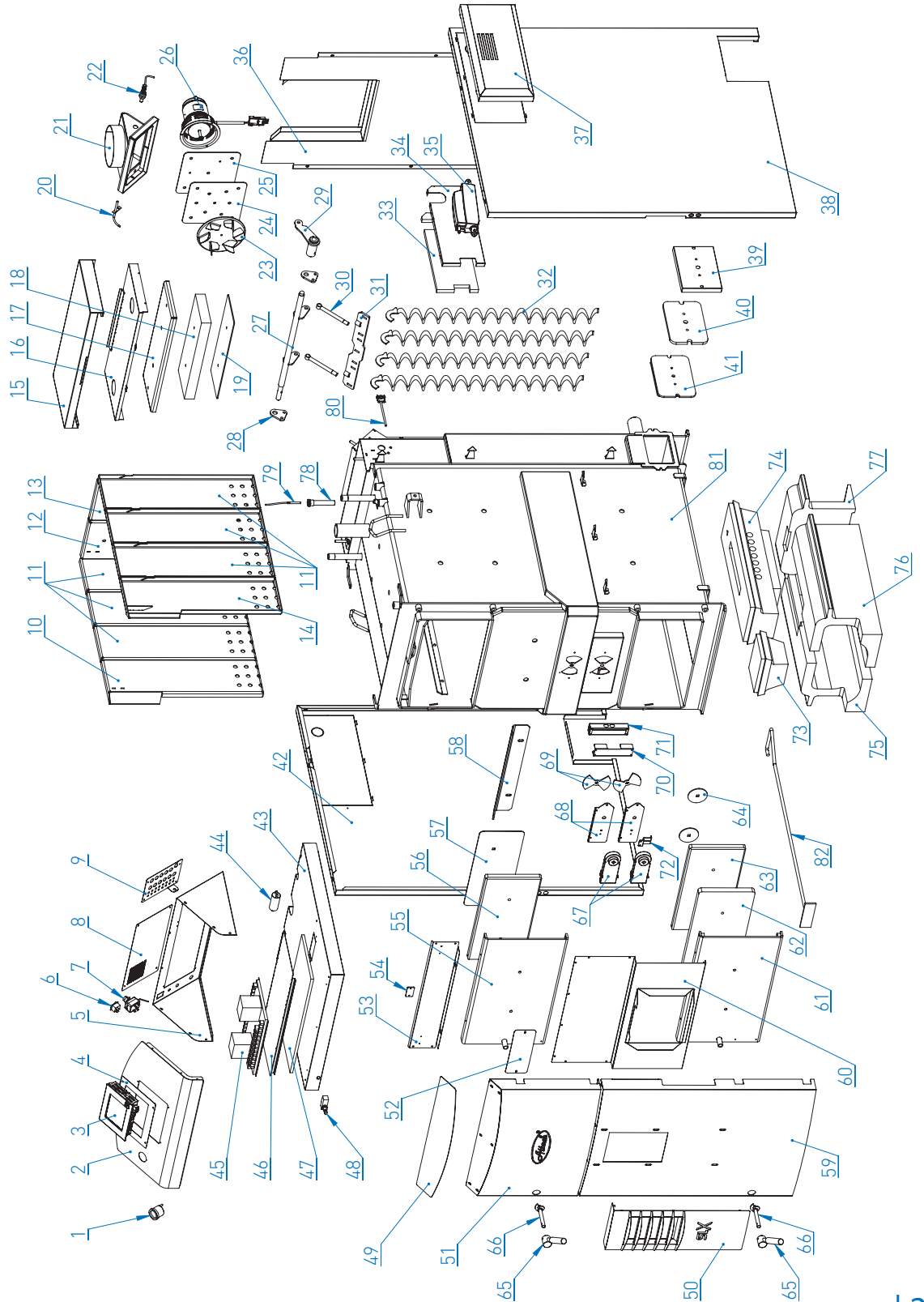

#	CODE	#	CODE
1	AT46C	35	DPO15006D
2	SL20935A	36	SL20036C
3	SL20102	37	SL20929A
4	DPD25073	38	SL20931
5	OT19C	39	SL20928A
6	SL20096A	40	SL20927A
7	SL20936A	41	SL20932
8	DPD25016A	42	SL20097A
9	SL20914A	43	SL20111A
10	SL20022A	44	SL20926A
11	SL20913A	45	DPD25030
12	SL20912A	46	SL20121
13	SL20915A	47	SL20033
14	DPO15009B	48	SL20098A
15	SL20122A	49	DPV25095A
16	SL20911	50	SL20123
17	SL20040	51	DPV95086
18	SL20041	52	DPD25420B
19	DPD25059	53	DPD25430
20	SL20937	54	SP111
21	DPD25080	55	DPV25303
22	DPD25001B	56	SL20068
23	DPV25081	57	DK418
24	DPD25016D	58	SL20066
25	DPV15925	59	SL20067
26	DPV15924A	60	DPT35004
27	DPV45035A	61	DPT35005
28	DPD25065	62	DPP35103
29	DPV15921	63	DPP35104
30	SL20940	64	DPP35105
31	SL20916A	65	DPD25011
32	SL20034C	66	DPD25110
33	DPV25500	67	SL20901
34	DPD15008A	68	DPC25005A

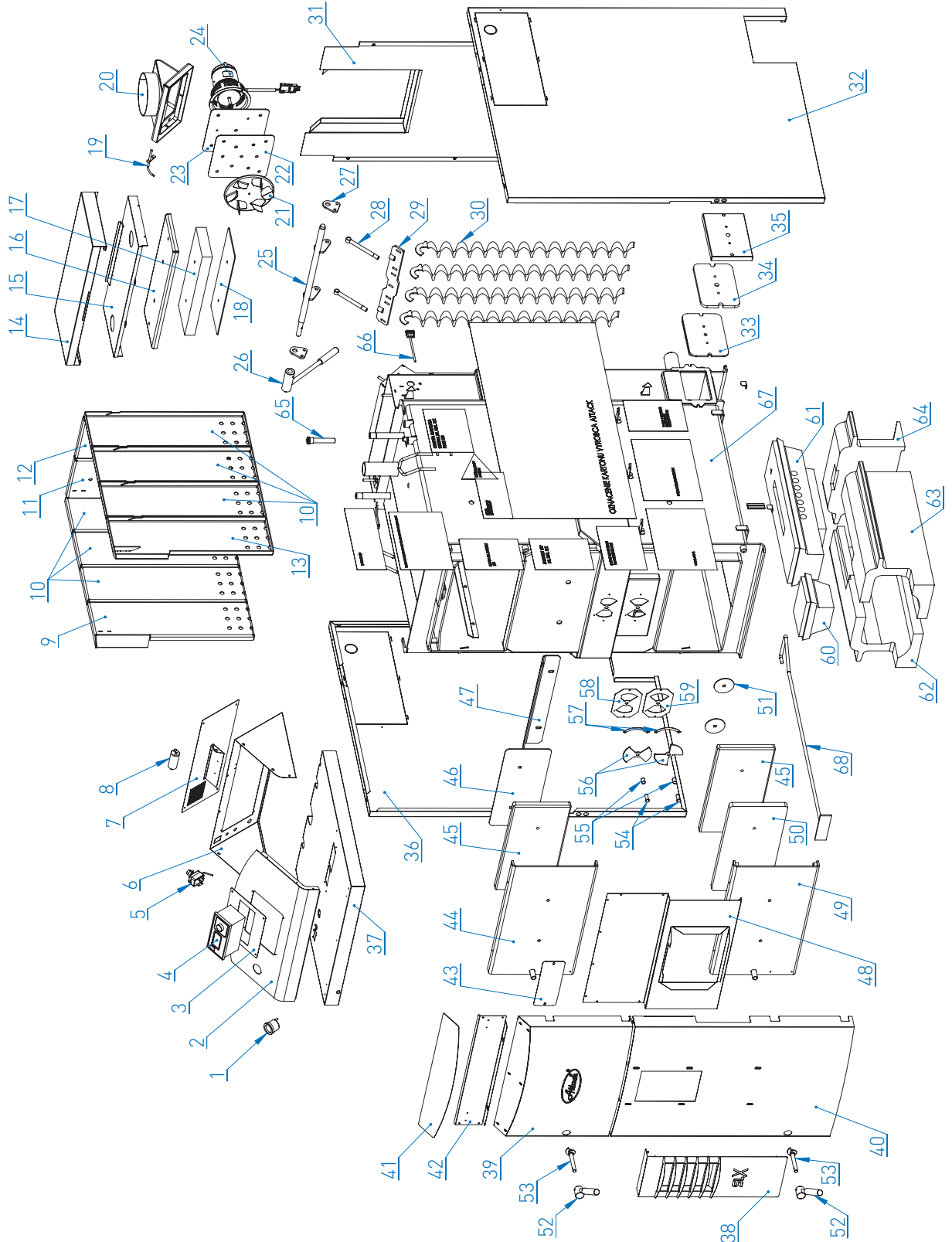

#	CODE	#	CODE
1	AT46C	42	SL20036C
2	SL20935A	43	SL20929A
3	DPD25221	44	DPD15016A
4	SL20092	45	DPD25220
5	SL20096A	46	SL20107
6	TS095A	47	SL20108
7	OT19C	48	ADF25478
8	SL20119A	49	SL20932
9	SL20120	50	SL20931
10	SL20914A	51	SL20928A
11	SL20022A	52	SL20111A
12	SL20913A	53	SL20097A
13	SL20912A	54	SL20124
14	SL20915A	55	SL20926A
15	DP015009B	56	DPD25030
16	SL20122A	57	SL20121
17	SL20911	58	SL20033
18	SL20040	59	SL20927A
19	SL20041	60	SL20098A
20	DPD25059	61	DPV25095A
21	ADF25816	62	SL20123
22	DPD25223	63	DPD25030
23	DPD25080	64	DPV95086
24	DPD25001B	65	DPD25420B
25	DPV25081	66	DPD25430
26	DPD25016D	67	DPD25216
27	DPV15925	68	SL20032
28	DPV45035A	69	DPV25203
29	SL20919B	70	SL20118A
30	DPD25065	71	SL20095A
31	DPV15921	72	SL20129
32	SL20940	73	DPT35004
33	SL20130	74	DPT35005
34	SL20128A	75	DPP35103
35	H30810	76	DPP35104
36	SL20916A	77	DPP35105
37	SL20055B	78	DPD25011
38	SL20034C	79	ADF25602
39	DP015006D	80	DPD25110
40	DPD15008A	81	SL20901
41	DPV25500	82	DPC25005A

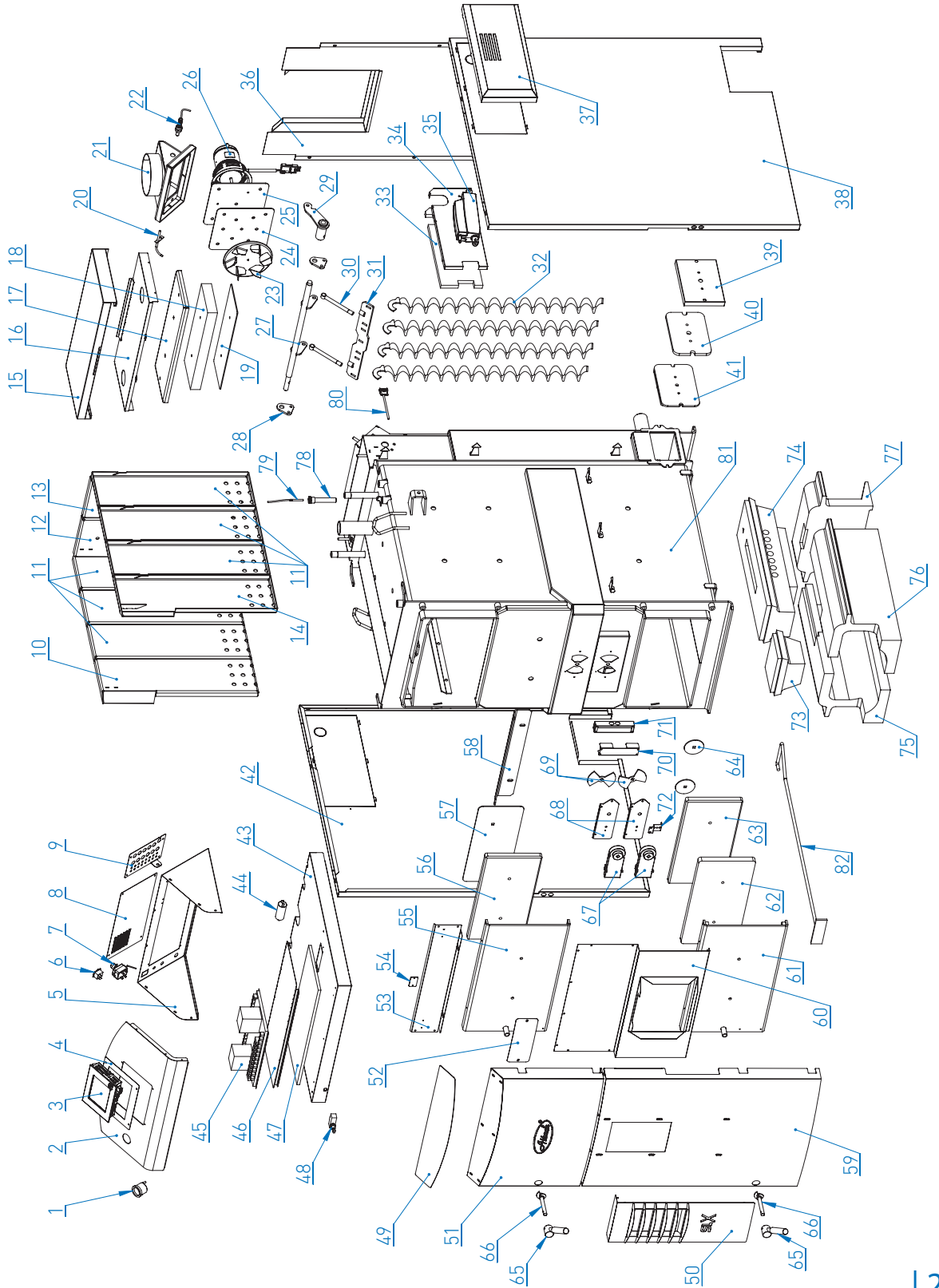

#	CODE	#	CODE
1	AT46C	36	DP015006D
2	SL20935A	37	SL40028A
3	SL20102	38	SL40915
4	DPD25073	39	SL20932
5	SL20096A	40	SL20097A
6	OT19C	41	SL20928A
7	SL20936A	42	SL20111A
8	DPD25016A	43	SL20926A
9	SL40908A	44	DPD25030
10	SL20022A	45	SL20121
11	SL20913A	46	SL20033
12	SL20912A	47	SL20931
13	SL40909A	48	SL20927A
14	SL40037	49	SL20098A
15	SL40039	50	DPV25095A
16	SL40912	51	SL20123
17	DPD25030	52	DPV95086
18	DPV25108	53	DPD25420B
19	DPD25059	54	DPD25430
20	SL20937	55	SP111
21	DPD40001	56	DPV25303
22	DPD25001B	57	SL20068
23	DPV45040	58	DK418
24	DPD25202D	59	SL20066
25	DPD45005	60	SL20067
26	DPV15928	61	DPT35004
27	DPV15924A	62	DPT45004
28	DPV45035A	63	DPP45103
29	DPD25065	64	DPP45104
30	DPV15921	65	DPP25104
31	SL20924	66	DPD25011
32	SL20916A	67	DPD25110
33	SL40027A	68	SL40901
34	DPV25500	69	DPC25005A
35	DPD15008A	70	

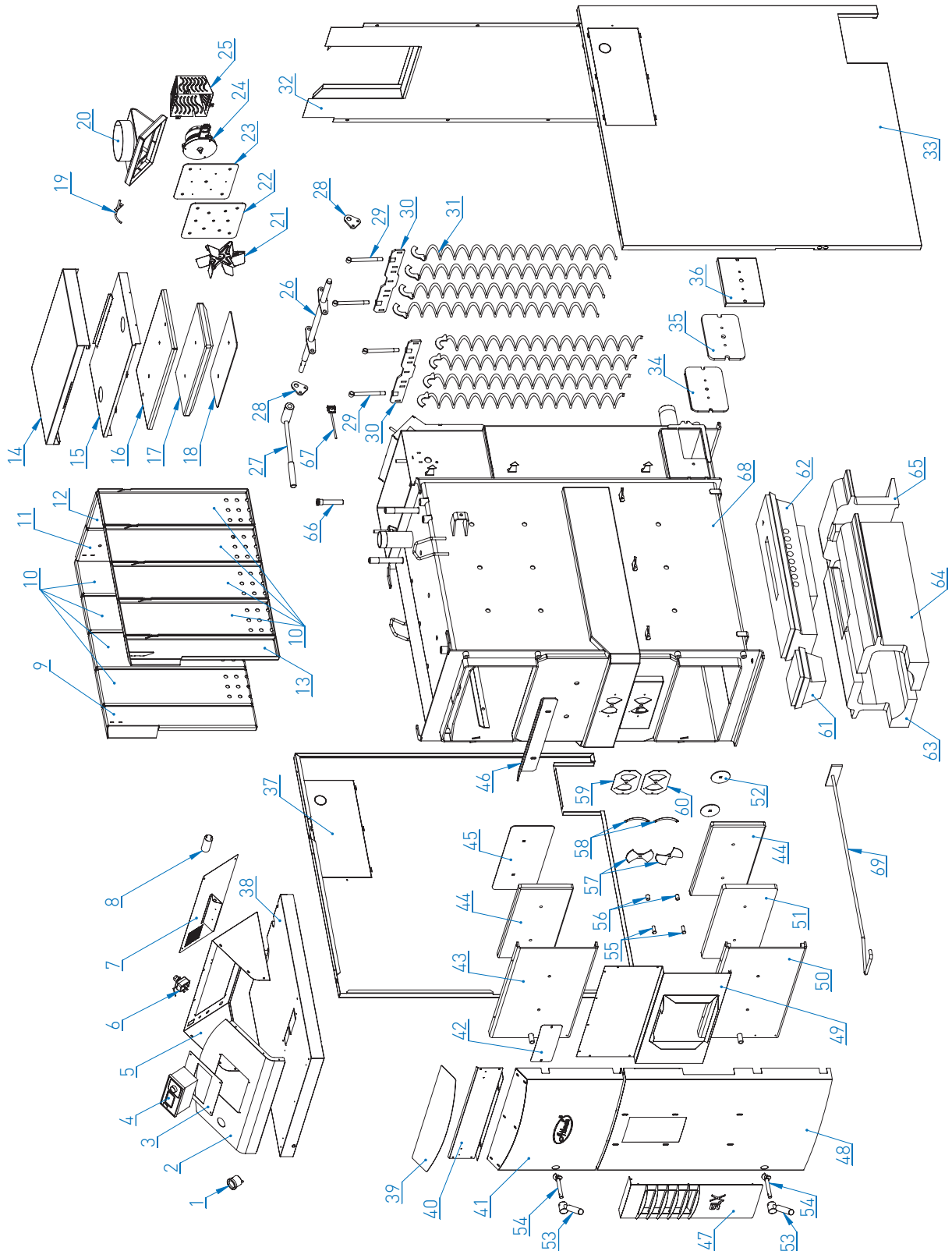

#	CODE	#	CODE
1	AT46C	42	DPO15006D
2	SL20935A	43	SL40028A
3	SL20092	44	SL40915
4	DPD25221	45	DPD25016A
5	SL20096A	46	DPD25220
6	TS095A	47	SL20107
7	OT19C	48	SL20108
8	SL20119A	49	ADF25478
9	SL20120	50	SL20932
10	SL40908A	51	SL20931
11	SL20022A	52	SL20928A
12	SL20913A	53	SL20111A
13	SL20912A	54	SL20097A
14	SL40909A	55	SL20124
15	SL40037	56	SL20926A
16	SL40039	57	DPD25030
17	SL40912	58	SL20121
18	DPD25030	59	SL20033
19	DPV25108	60	SL20927A
20	DPD25059	61	SL20098A
21	ADF25816	62	DPV25095A
22	DPD25223	63	SL20123
23	DPD40001	64	DPV95086
24	DPD25001B	65	DPD25420B
25	DPV45040	66	DPD25430
26	DPD25202D	67	DPD25216
27	DPD45005	68	SL20032
28	DPV15928	69	DPV25203
29	DPV45035A	70	SL20118A
30	SL40913	71	SL20095A
31	DPD25065	72	SL20129
32	DPV15921	73	DPT35004
33	SL20924	74	DPT45004
34	SL20130	75	DPP45103
35	SL20128A	76	DPP45104
36	H30810	77	DPP25104
37	SL20916A	78	DPD25011
38	SL20055B	79	ADF25602
39	SL40027A	80	DPD25110
40	DPV25500	81	SL40901
41	DPD15008A	82	DPD25005A

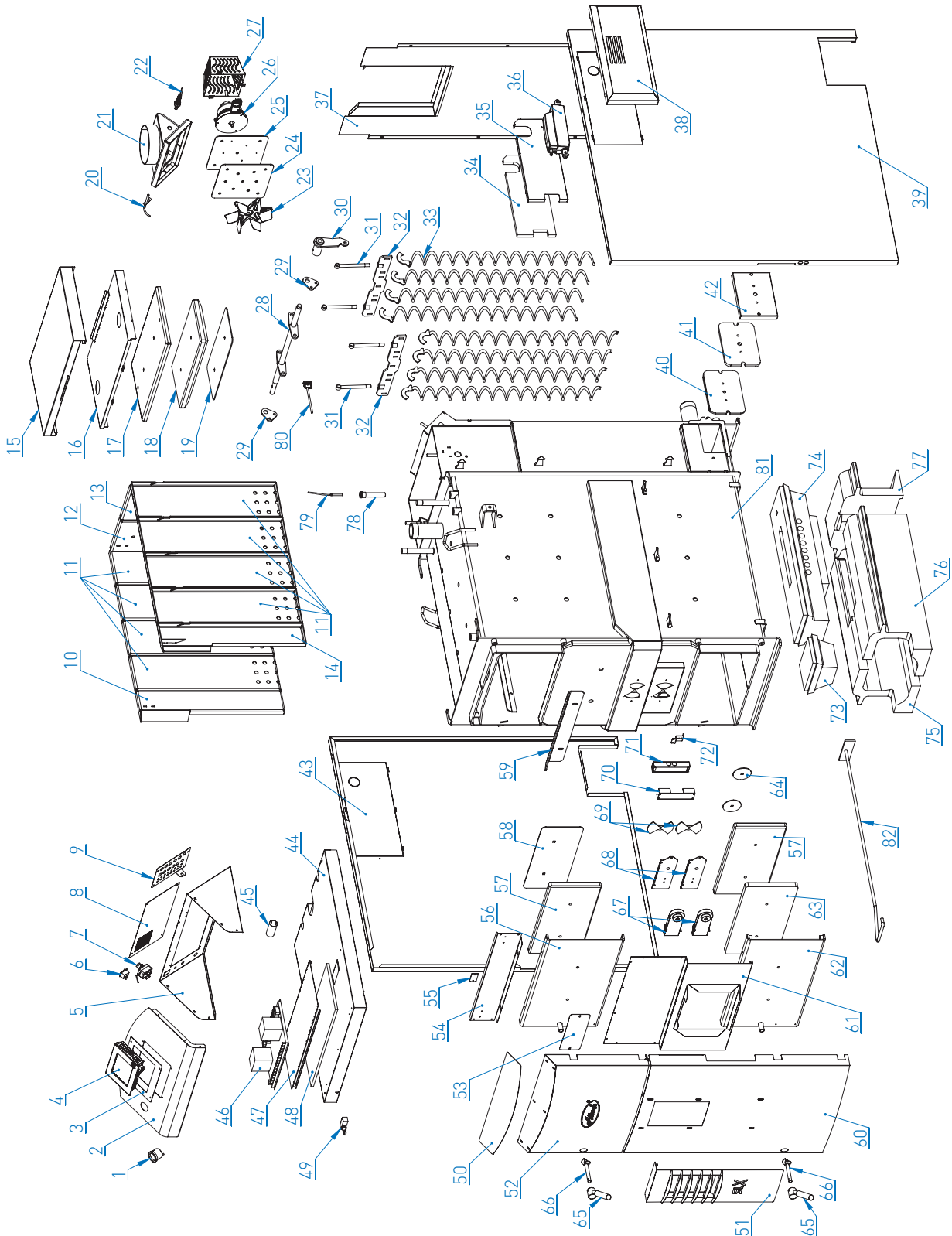

#	CODE	#	CODE
1	AT46C	36	DP015006D
2	SL20935A	37	SL40028A
3	SL20102	38	SL40915
4	DPD25073	39	SL20932
5	SL20096A	40	SL20097A
6	OT19C	41	SL20928A
7	SL20936A	42	SL20111A
8	DPD25016A	43	SL20926A
9	SL40908A	44	DPD25030
10	SL20022A	45	SL20121
11	SL20913A	46	SL20033
12	SL20912A	47	SL20931
13	SL40909A	48	SL20927A
14	SL40037	49	SL20098A
15	SL40039	50	DPV25095A
16	SL40912	51	SL20123
17	DPD25030	52	DPV95086
18	DPV25108	53	DPD25420B
19	DPD25059	54	DPD25430
20	SL20937	55	SP111
21	DPD40001	56	DPV25303
22	DPD25001B	57	SL20068
23	DPV45040	58	DK418
24	DPD25202D	59	SL20066
25	DPD45005	60	SL20067
26	DPV15928	61	DPT35004
27	DPV15924A	62	DPT45004
28	DPV45035A	63	DPP45103
29	DPD25065	64	DPP45104
30	DPV15921	65	DPP25104
31	SL20924	66	DPD25011
32	SL20916A	67	DPD25110
33	SL40027A	68	SL40901
34	DPV25500	69	DPC25005A
35	DPD15008A	70	

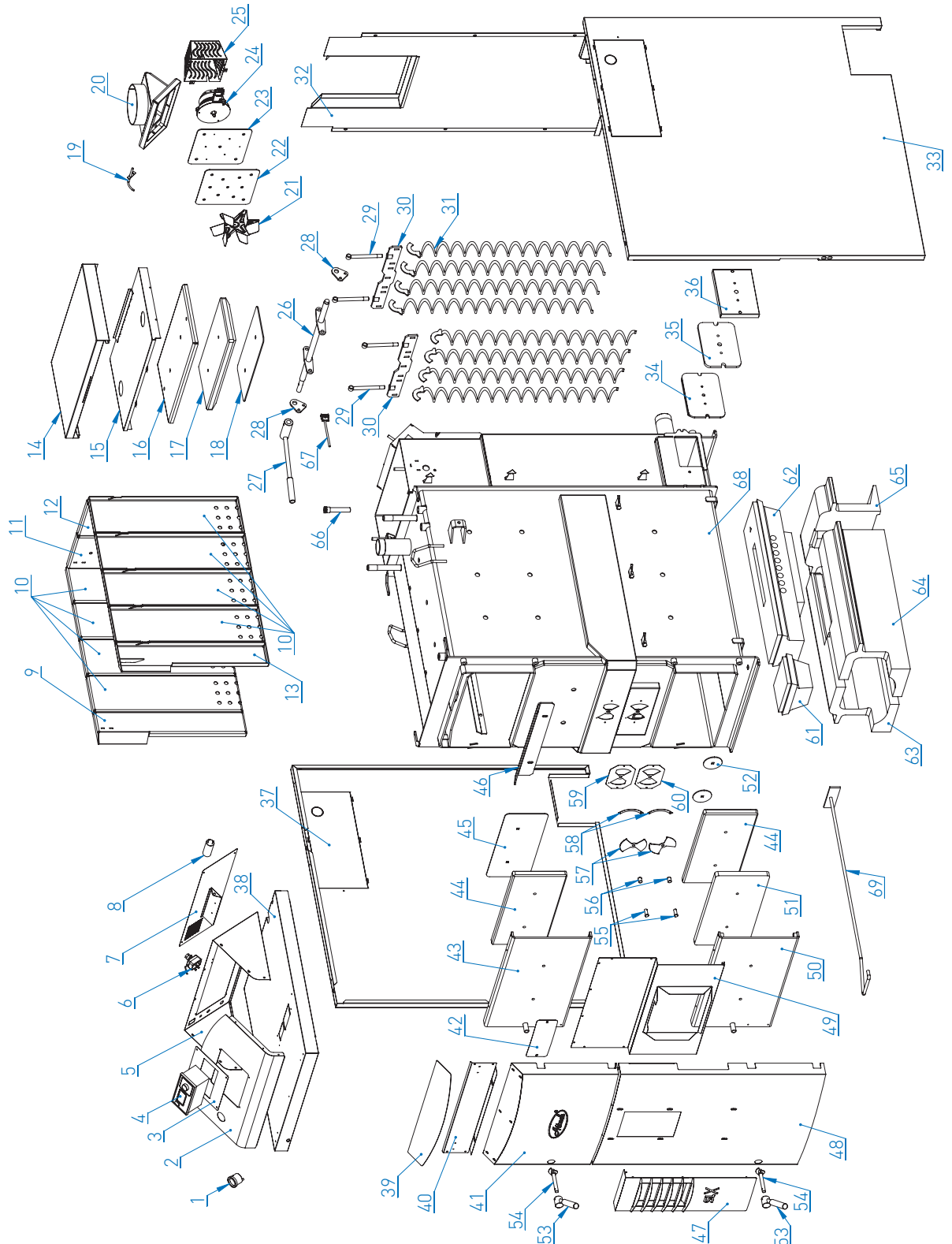

#	CODE	#	CODE
1	AT46C	42	DP015006D
2	SL20935A	43	SL40028A
3	SL20092	44	SL40915
4	DPD25221	45	DPD25016A
5	SL20096A	46	DPD25220
6	TS095A	47	SL20107
7	OT19C	48	SL20108
8	SL20119A	49	ADF25478
9	SL20120	50	SL20932
10	SL40908A	51	SL20931
11	SL20022A	52	SL20928A
12	SL20913A	53	SL20111A
13	SL20912A	54	SL20097A
14	SL40909A	55	SL20124
15	SL40037	56	SL20926A
16	SL40039	57	DPD25030
17	SL40912	58	SL20121
18	DPD25030	59	SL20033
19	DPV25108	60	SL20927A
20	DPD25059	61	SL20098A
21	ADF25816	62	DPV25095A
22	DPD25223	63	SL20123
23	DPD40001	64	DPV95086
24	DPD25001B	65	DPD25420B
25	DPV45040	66	DPD25430
26	DPD25202D	67	DPD25216
27	DPD45005	68	SL20032
28	DPV15928	69	DPV25203
29	DPV45035A	70	SL20118A
30	SL40913	71	SL20095A
31	DPD25065	72	SL20129
32	DPV15921	73	DPT35004
33	SL20924	74	DPT45004
34	SL20130	75	DPP45103
35	SL20128A	76	DPP45104
36	H30810	77	DPP25104
37	SL20916A	78	DPD25011
38	SL20055B	79	ADF25602
39	SL40027A	80	DPD25110
40	DPV25500	81	SL40901
41	DPD15008A	82	DPC25005A

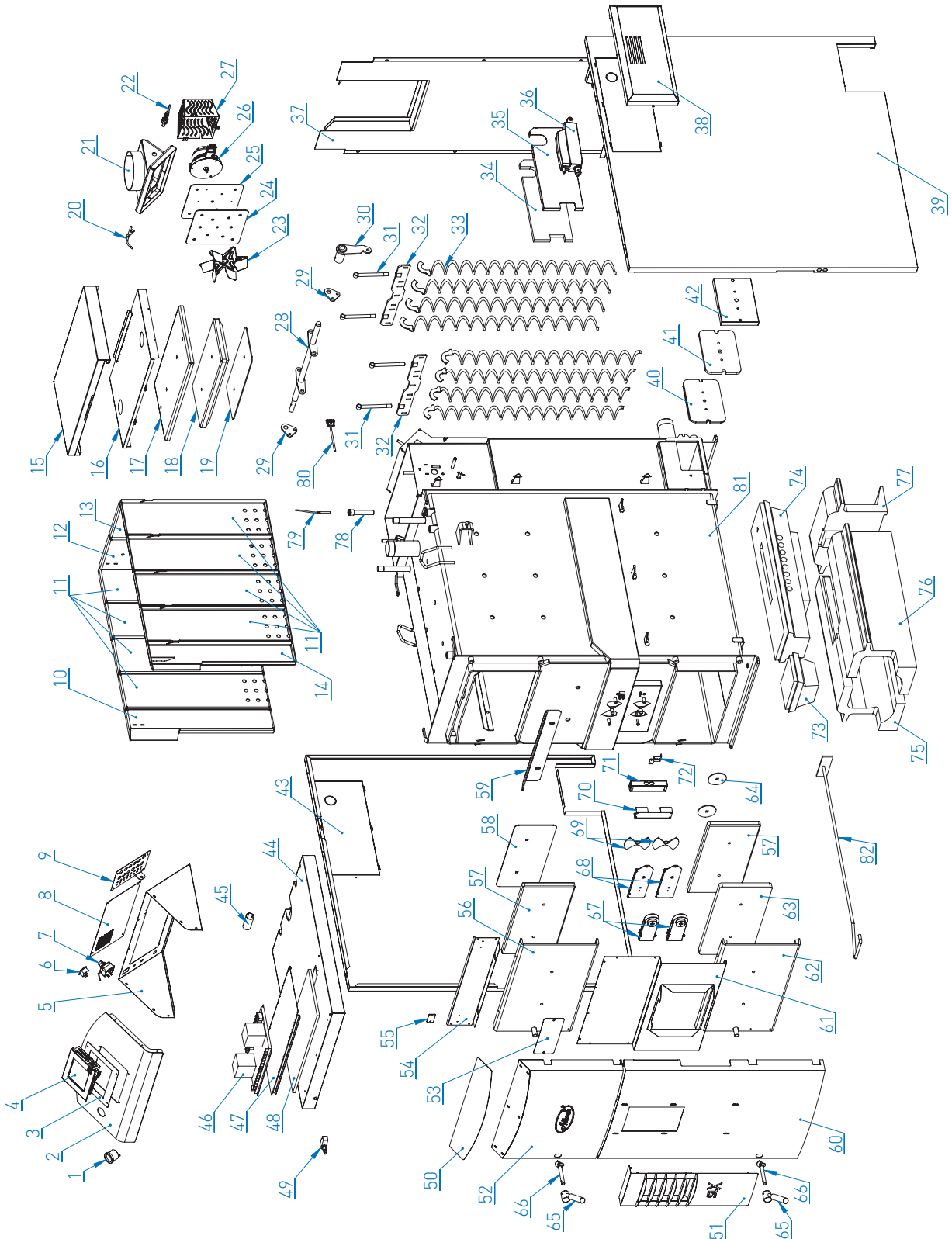

#	CODE	#	CODE
1	AT46C	36	DPO15006D
2	SL20935A	37	SL40028A
3	SL20102	38	SL40915
4	DPD25073	39	SL20932
5	SL20096A	40	SL20097A
6	OT19C	41	SL20928A
7	SL20936A	42	SL20111A
8	DPD25016A	43	SL20926A
9	SL40908A	44	DPD25030
10	SL20022A	45	SL20121
11	SL20913A	46	SL20033
12	SL20912A	47	SL20931
13	SL40909A	48	SL20927A
14	SL40037	49	SL20098A
15	SL40039	50	DPV25095A
16	SL40912	51	SL20123
17	DPD25030	52	DPV95086
18	DPV25108	53	DPD25420B
19	DPD25059	54	DPD25430
20	SL20937	55	SP111
21	DPD40001	56	DPV25303
22	DPD25001B	57	SL20068
23	DPV45040	58	DK418
24	DPD25202D	59	SL20066
25	DPD45005	60	SL20067
26	DPV15928	61	DPT35004
27	DPV15924A	62	DPT45004
28	DPV45035A	63	DPP45103
29	DPD25065	64	DPP45104
30	DPV15921	65	DPP25104
31	ADF25921	66	DPD25011
32	SL20916A	67	DPD25110
33	SL40027A	68	SL40901
34	DPV25500	69	DPC25005A
35	DPD15008A	70	

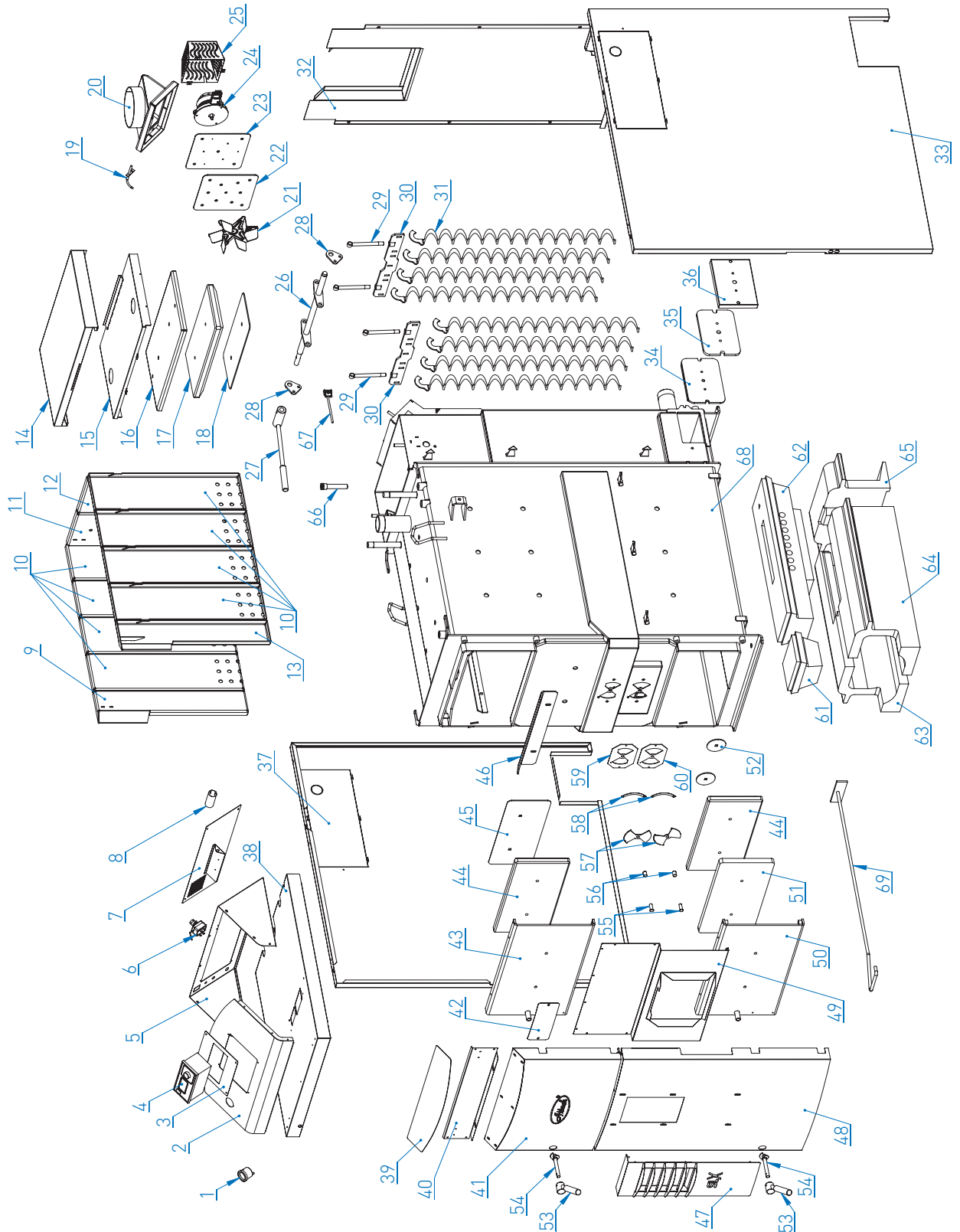

#	CODE	#	CODE
1	AT46C	42	DP015006D
2	SL20935A	43	SL40028A
3	SL20092	44	SL40915
4	DPD25221	45	DPD25016A
5	SL20096A	46	DPD25220
6	TS095A	47	SL20107
7	OT19C	48	SL20108
8	SL20119A	49	ADF5478
9	SL20120	50	SL20932
10	SL40908A	51	SL20931
11	SL20022A	52	SL20928A
12	SL20913A	53	SL20111A
13	SL20912A	54	SL20097A
14	SL40909A	55	SL20124
15	SL40037	56	SL20926A
16	SL40039	57	DPD25030
17	SL40912	58	SL20121
18	DPD25030	59	SL20033
19	DPV25108	60	SL20927A
20	DPD25059	61	SL20098A
21	ADF25816	62	DPV25095A
22	DPD25223	63	SL20123
23	DPD40001	64	DPV95086
24	DPD25001B	65	DPD25420B
25	DPV45040	66	DPD25430
26	DPD25202D	67	DPD25216
27	DPD45005	68	SL20032
28	DPV15928	69	DPV25203
29	DPV45035A	70	SL20118A
30	SL40913	71	SL20095A
31	DPD25065	72	SL20129
32	DPV15921	73	DPT35004
33	ADF25921	74	DPT45004
34	SL20130	75	DPP45103
35	SL20128A	76	DPP45104
36	H30810	77	DPP25104
37	SL20916A	78	DPD25011
38	SL20055B	79	ADF25602
39	SL40027A	80	DPD25110
40	DPV25500	81	SL40901
41	DPD15008A	82	DPC25005A

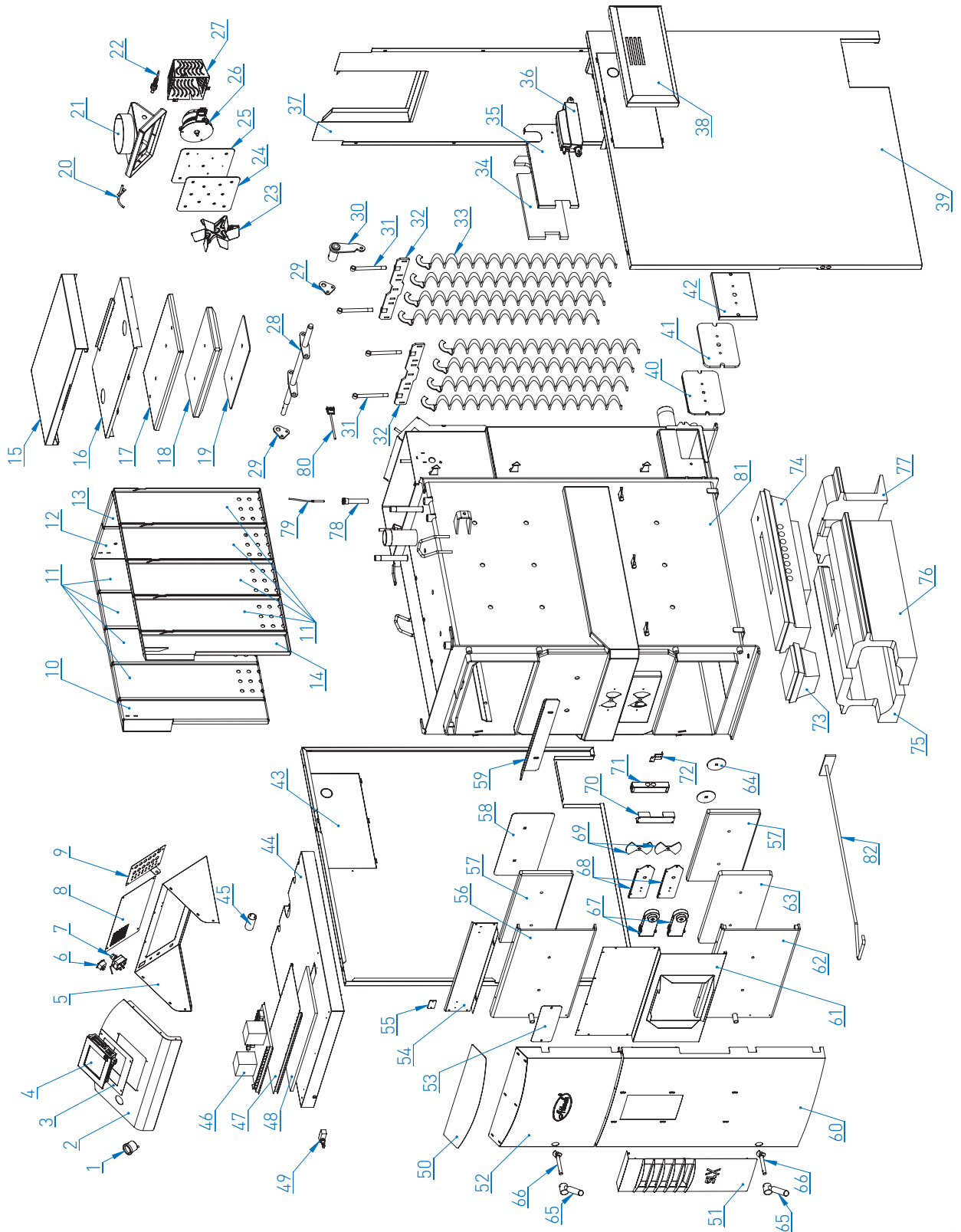

#	CODE	#	CODE
1	AT46C	36	DP015006D
2	SL20935A	37	SL40028A
3	SL20102	38	SL40915
4	DPD25073	39	SL20932
5	SL20096A	40	SL20097A
6	OT19C	41	SL20928A
7	SL20936A	42	SL20111A
8	DPD25016A	43	SL20926A
9	SL40908A	44	DPD25030
10	SL20022A	45	SL20121
11	SL20913A	46	SL20033
12	SL20912A	47	SL20931
13	SL40909A	48	SL20927A
14	SL40037	49	SL20098A
15	SL40039	50	DPV25095A
16	SL40912	51	SL20123
17	DPD25030	52	DPV95086
18	DPV25108	53	DPD25420B
19	DPD25059	54	DPD25430
20	SL20937	55	SP111
21	DPD40001	56	DPV25303
22	DPD25001B	57	SL20068
23	DPV45040	58	DK418
24	DPD25202D	59	SL20066
25	DPD45005	60	SL20067
26	DPV15928	61	DPT35004
27	DPV15924A	62	DPT45004
28	DPV45035A	63	DPP45103
29	DPD25065	64	DPP45104
30	DPV15921	65	DPP25104
31	SL20940	66	DPD25011
32	SL20916A	67	DPD25110
33	SL40027A	68	SL40901
34	DPV25500	69	DPC25005A
35	DPD15008A	70	

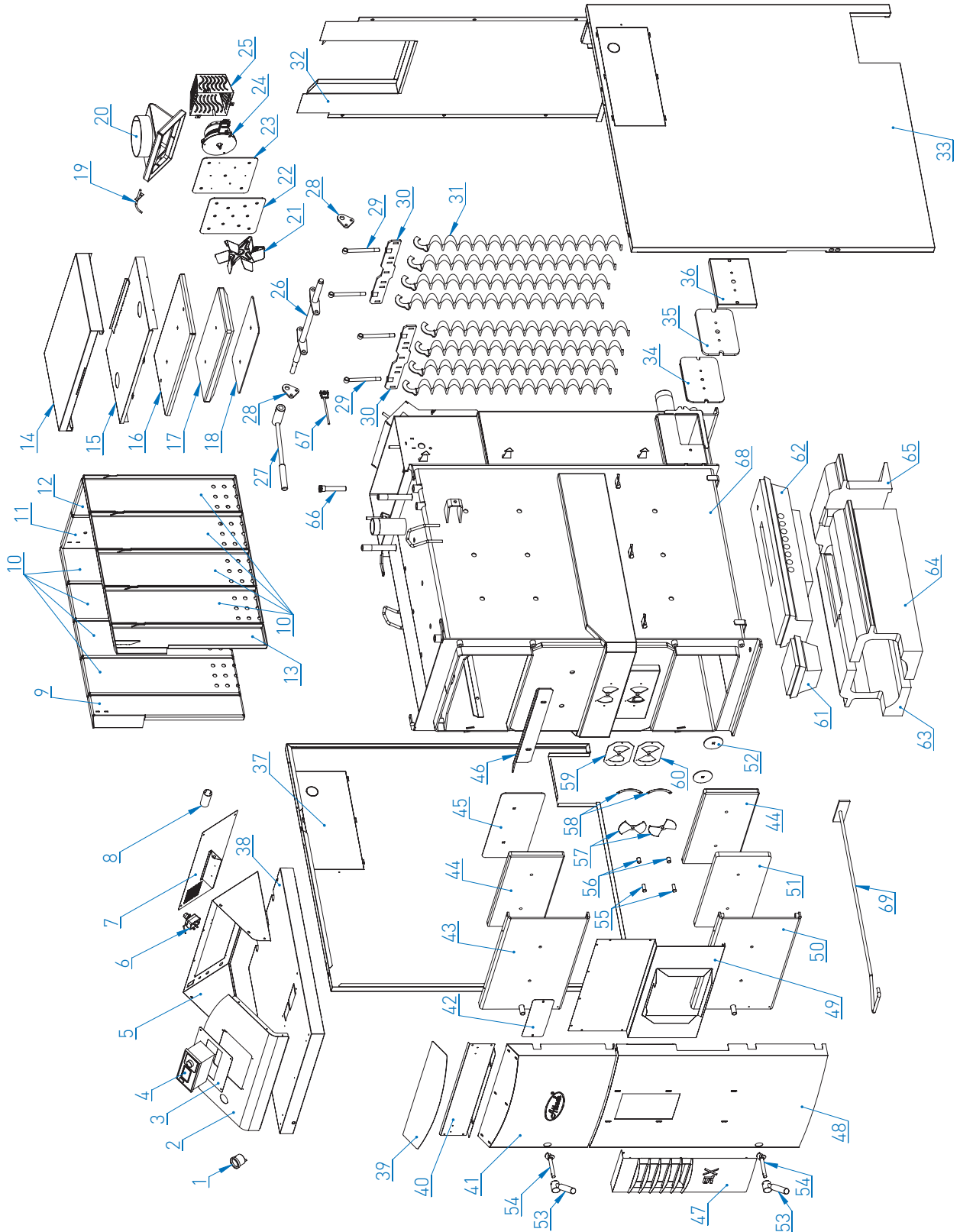

#	CODE	#	CODE
1	AT46C	42	DP015006D
2	SL20935A	43	SL40028A
3	SL20092	44	SL40915
4	DPD25221	45	DPD25016A
5	SL20096A	46	DPD25220
6	TS095A	47	SL20107
7	OT19C	48	SL20108
8	SL20119A	49	ADF25478
9	SL20120	50	SL20932
10	SL40908A	51	SL20931
11	SL20022A	52	SL20928A
12	SL20913A	53	SL20111A
13	SL20912A	54	SL20097A
14	SL40909A	55	SL20124
15	SL40037	56	SL20926A
16	SL40039	57	DPD25030
17	SL40912	58	SL20121
18	DPD25030	59	SL20033
19	DPV25108	60	SL20927A
20	DPD25059	61	SL20098A
21	ADF25816	62	DPV25095A
22	DPD25223	63	SL20123
23	DPD40001	64	DPV95086
24	DPD25001B	65	DPD25420B
25	DPV45040	66	DPD25430
26	DPD25202D	67	DPD25216
27	DPD45005	68	SL20032
28	DPV15928	69	DPV25203
29	DPV45035A	70	SL20118A
30	SL40913	71	SL20095A
31	DPD25065	72	SL20129
32	DPV15921	73	DPT35004
33	SL20940	74	DPT45004
34	SL20130	75	DPP45103
35	SL20128A	76	DPP45104
36	H30810	77	DPP25104
37	SL20916A	78	DPD25011
38	SL20055B	79	ADF25602
39	SL40027A	80	DPD25110
40	DPV25500	81	SL40901
41	DPD15008A	82	DPC25005A

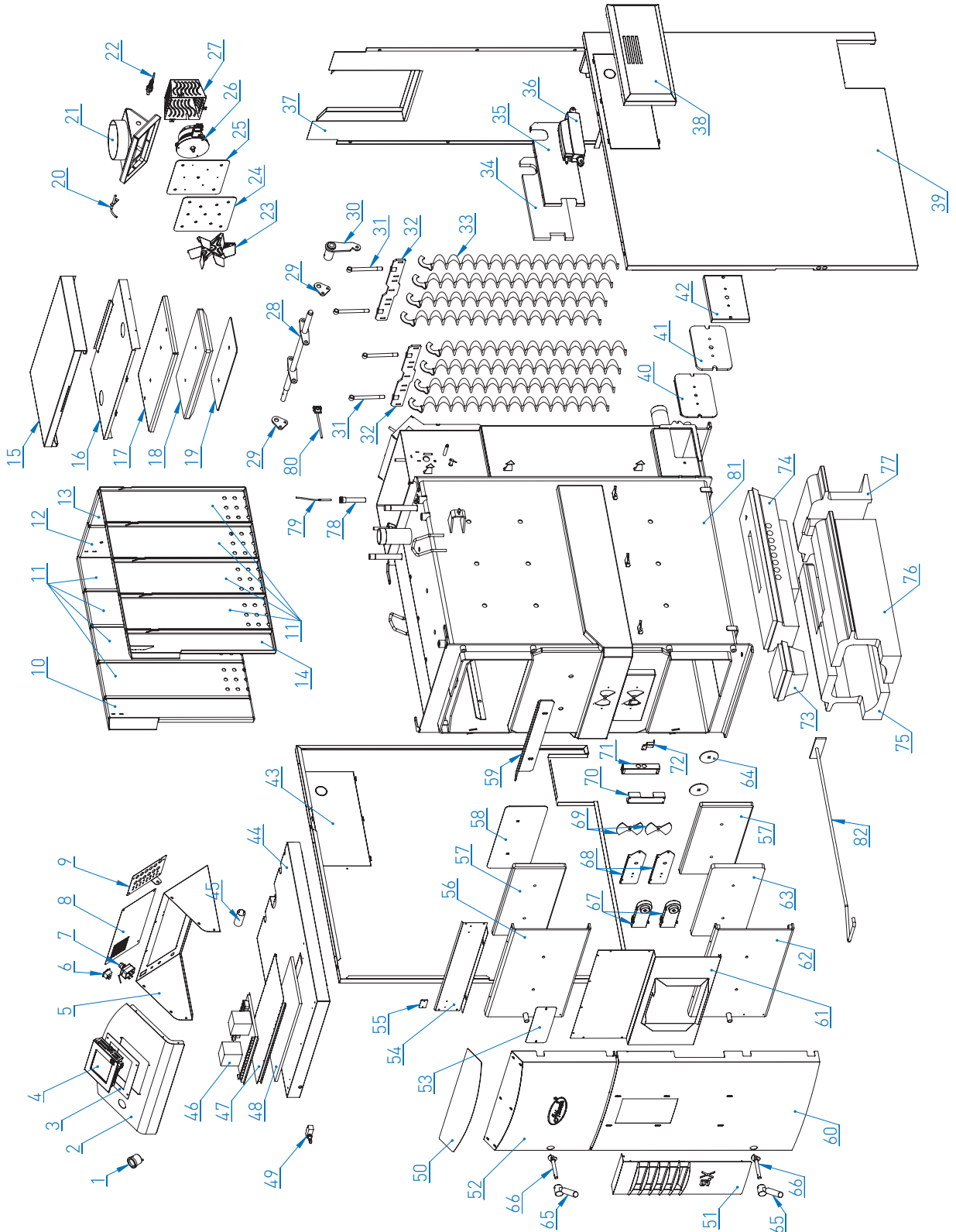

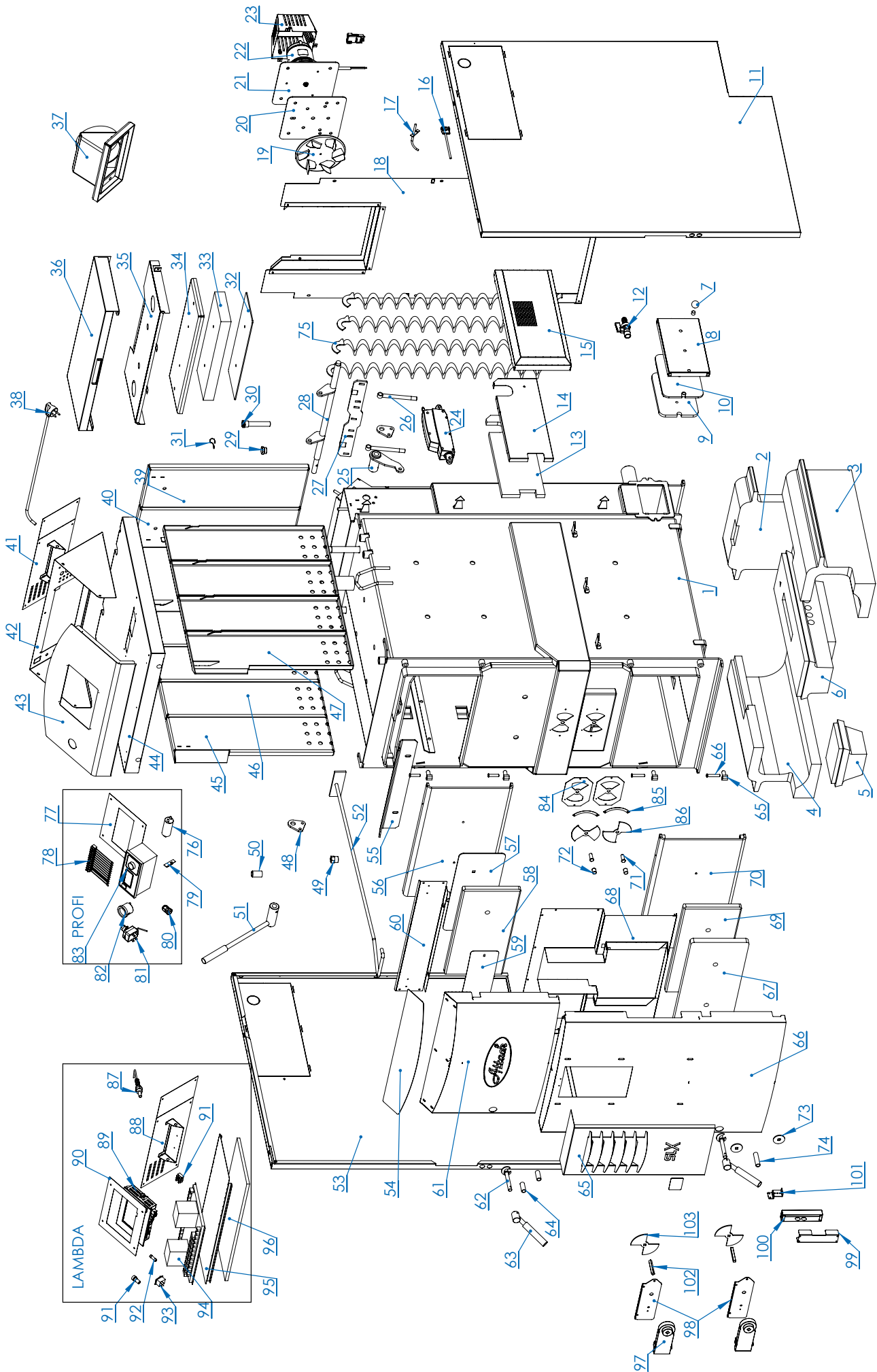

		PROFI	
#	CODE	#	CODE
76	DPD25016A		
77	SL20102A		
78	DPD15030		
79	DPD25034		
80	TS094A		
81	OT19C		
82	AT46C		
83	DPD25073		
84	SL20066		
85	DK418		
86	SL20068		

		LAMBDA	
#	CODE	#	CODE
87	DPD25223		
88	SL20936C		
89	DPD25221		do/to 5/2019
	ADF25641		od/from 6/2019
90	SL20092A		
91	TH05A		
92	TH06A		
93	TS095A		
94	DPD25220		
95	SL20107		
96	SL20108		
97	DPD25216		
98	SL20032		
99	SL20118A		
100	SL20095A		
101	SL20129		
102	DPV25301A		
103	DPV25203		

49	OT11		
50	DPP25005		
51	DPV15924A		
52	DPC25005A		
53	SL20036D	20-35	
	SL40028B	40-55	
54	SL20932		
55	SL20033		
56	SL20926A		
57	SL20121		
58	DPD25030A		
59	SL20111C		
60	SL20097B		
61	SL20928B		
62	DPD25430		
63	DPD25420B		
64	DPV15087		
65	SL20961		
66	SL20927B		
67	SL20123A		
68	SL20098C		
69	DPD25030A		
70	DPV25095A		
71	SP111		
72	DPV25303		
73	DPV15086		
74	SL20134		
75	ADF25921	25,30,50,55	
	SL20924	20,35,40,45	

25	SL20919B	20-35	
	SL40913	40-55	
26	DPD25065		
27	DPV15921		
	DPV15925	20-35	
28	DPV15928	40-55	
29	DPD25029		
30	DPD25101		
31	TS106		
	SL20041	20-35	
32	DPV25108	40-55	
	SL20040	20-35	
33	DPD25030A	40-55	
	SL20911	20-35	
34	SL40912	40-55	
	SL20122B	20-35	
35	SL40039A	40-55	
	DPA15010A	20-35	
36	SL40037B	40-55	
	SL20937	SLXP	
37	ADF25816	SLXL	
	TS091		
38	SL20025A		
39	SL20913A		
40	SL20936C		
41	SL20096C		
42	SL20935C		
43	SL20929C	20-35	
44	SL40915B	40-55	
	SL20914A	20-35	
45	SL40908A	40-55	
46	SL20022A		
	SL20915A	20-35	
47	SL40909A	40-55	
48	DPV45035A		

#	CODE		
1	SL20901	20-35	
	SL40901	40-55	
2	DPP35105	20-35	
	DPP25104	40-55	
3	DPP35104	20-35	
	DPP45104	40-55	
4	DPP35103	20-35	
	DPP45103	40-55	
5	DPT35004		
	DPT20001	20,25	
6	DPT35005	30,35	
	DPT45004	40-55	
7	DPD25069		
8	DPA15905A		
9	DPD15008A		
10	DPV25500A		
11	SL20034D	20-35	
	SL40027B	40-55	
12	TS103		
13	SL20130		
14	SL20128A		
15	SL20055C		
16	DPD25110		
17	DPD25059		
18	SL20916B		
19	DPD25080	20-35	
	DPD40001	40-55	
20	DPD25001B	20-35	
	DPV25081	20-35	
21	DPV45040	40-55	
	DPD25016D	20-35	
22	DPD25202D	40-55	
23	DPA45011	40-55	
24	H30810		

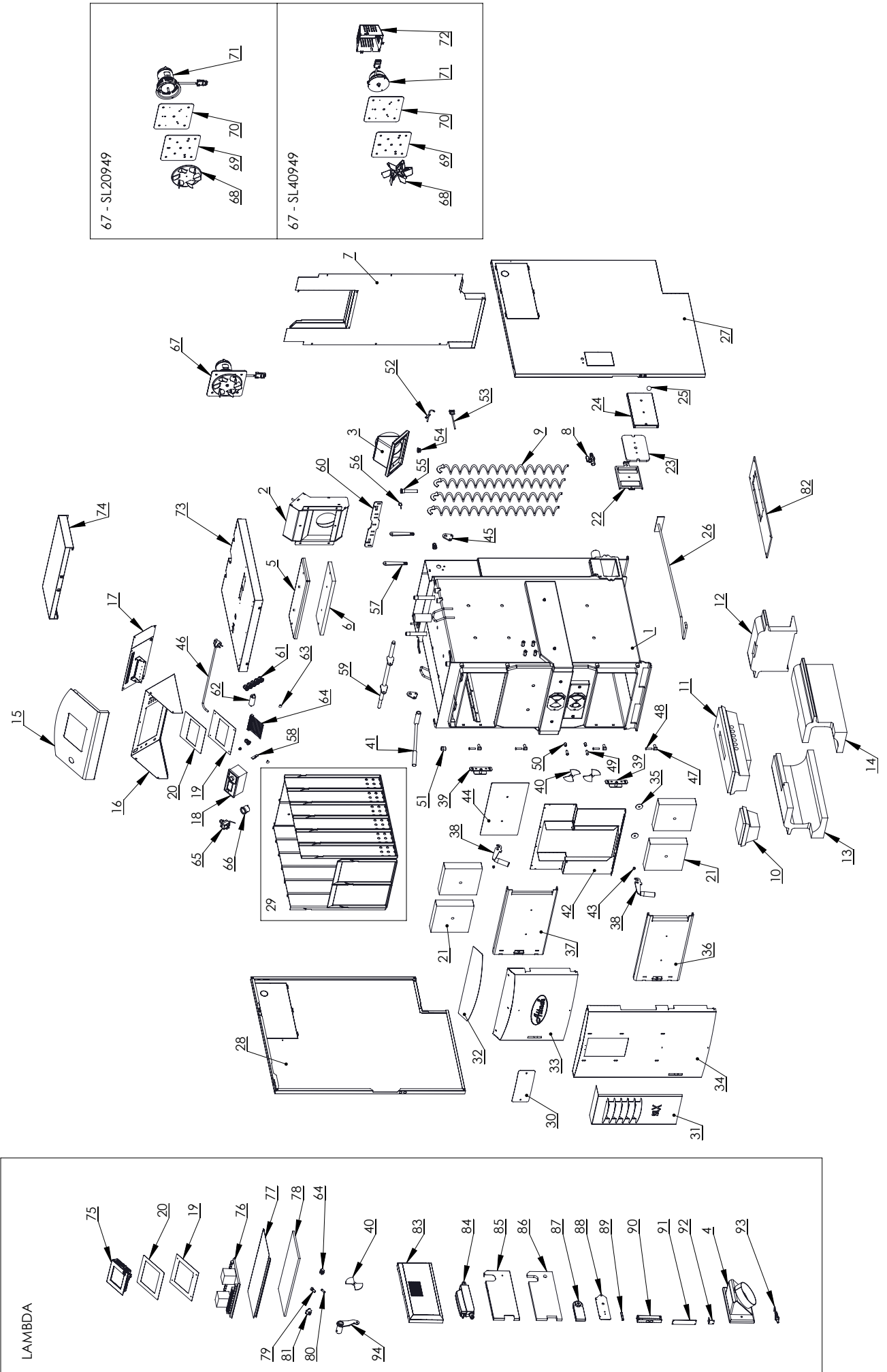

#	CODE	TYPE
1	SL20901G	SLX20-35
	SL40901G	SLX40-55
2	SL40907H	SLX20-55
3	SL20937B	SLX20-55 PROFI
4	SL20985	SLX20-55 LAMBDA
5	SL20043D	SLX20-35
	SL40919	SLX40-55
6	SL20040	SLX20-35
	SL40044A	SLX40-55
7	SL20916D	SLX20-55
8	TS103	SLX20-55
9	SL20924	SLX20/SLX40/SLX45
	ADF25921	SLX25/SLX30/SLX50
	SL20940	SLX35/SLX55
10	DPT35004	SLX20-55
11	DPT20001	SLX20-35
	DPT45004	SLX40-55
12	DPP35105	SLX20-35
	DPP25104	SLX40-55
13	DPP35103	SLX20-35
	DPP45103	SLX40-55
14	DPP35104	SLX20-35
	DPP45104	SLX40-55
15	SL20935C	SLX20-55
16	SL20096D	SLX20-55
17	SL20936D	SLX20-55
18	DPD25073	SLX20-55 PROFI
19	SL20102A	SLX20-55 PROFI
	SL20092A	SLX20-55 LAMBDA
20	DK422	SLX20-55 PROFI
	DK423	SLX20-55 LAMBDA
21	DPD25030D	SLX20-55
22	DPV25502B	SLX20-55
23	DPD15008A	SLX20-55
24	DPA15024A	SLX20-55
25	DPD25017	SLX20-55
26	DPC25005A	SLX20-55
27	SL20034G	SLX20-35
	SL40917	SLX40-55
28	SL20036G	SLX20-35
	SL40918	SLX40-55
29	SL20950	SLX20-35
	SL40950	SLX40-55
30	SL2011C	SLX20-55
31	SL20931A	SLX20-55
32	SL20932A	SLX20-55
33	SL20928D	SLX20-55
34	SL20927D	SLX20-55
35	DPV15086	SLX20-55
36	DPV25107B	SLX20-55
37	SL20970A	SLX20-55
38	ADF25807A	SLX20-55
39	ADF25935A	SLX20-55
40	SL20068A	SLX20-55 PROFI
	DPV25203	SLX20-55 LAMBDA
41	DPV15924B	SLX20-55 PROFI
42	SL20098E	SLX20-55
43	DPD15206	SLX20-55
44	DPV25108A	SLX20-55

#	CODE	TYPE
45	DPV45035A	SLX20-55
46	TS091	SLX20-55
47	PEL0490	SLX20-55
48	DPV25803	SLX20-55
49	SP111	SLX20-55 PROFI
50	DPV25303	SLX20-55 PROFI
51	OT11	SLX20-55
52	DPD25059	SLX20-55
53	DPD25110	SLX20-55
54	DPD25029	SLX20-55
55	DPD25011	SLX20-55
56	TS106	SLX20-55
57	DPD25067A	SLX20-55
58	DPD25034	SLX20-55 PROFI
59	DPV15902A	SLX20-35
	DPV15928A	SLX40-55
60	DPV15416A	SLX20-55
61	TS094A	SLX20-55
62	DPD25016A	SLX20-35
	DPD75002B	SLX40-55
63	DPD25091	SLX20-55
64	DPD15030	SLX20-55 PROFI
	SL20062	SLX20-55 LAMBDA
65	OT19C	SLX20-55
66	AT46C	SLX20-55
67	SL20949	SLX20-35
	SL40949	SLX40-55
68	DPD25080	SLX20-35
	DPD40001	SLX40-55
69	DPD25001B	SLX20-55
70	DPV45040	SLX20-55
71	DPD25016D	SLX20-35
	DPD25202D	SLX40-55
72	DPA45900	SLX40-55
73	SL20929C	SLX20-35
	SL40915B	SLX40-55
74	DPA25924	SLX20-35
	SL40037C	SLX40-55
75	ADF25641	SLX20-55 LAMBDA
76	DPD25220	SLX20-55 LAMBDA
77	SL20107	SLX20-55 LAMBDA
78	SL20108	SLX20-55 LAMBDA
79	TH05A	SLX20-55 LAMBDA
80	TH06A	SLX20-55 LAMBDA
81	TS095A	SLX20-55 LAMBDA
82	DPV35382D	SLX20-35
	DPV45382D	SLX40-55
83	SL20055C	SLX20-55 LAMBDA
84	H30810	SLX20-55 LAMBDA
85	SL20128A	SLX20-55 LAMBDA
86	SL20130	SLX20-55 LAMBDA
87	DPD25216	SLX20-55 LAMBDA
88	SL20032	SLX20-55 LAMBDA
89	DPV25301A	SLX20-55 LAMBDA
90	SL20095A	SLX20-55 LAMBDA
91	SL20118A	SLX20-55 LAMBDA
92	SL20129	SLX20-55 LAMBDA
93	DPD25223	SLX20-55 LAMBDA
94	SL20919B	SLX20-55 LAMBDA

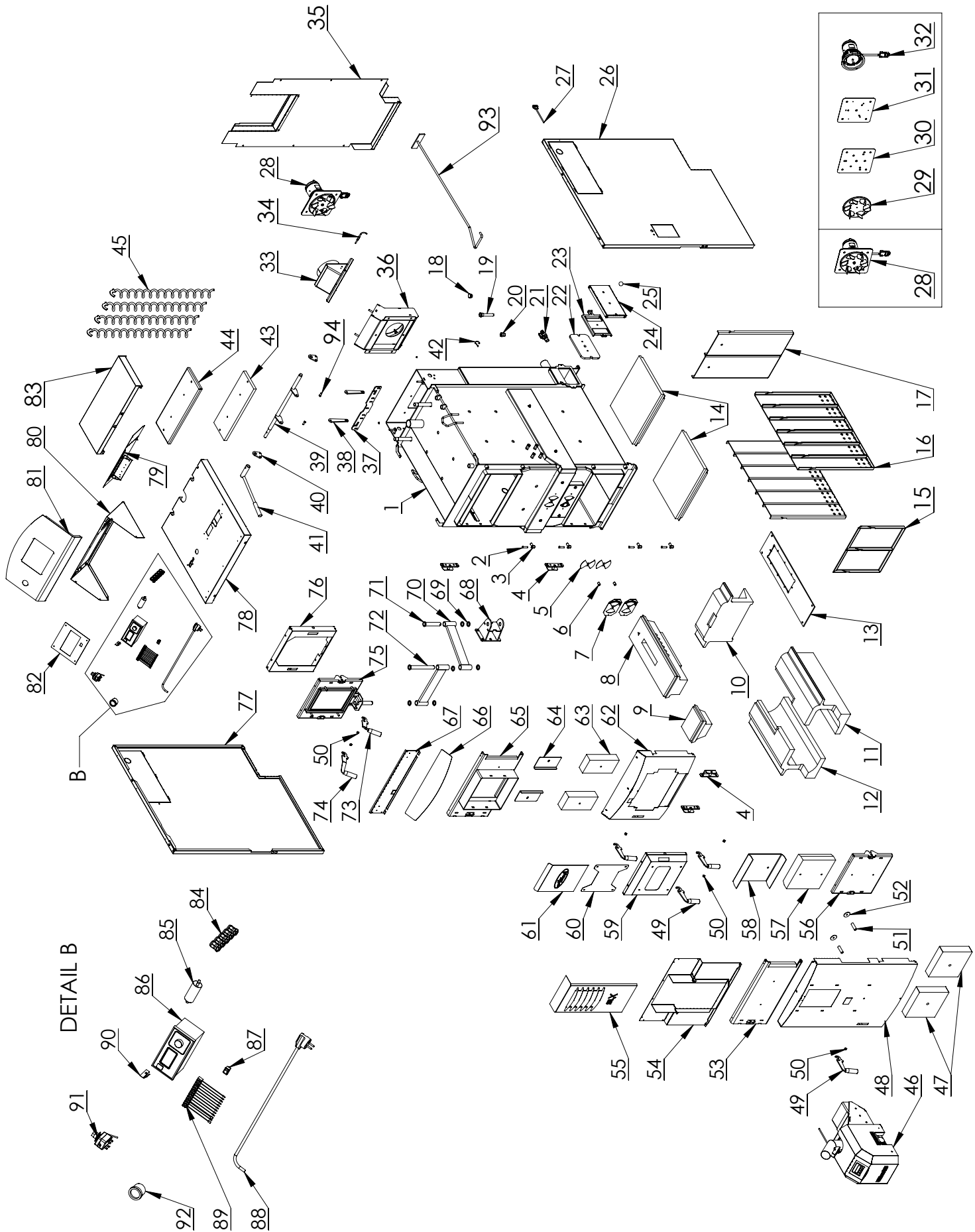

#	CODE	20SLXCP	25SLXCP	30SLXCP	35SLXCP
46	PELH30ACP	X	X	X	X
47	DPD25030D	X	X	X	X
48	SL20927D	X	X	X	X
49	ADF25807A	X	X	X	X
50	DPD15206	X	X	X	X
51	PEL30788	X	X	X	X
52	DPV15086	X	X	X	X
53	DPV25107B	X	X	X	X
54	SL20098E	X	X	X	X
55	SL20931A	X	X	X	X
56	DPV25818	X	X	X	X
57	DPV25821	X	X	X	X
58	DPV25817	X	X	X	X
59	DPA25049	X	X	X	X
60	DPA25050	X	X	X	X
61	DPA25914	X	X	X	X
62	SL20965A	X	X	X	X
63	DPD25606B	X	X	X	X
64	DPD25605A	X	X	X	X
65	SL20974	X	X	X	X
66	SL20932A	X	X	X	X
67	SL20097C	X	X	X	X
68	DPD25905	X	X	X	X
69	DPD25627	X	X	X	X
70	DPV25947	X	X	X	X
71	DPD25626A	X	X	X	X
72	DPD25629A	X	X	X	X
73	DPD25634A	X	X	X	X
74	DPD25632A	X	X	X	X
75	DPD25646B	X	X	X	X
76	DPA25917	X	X	X	X
77	SL20036G	X	X	X	X
78	SL20929C	X	X	X	X
79	SL20936D	X	X	X	X
80	SL20096D	X	X	X	X
81	SL20935C	X	X	X	X
82	SL20102B	X	X	X	X
83	DPA25924	X	X	X	X
84	TS094A	X	X	X	X
85	DPD25016A	X	X	X	X
86	DPD25073	X	X	X	X
87	DPD25135	X	X	X	X
88	TS091	X	X	X	X
89	DPD15030	X	X	X	X
90	DPD25034	X	X	X	X
91	OT19C	X	X	X	X
92	AT46C	X	X	X	X
93	DPC25005A	X	X	X	X
94	ADF25308	X	X	X	X

#	CODE	20SLXCP	25SLXCP	30SLXCP	35SLXCP
1	SL20901G	X	X	X	X
2	DPV25803	X	X	X	X
3	PEL0490	X	X	X	X
4	ADF25935A	X	X	X	X
5	SL20068A	X	X	X	X
6	DPV25303	X	X	X	X
7	SL20067C	X	X	X	X
8	DPT20001	X	X	X	X
	DPT35005	X	X	X	X
9	DPT35004	X	X	X	X
10	DPP35105	X	X	X	X
11	DPP35104	X	X	X	X
12	DPP35103	X	X	X	X
13	DPV35382D	X	X	X	X
14	SL20147A	X	X	X	X
15	SL20189	X	X	X	X
16	SL20022B	X	X	X	X
17	SL20186	X	X	X	X
18	DPD25029	X	X	X	X
19	DPD25011	X	X	X	X
20	OT11	X	X	X	X
21	TS103	X	X	X	X
22	DPD15008A	X	X	X	X
23	DPV25502B	X	X	X	X
24	DPA15024A	X	X	X	X
25	DPD25017	X	X	X	X
26	SL20034G	X	X	X	X
27	DPD25110	X	X	X	X
28	SL20949	X	X	X	X
29	DPD25080	X	X	X	X
30	DPD25001B	X	X	X	X
31	DPV45040	X	X	X	X
32	DPD25016D	X	X	X	X
33	SL20967	X	X	X	X
34	DPD25059	X	X	X	X
35	SL20916D	X	X	X	X
36	SL40907H	X	X	X	X
37	DPV15416A	X	X	X	X
38	DPD25067A	X	X	X	X
39	DPV15902A	X	X	X	X
40	DPV45035A	X	X	X	X
41	DPV15924A	X	X	X	X
42	TS106	X	X	X	X
43	SL20040B	X	X	X	X
44	SL20043D	X	X	X	X
	SL20924	X	X	X	X
45	ADF25921	X	X	X	X
	SL20940	X	X	X	X

#	CODE	#	CODE	#	CODE	#	CODE	#	CODE	#	CODE	#	CODE	#	CODE	#	CODE	#	CODE	#	CODE	#	CODE	#	CODE	#	CODE
1	PEL30100A	9	PEL982	17	PEL0175	25	PEL30713	33	OT19C	41	TS118L	49	H30808	57	PELH30Plus												
2	PEL994	10	PEL983	18	PEL0140A	26	PEL30715	34	OT19C	42	PEL30772	50	H30820	58	PEL30744												
3	PEL068	11	PEL0180	19	PEL914A	27	PEL30714	35	DPD25009A	43	PEL30770	51	H30809	59	SP139												
4	PEL980	12	PEL0179	20	PEL915A	28	PEL30707	36	DPD25010	44	PEL30718	52	PEL30723A	60	PEL30980C												
5	PEL0107C	13	PEL30753	21	PEL30700	29	PEL30761	37	TH23A	45	PEL30720	53	PEL30725	61	PEL0182A												
6	PEL945B	14	PEL30758	22	PEL30717	30	PEL30710	38	TH05	46	PEL98B	54	PEL30730A	62	PEL30756												
7	PEL937	15	PEL991	23	PEL30716	31	PEL30703	39	TH06B	47	DPD25030U	55	PEL30738	63	PEL30757												
8	PEL981	16	PEL30208B	24	PEL943	32	DPD25008A	40	PEL005B	48	PEL098	56	H30814	64	DPV95086												

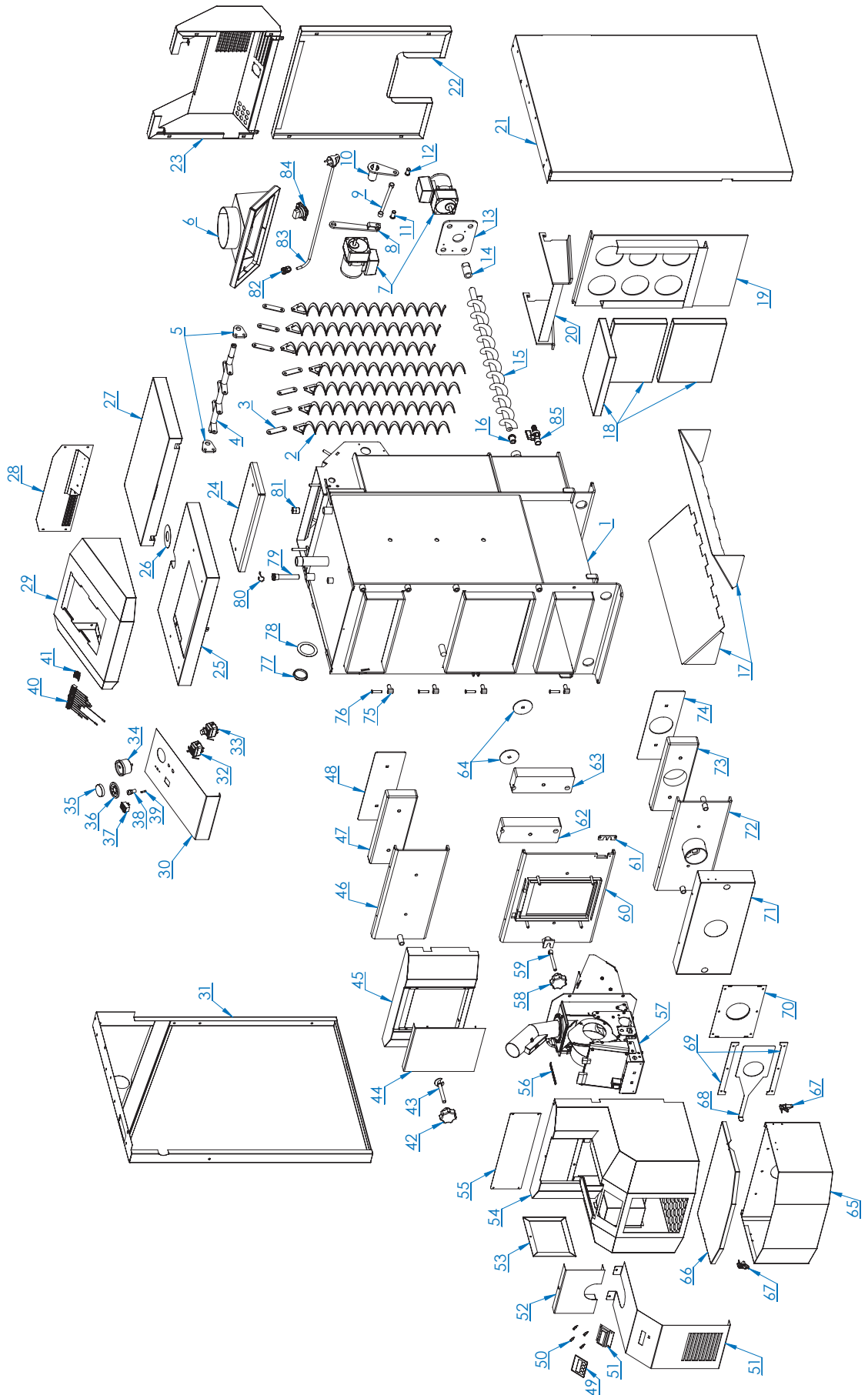

#	CODE
100	PELH30900A
101	H30921C
102	H30930A
103	H30920B
104	H30940A
105	H30001
106	H30009A
107	PR15
108	H30952
109	H30012A
110	H30982
111	H30961B
112	PELH30851
113	PELH30800A
114	PELH30807B
115	TS215
116	H30018
117	H30807
118	HP30900
119	H30806B
120	PELH30830A
121	PELH30843
122	H30803
123	H30118B
124	H30014
125	H30003A
126	H30804
127	H30980
128	H30008A
129	TS118L
130	H30813A
131	H30002
132	ADF25640

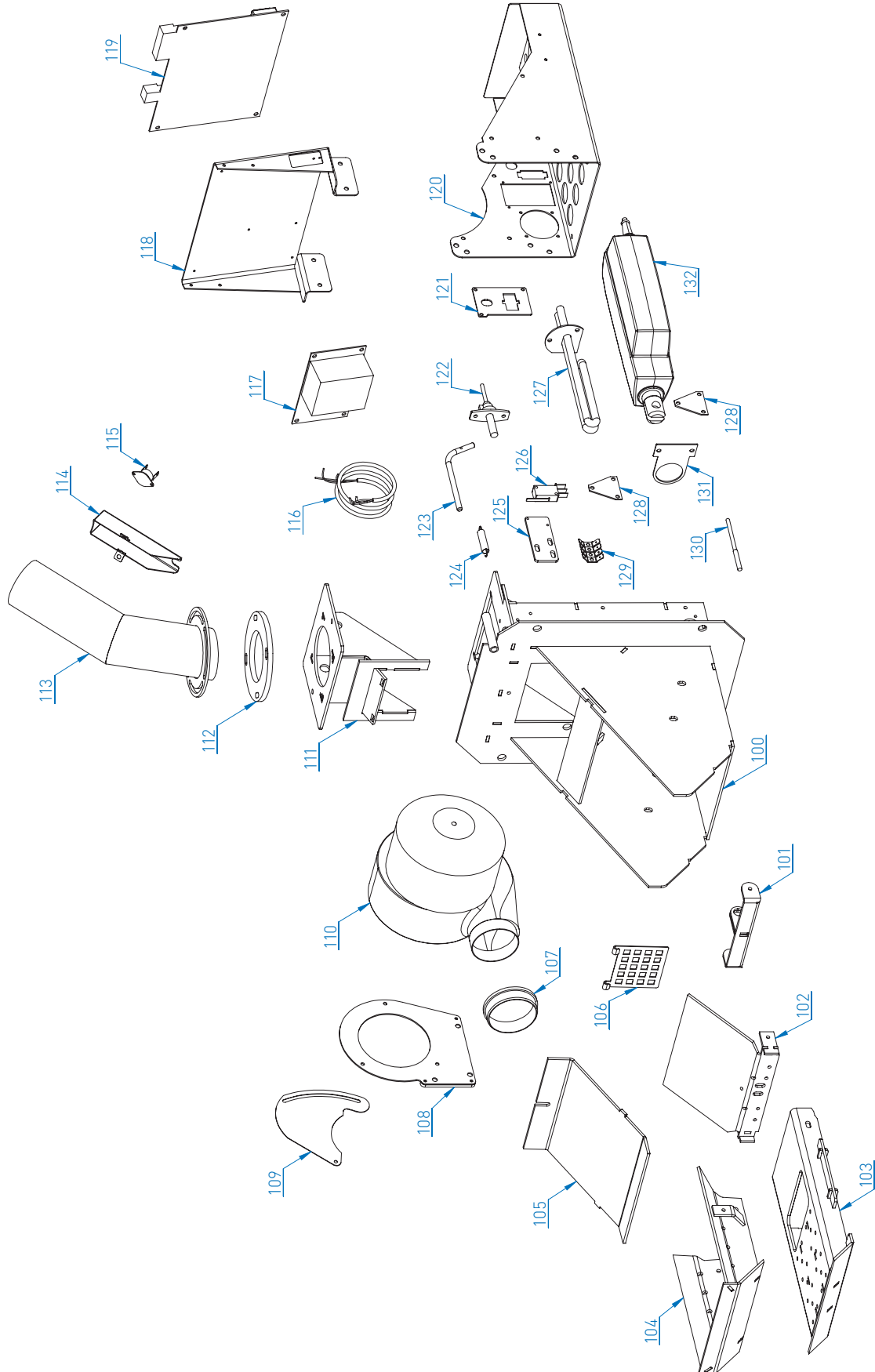

#	CODE
61	PEL30729A
62	PEL098C
63	PEL30928
64	PEL30723B
65	PEL30774
66	H30808
67	H30820
68	H30809
69	DPV15086
70	PEL0182A
71	PEL30208B
72	PEL30926
73	PEL30927
74	SP139

#	CODE
1	PEL30100A
2	PEL915A
3	PEL991
4	PEL0175
5	PEL0140A
6	PEL914A
7	PEL30758
8	PEL0180
9	PEL802
10	PEL30700B
11	PEL30753
12	PEL937
13	PEL981A
14	PEL983
15	TS103
16	PEL994
17	PEL0179
18	PEL30717A
19	PEL068
20	DPV45035A
21	PEL980A
22	PEL30716A
23	PEL945B
24	TS091
25	TH31
26	PEL943
27	OT11
28	TS094A
29	DPD25011
30	TS106
31	PEL30713A
32	PEL30759A
33	PEL30711A
34	PEL30707A
35	PEL30714A
36	DPD25009A
37	DPD25010
38	OT19C
39	DPD25008A
40	TH23A
41	TH05A
42	TS099A
43	PEL005B
44	PEL30703B
45	PEL30787
46	PEL30718A
47	PEL30720A
48	PEL098
49	DPD25030U
50	PEL0220
51	PEL30730B
52	PEL30770
53	PEL30772
54	PEL30738A
55	PEL30756
56	PELH30PLUS
57	DPD25030UC
58	PEL30740B
59	PEL30933
60	PEL981

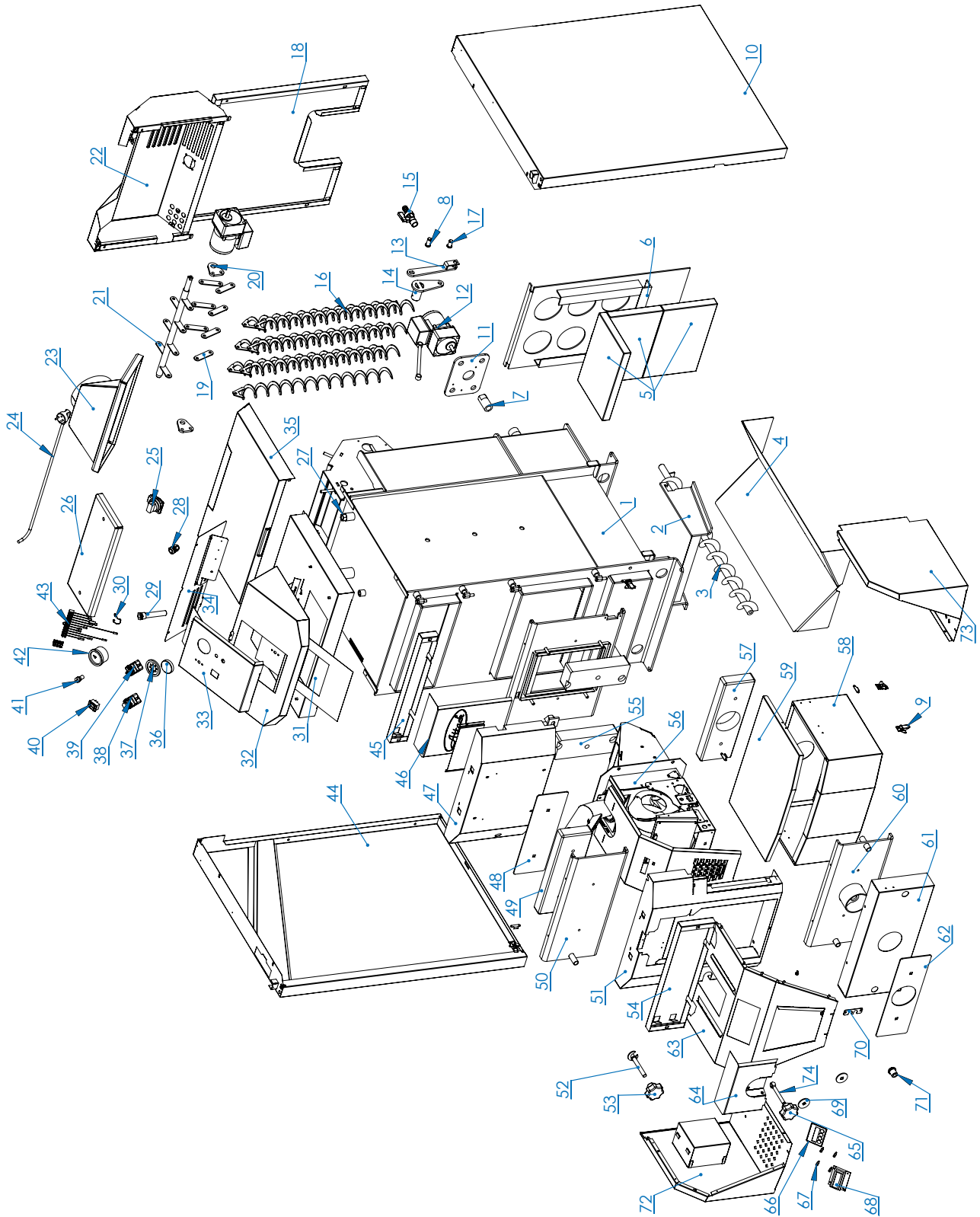

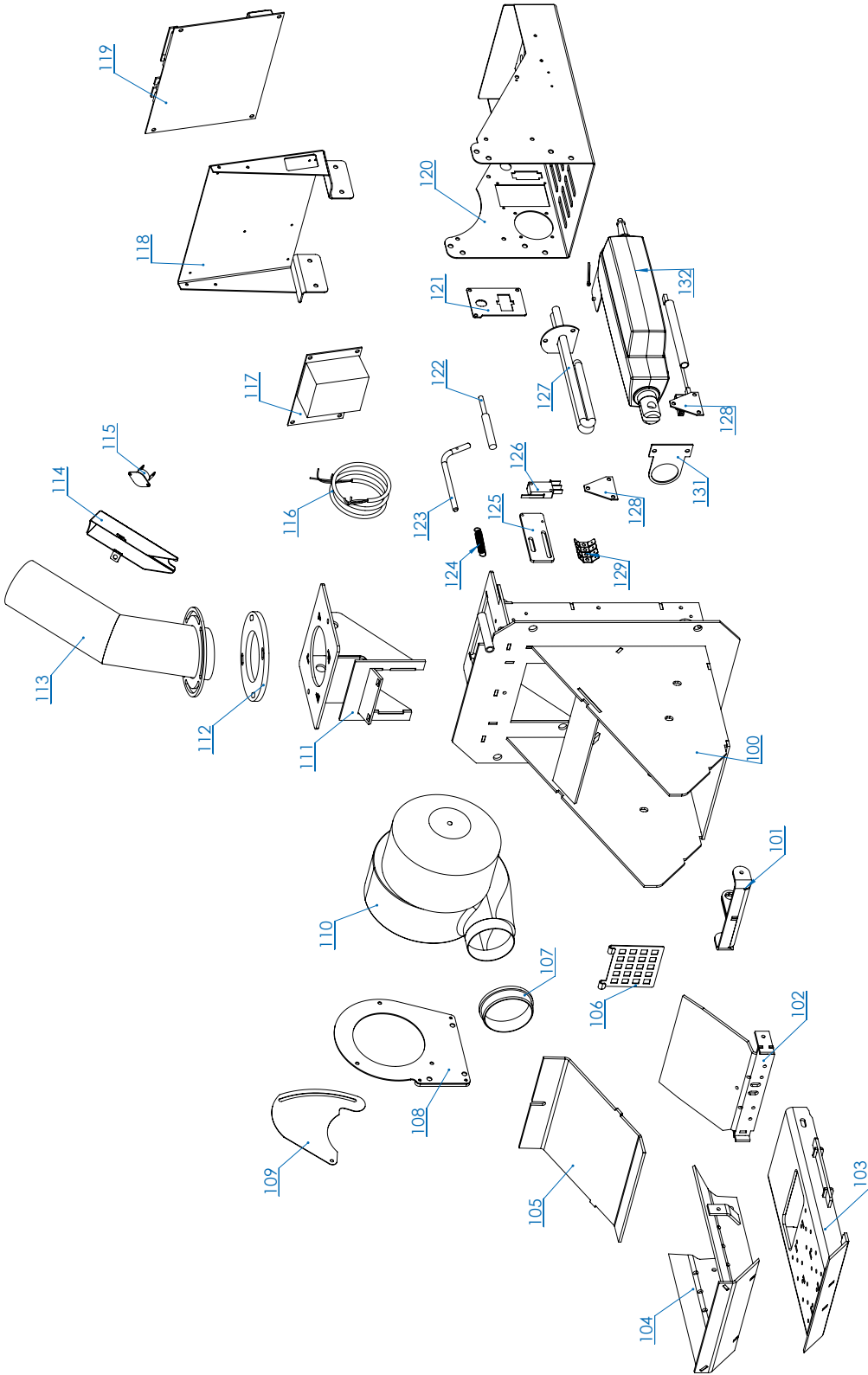

#	CODE
28	PELH30843
29	PELH30830A
30	HP30900
31	H30806B
32	TS215B
33	H30982

#	CODE
19	TS131
20	ADF25640
21	H30118B
22	H30014
23	PELH30811
24	H30980
25	H30803
26	H30018
27	H30807

#	CODE
10	H30012A
11	H30961B
12	PELH30851
13	PELH30800A
14	PELH30807B
15	H30008A
16	H30002
17	H30003A
18	H30804

#	CODE
1	H30920B
2	H30940A
3	H30001
4	H30930A
5	H30921C
6	H30009A
7	PR15
8	PELH30900A
9	H30952

#	CODE	#	CODE
1	PEL30100A	41	PEL30717B
2	PELH30Plus	42	PEL30716B
3	H30813A	43	PEL30792
4	PEL994	44	PEL30729A
5	PEL943	45	PEL802
6	PEL980A	46	PEL30740B
7	PEL983	47	PEL30933
8	PEL982A	48	PEL30730C
9	PEL981B	49	PEL30723B
10	PEL068	50	PEL30928A
11	DPV45035A	51	PEL30738A
12	PEL937	52	PEL30727C
13	PEL945B	53	PEL30720B
14	PEL0140A	54	PEL30777
15	PEL915A	55	PEL30718A
16	PEL914A	56	PEL30787
17	PEL0175	57	OT11
18	PEL30753	58	DPD25011
19	PEL30758	59	TS106
20	PEL991	60	TS094A
21	PEL0490	61	TS091
22	PEL988	62	TS103
23	DPD25030U	63	PEL30788
24	PEL098	64	PEL30936
25	PEL30770	65	PEL30935
26	PEL30772	66	TH06B
27	PEL981	67	OT19C
28	DPD25030UC	68	TS095A
29	PEL098C	69	TH05A
30	PEL30208B	70	TS099A
31	SP139	71	PEL30833
32	PEL30744	72	PEL30823A
33	PEL30756	73	PEL30832
34	PEL30757	74	TH31
35	DPV15086	75	PEL30839
36	PEL0182A	76	PEL30840
37	PEL30980C	77	PEL30826
38	PEL30703D	78	PEL30824
39	PEL30700C	79	PEL30827
40	PEL30714A	80	PEL30822

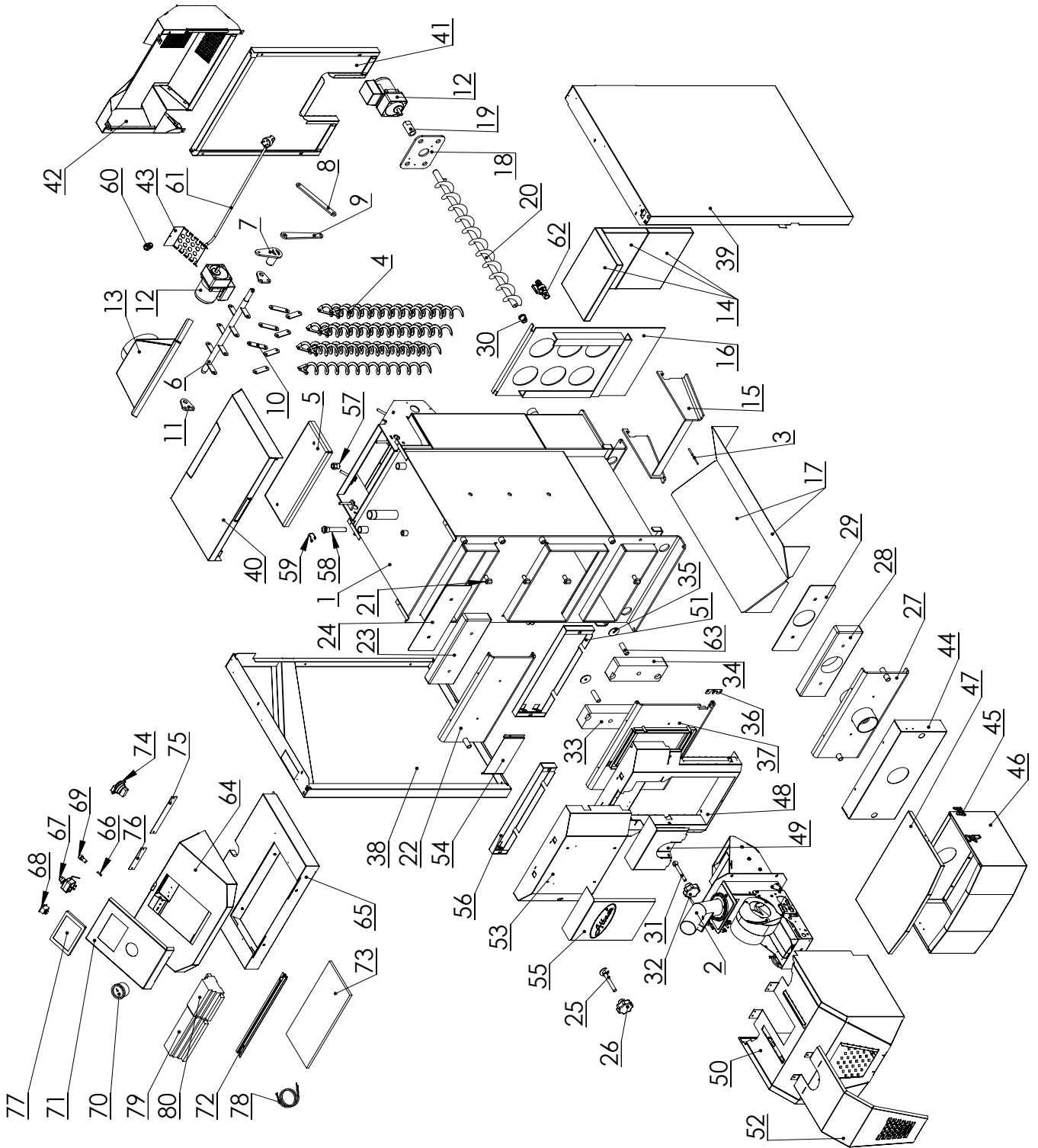

#	CODE
1	PELH30900B
2	H30920B
3	H30921C
4	H30930A
5	H30940B
6	PELH30830A
7	H30961B
8	H30980
9	H30982
10	H30952
11	H30001
12	H30002
13	H30003A
14	H30009A
15	H30118D
16	H30012A
17	H30014
18	H30803
19	H30804
20	ADF25640
21	PR15
22	PEL30825
23	H30008A
24	PELH30851
25	PELH30800A
26	PELH30843A
27	PELH30807B
28	PELH30811
29	TS215B

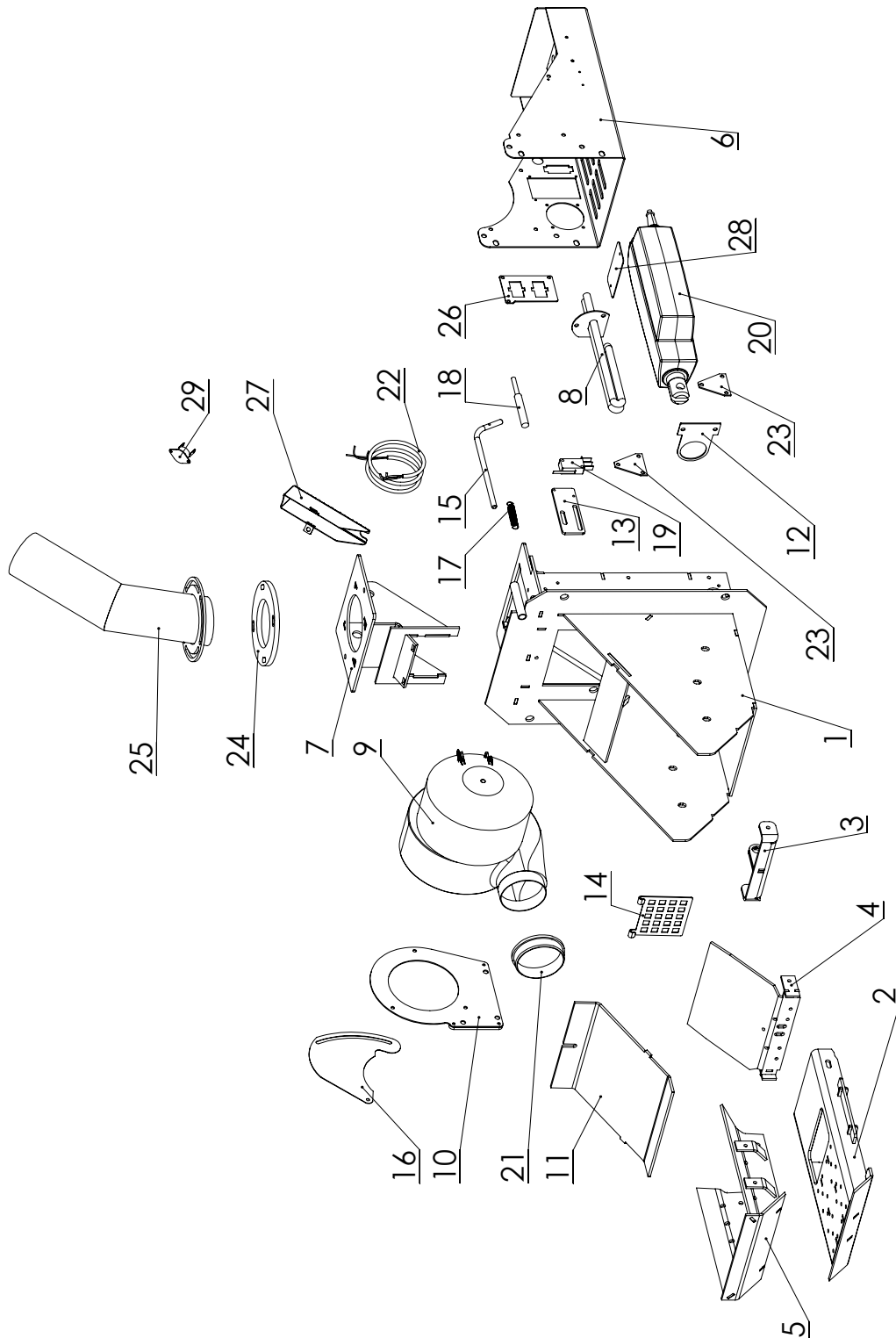

#	CODE	#	CODE
1	PEL30100A	41	PEL30717B
2	PELH30Plus	42	PEL30716B
3	H30813A	43	PEL30792
4	PEL994	44	PEL30729A
5	PEL943	45	PEL802
6	PEL980A	46	PEL30740B
7	PEL983	47	PEL30933
8	PEL982A	48	PEL30730C
9	PEL981B	49	PEL30723C
10	PEL068	50	PEL30928A
11	DPV45035A	51	PEL30738A
12	PEL937	52	PEL30727C
13	PEL945B	53	PEL30720B
14	PEL0140A	54	PEL30777
15	PEL915A	55	PEL30718A
16	PEL914A	56	PEL30787
17	PEL0175	57	OT11
18	PEL30753	58	DPD25011
19	PEL30758	59	TS106
20	PEL991	60	TS094A
21	PEL0490	61	TS091
22	PEL988	62	TS103
23	DPD25030U	63	PEL30788
24	PEL098	64	PEL30936
25	PEL30770	65	PEL30935
26	PEL30772	66	TH06B
27	PEL981	67	OT19C
28	DPD25030UC	68	TS095A
29	PEL098C	69	TH05A
30	PEL30208B	70	TS099A
31	SP139	71	PEL30833
32	PEL30744	72	PEL30823A
33	PEL30756	73	PEL30832
34	PEL30757	74	TH31
35	DPV15086	75	PEL30839
36	PEL0182A	76	PEL30840
37	PEL30980C	77	PEL30826
38	PEL30703D	78	PEL30824A
39	PEL30700C	79	PEL30827
40	PEL30714A	80	PEL30835

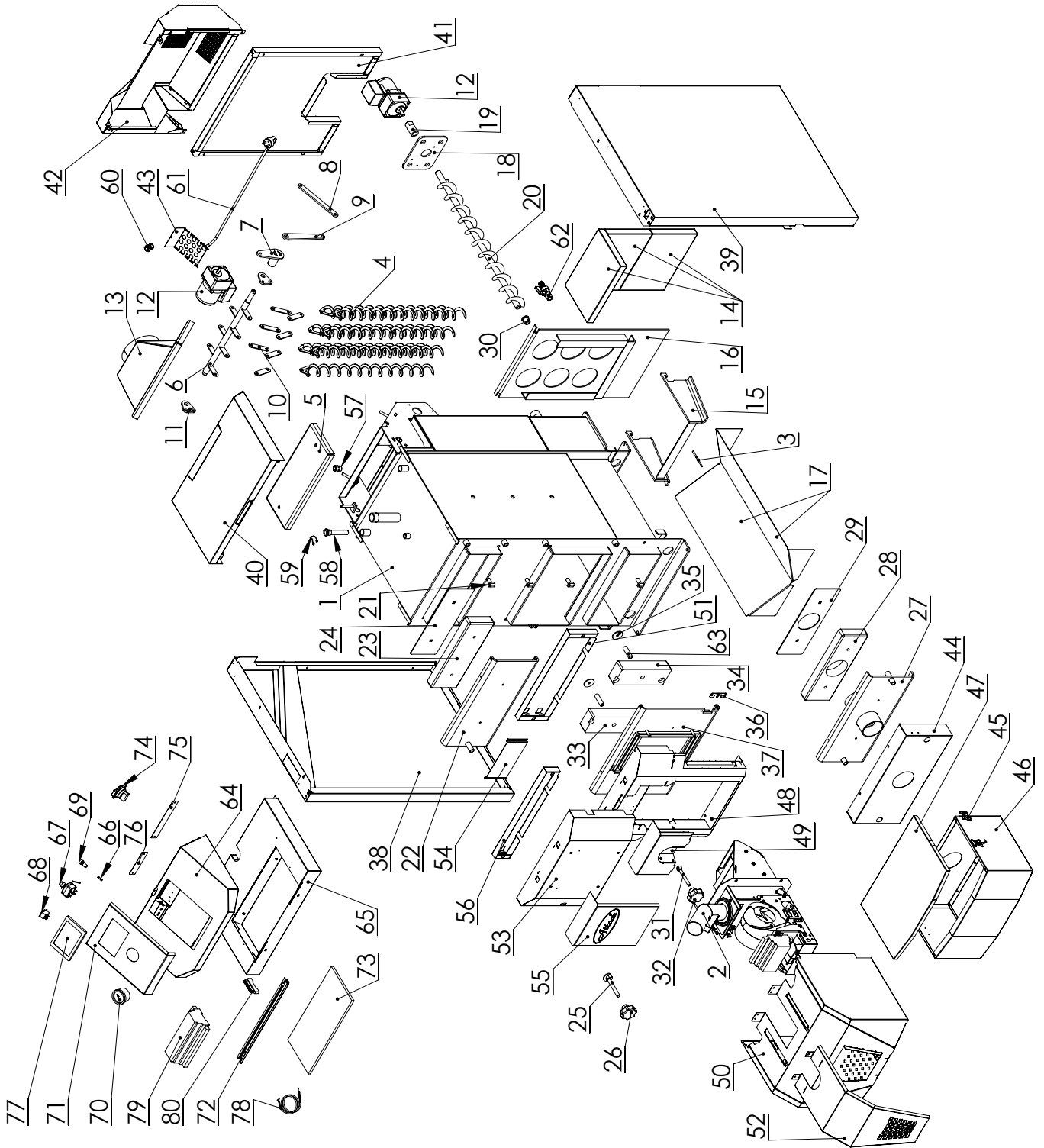

#	CODE
1	PELH30900B
2	H30920B
3	H30921C
4	H30930A
5	H30940B
6	PELH30830A
7	H30961B
8	H30980
9	H30982
10	H30952
11	H30001
12	H30002
13	H30003A
14	H30009A
15	H30118D
16	H30012A
17	H30014
18	H30803
19	H30804
20	ADF25640
21	PR15
22	PEL30825A
23	H30008A
24	PELH30851
25	PELH30800A
26	PELH30843A
27	PELH30807C
28	PELH30811
29	TS215B
30	PEL30822
31	PEL30836
32	PEL30838

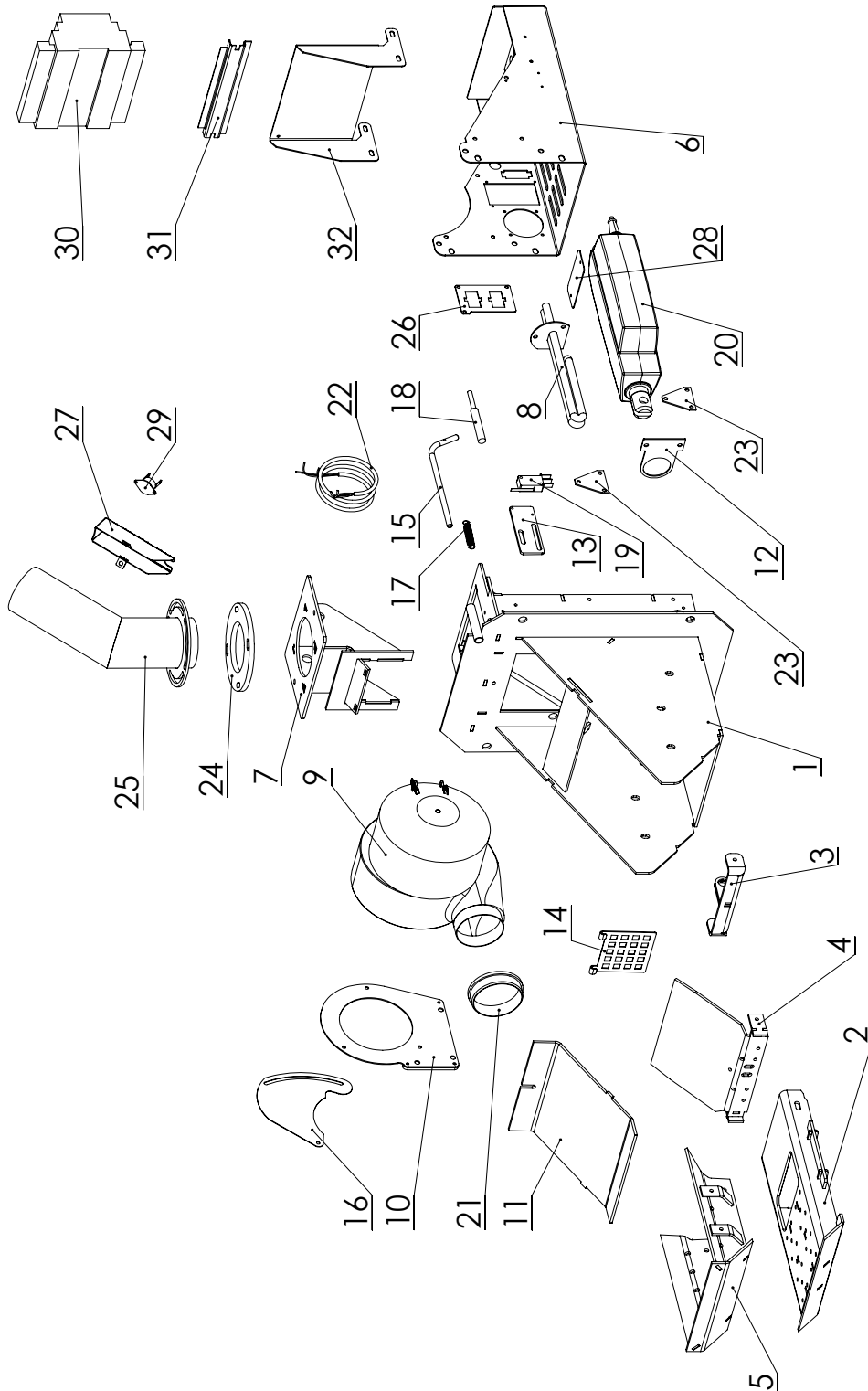

#	CODE
1	ADF25484B
2	ADF25952C
3	ADF25445A
4	ADF25828
5	ADF25825
6	ADF25970B
7	ADF25506B
8	ADF25570
9	ADF25407A
10	ADF25969D
11	ADF25441C
12	ADF25943F
13	ADF25488
14	FDA304
15	DPD25221
16	ADF25959D
17	ADF25580A
18	ADF25566A
19	ADF25444E
20	ADF25599A

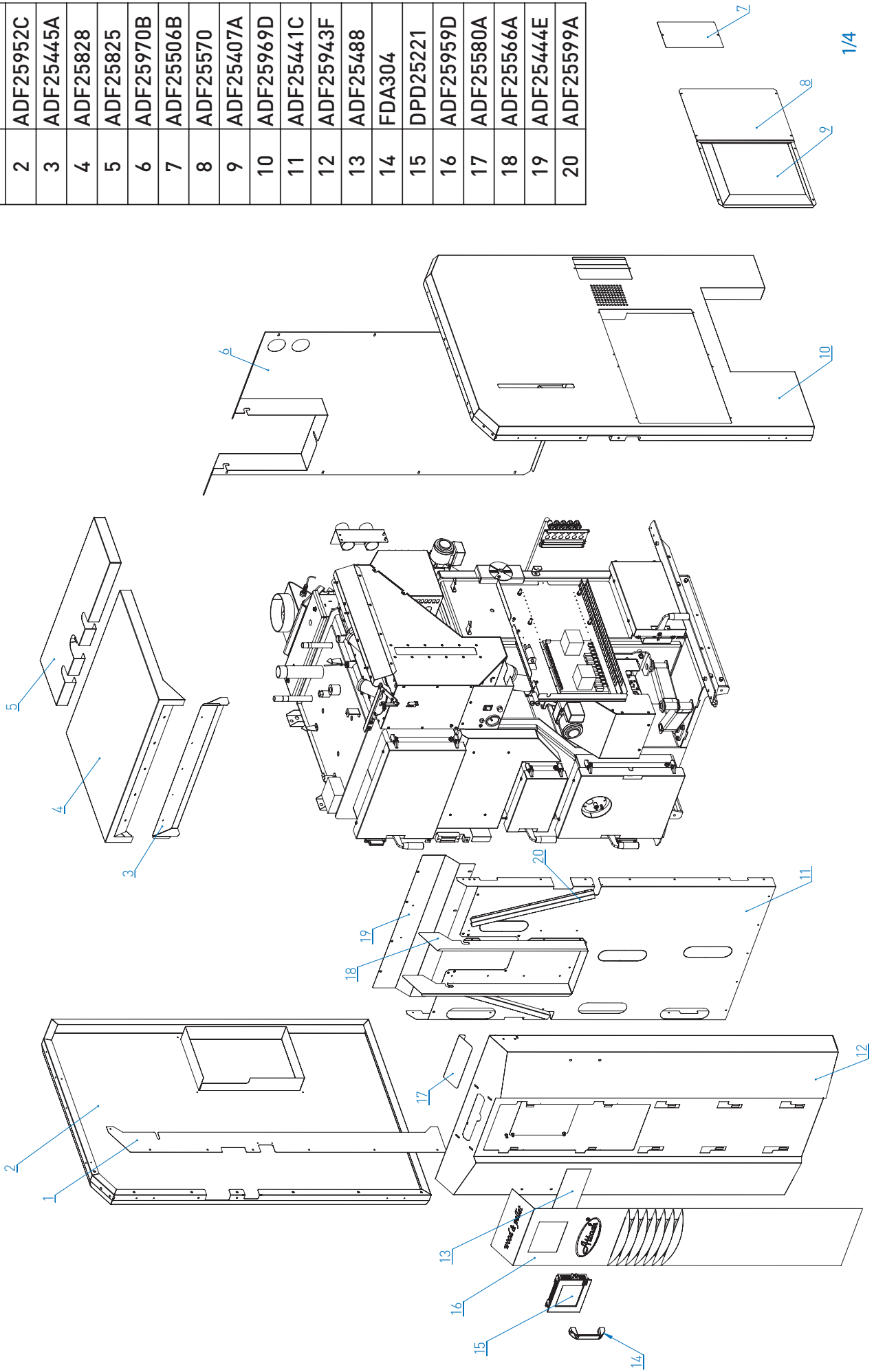

#	CODE	#	CODE	#	CODE	#	CODE	#	CODE	#	CODE	#	CODE	#	CODE	#	CODE	#	CODE
30	ADF25526A	39	ADF25585	49	ADF25524A	59	ADF25905	69	ADF25844	79	DPD25202	90	DPD25202	101	ADF25610	122	ADF25477C		
31	ADF25301	40	ADF25808	50	ADF25845	60	ADF25901	70	ADF25984	80	DPD25202H	91	DPD25202E	102	ADF25460C	123	ADF25413D		
32	ADF25299D	41	ADF25344	51	ADF25220A	61	ADF25486	71	ADF25188	81	ADF25830	92	ADF25632	103	ADF25597	124	PEL937		
33	ADF25982A	42	ADF25955A	52	ADF25803	62	ADF25307A	72	ADF25189	82	ADF25618	93	ADF25308	104	ADF25308	125	ADF25924		
34	ADF25111	43	SP199	53	ADF25846	63	ADF25303A	73	DPD25059	83	ADF25496	94	RE221	105	ADF25102	126	ADF25342D		
35	ADF25806	44	ADF25091	54	ADF25350	64	ADF25312B	74	ADF25816	84	ADF25539A	95	ADF25613	106	ADF25101	127	ADF25439C		
36	SP161	45	ADF25304A	55	PELH30ADF	65	HV200	75	ADF25223	85	DPV25103A	96	ADF25847	107	ADF25842	128	ADF25582		
37	ADF25820	46	ADF25095	56	ADF25813	66	ADF25289	76	DPD45909B	86	ADF25819A	97	ADF25614	108	ADF25918	129	ADF25829		
38	DPV25303	47	ADF25309	57	ADF25985	67	ADF25464	77	DPD25001B	87	ADF25980	98	ADF25528A	109	DPD25065	130	ADF25579		
		48	ADF25096	58	ADF25904A	68	ADF25478	78	DPV25222	88	ADF25542	99	ADF25223	110	DPV45035A	131	ADF25440D		
										89	ADF25540C	100	ADF25838	111	ADF25544	132	ADF25413D		
														112	SP146	133	ADF25343D		
														113	ADF25917	134	ADF25348C		
														114	PEL0180	135	ADF25345		
														115	SP154	136	ADF25449A		
														116	ADF25921	137	ADF25801A		
														117	PEL983	138	TH05A		
														118	ADF25541	139	H30804		
														119	TS099A	140	ADF25543		
														120	OT19C	141	ADF25972A		
														121	TS095A	142	ADF25602		

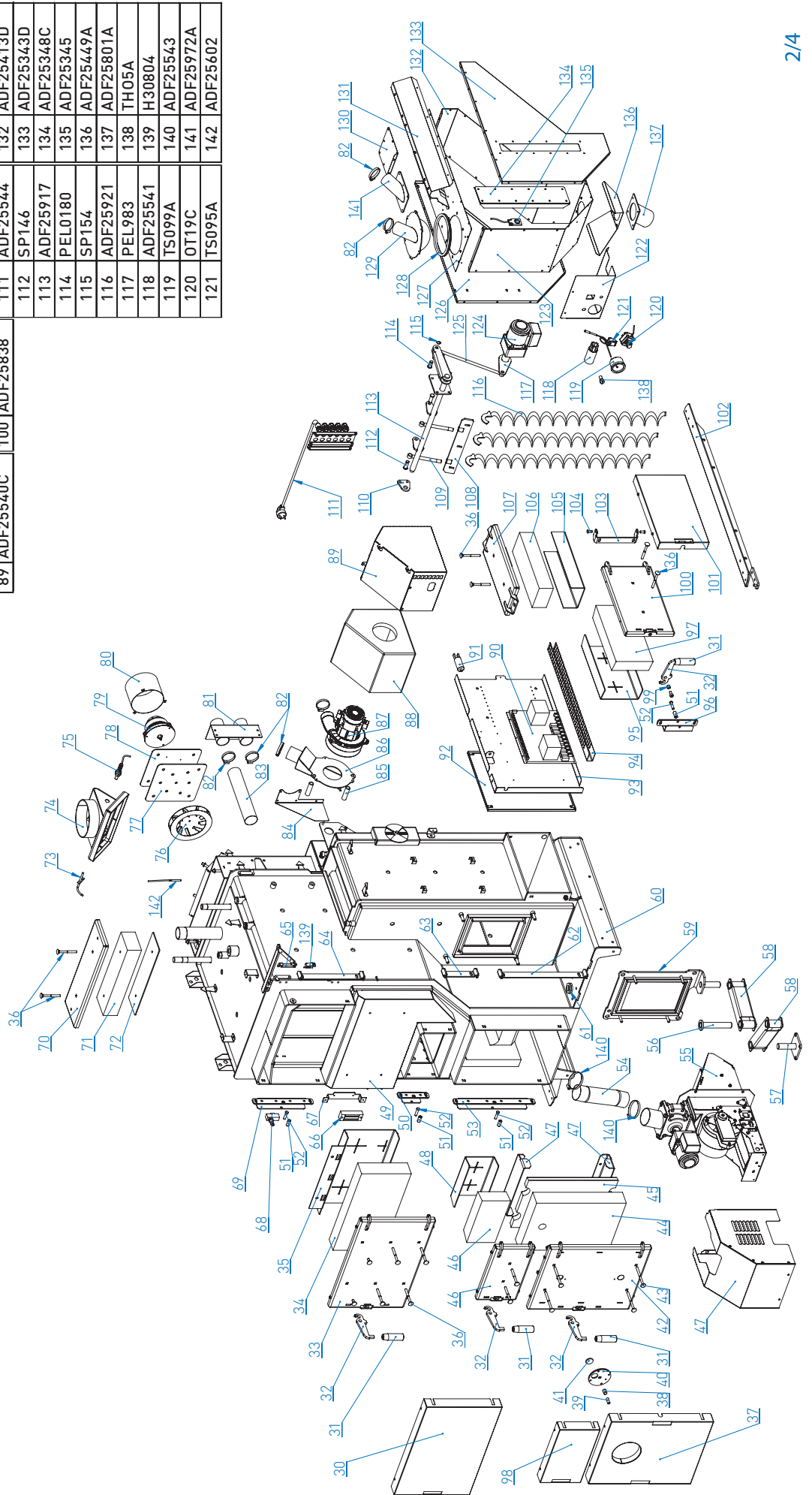

#	CODE
150	ADF25848
151	ADF25128C
152	ADF25851
153	ADF25850
154	ADF25131A
155	ADF25130A
156	ADF25104A
157	ADF25849
158	ADF25036
159	ADF25592
160	ADF25038B
161	ADF25037B
162	ADF25628
163	ADF25067B
164	ADF25066B
165	ADF25086A
166	ADF25087A
167	ADF25084
168	ADF25083B
169	ADF25841

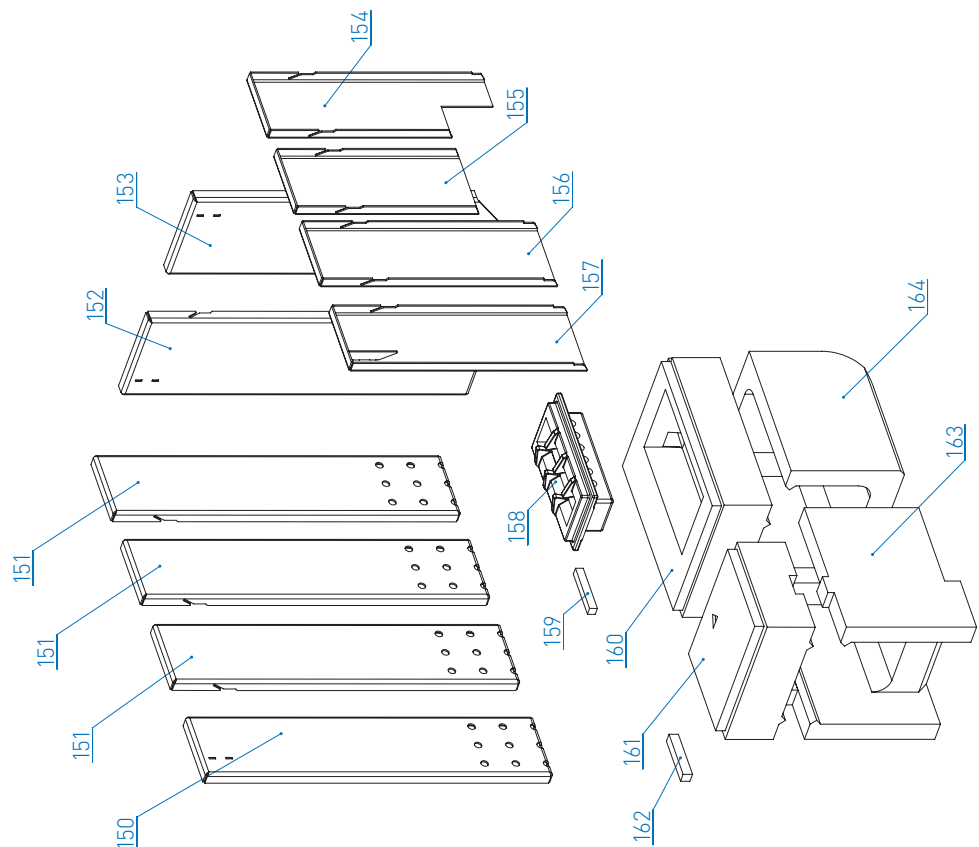
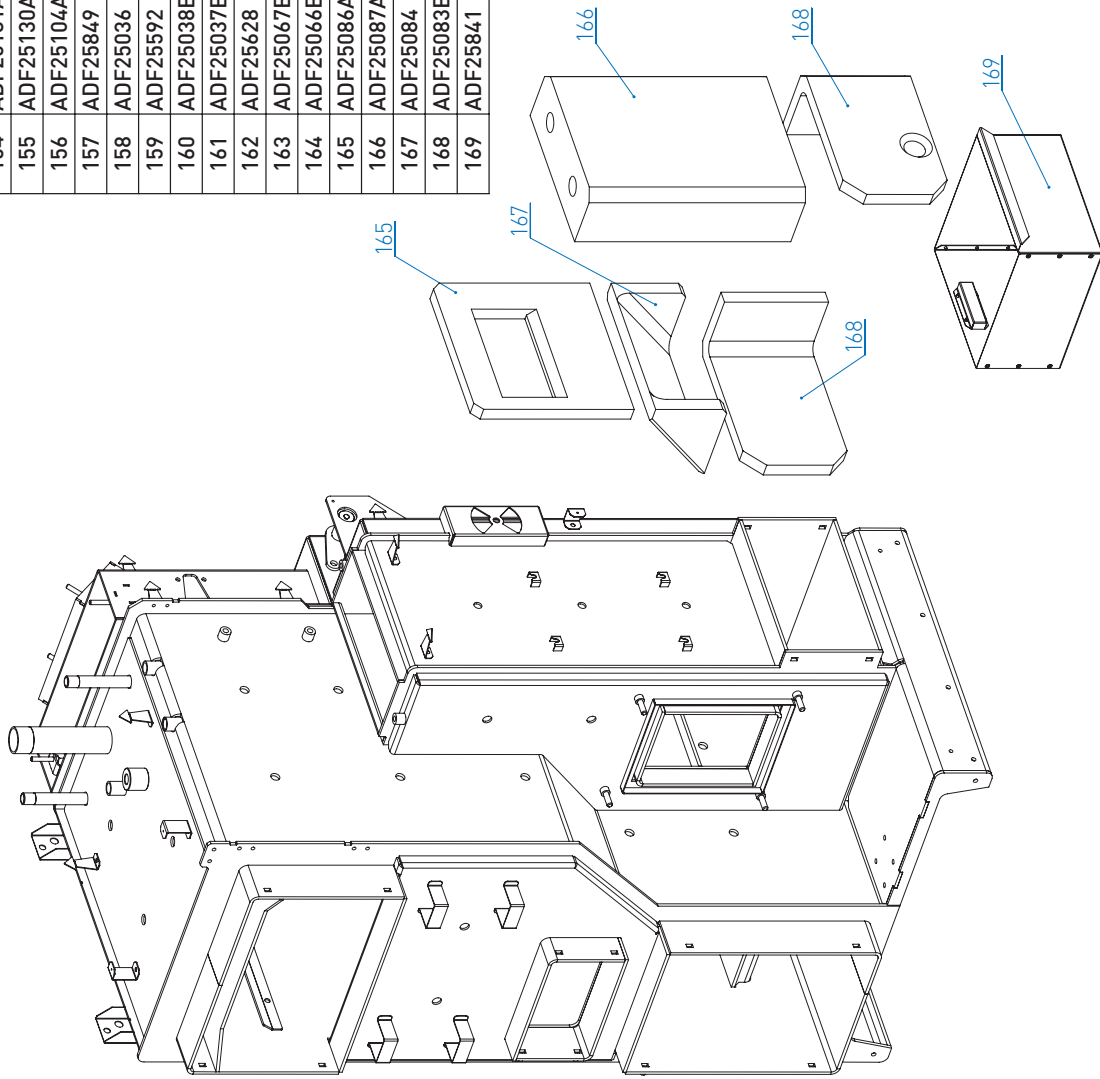

#	CODE	#	CODE
180	ADF25640	197	H30930A
181	H30980	198	H30001
182	PELH30830A	199	PELH30900A
183	ADF25386	200	TS118L
184	H30002	201	H30803
185	H30008A	202	H30009A
186	H30982	203	H30961B
187	PR15	204	ADF25802A
188	ADF25812	205	ADF25230
189	DPV25203	206	ADF25996C
190	ADF25395	207	ADF25459
191	DPV25304	208	DPV25803
192	ADF25063	209	PEL937
193	DPD25216	210	ADF25518
194	DPV25303	211	ADF25608
195	H30940A	212	H30921C
196	H30920B		

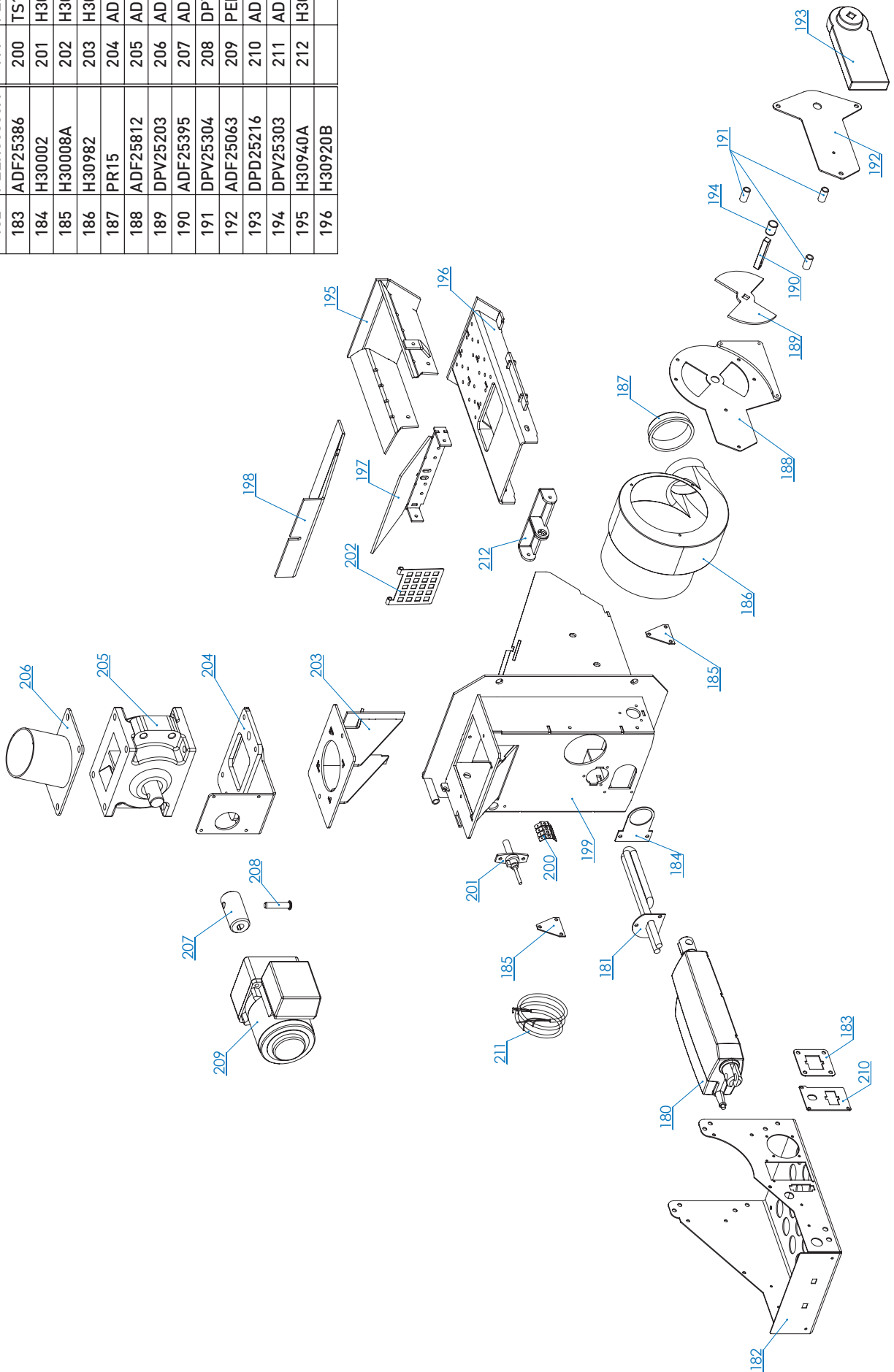

#	CODE
1	PEL801
2	ADF25641
3	ADF2566C
4	WPA25033
5	WPA25907
6	WPA25906
7	ADF25834C
8	ADF25444G
9	HV200
10	ADF25504A
11	ADF25721
12	WPA25022
13	ADF25445C
14	ADF25484D
15	WPA25016
16	WPA25902
17	WPA25903
18	WPA25904
19	WPA25905
20	ADF25830
21	WPA25901
22	WPA25015
23	WPA25014
24	ADF25593A

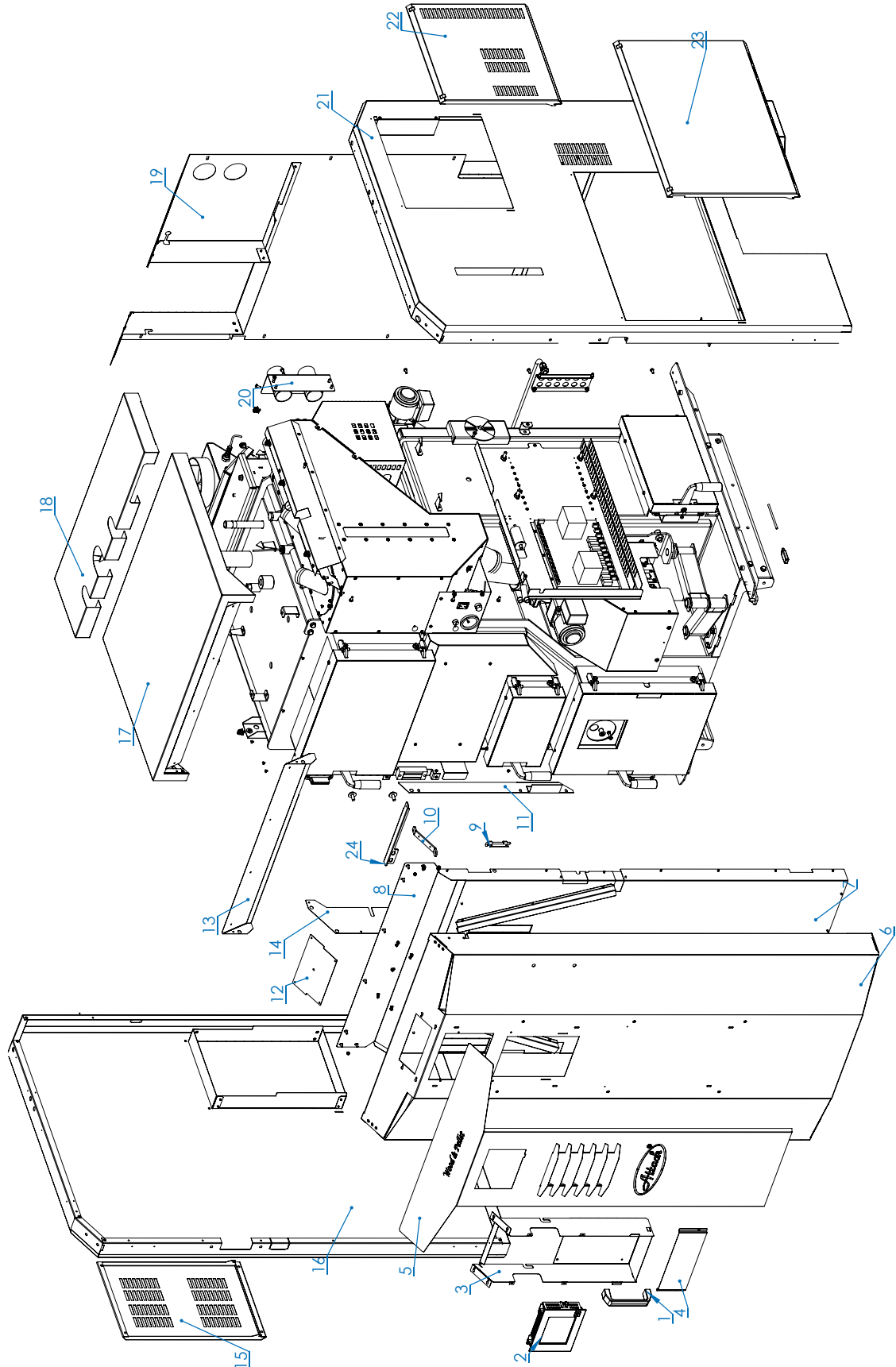

#	CODE
85	ADF25345
86	TS094
87	ADF25853
88	DPD25220
89	WP25014
90	ADF25613
91	ADF25614
92	ADF25838
93	WPA25030
94	DPD25224
95	ADF25600
96	ADF25460D
97	ADF25905
98	ADF25486
99	ADF25813
100	ADF25904A
101	ADF25985
102	ADF25308
103	ADF25307A
104	ADF25465
105	ADF25303A
106	ADF25096
107	ADF25095
108	ADF25983A
109	WPA25029
110	ADF25309
111	ADF25304A
112	ADF25091
113	ADF25955A
114	WPA25031
115	WPA25032
116	ADF25808
117	DPV25303
118	DPV25304
119	ADF25390B
120	PELH30ADF
121	DPD25220
141	TS103

#	CODE
25	TS099A
26	TH05A
27	TS138
28	OT19C
29	DPD75002B
30	ADF25541
31	ADF25807
32	WPA25028
33	ADF25111
34	ADF25806
35	ADF25982A
36	DPD25216
37	ADF25063
38	ADF25515
39	DPV25203
40	DPV25304
41	ADF25134A
42	DPV25301A
43	ADF25465
44	ADF25490
45	ADF25289
46	ADF25312B
47	ADF25464
48	ADF25223
49	OT11
50	ADF25602
51	DPD25011
52	DPD25029
53	ADF25842
54	ADF25101
55	ADF25102
56	ADF25984
57	ADF25188
58	ADF25189
59	DPD25059
60	ADF25816
61	DPD25223
62	DPV45035A
63	DPD45909B
64	DPD25001B
65	DPV45040
66	DPD25202D
67	DPA45011
68	ADF25917
69	DPD25065
70	ADF25918
71	ADF25830
72	ADF25918
73	ADF25544
74	ADF25924
75	PEL983
76	PEL937
77	ADF25539A
78	ADF25819A
79	ADF25980
80	ADF25831
81	ADF25618
82	ADF25496
83	ADF25961D
84	ADF25350

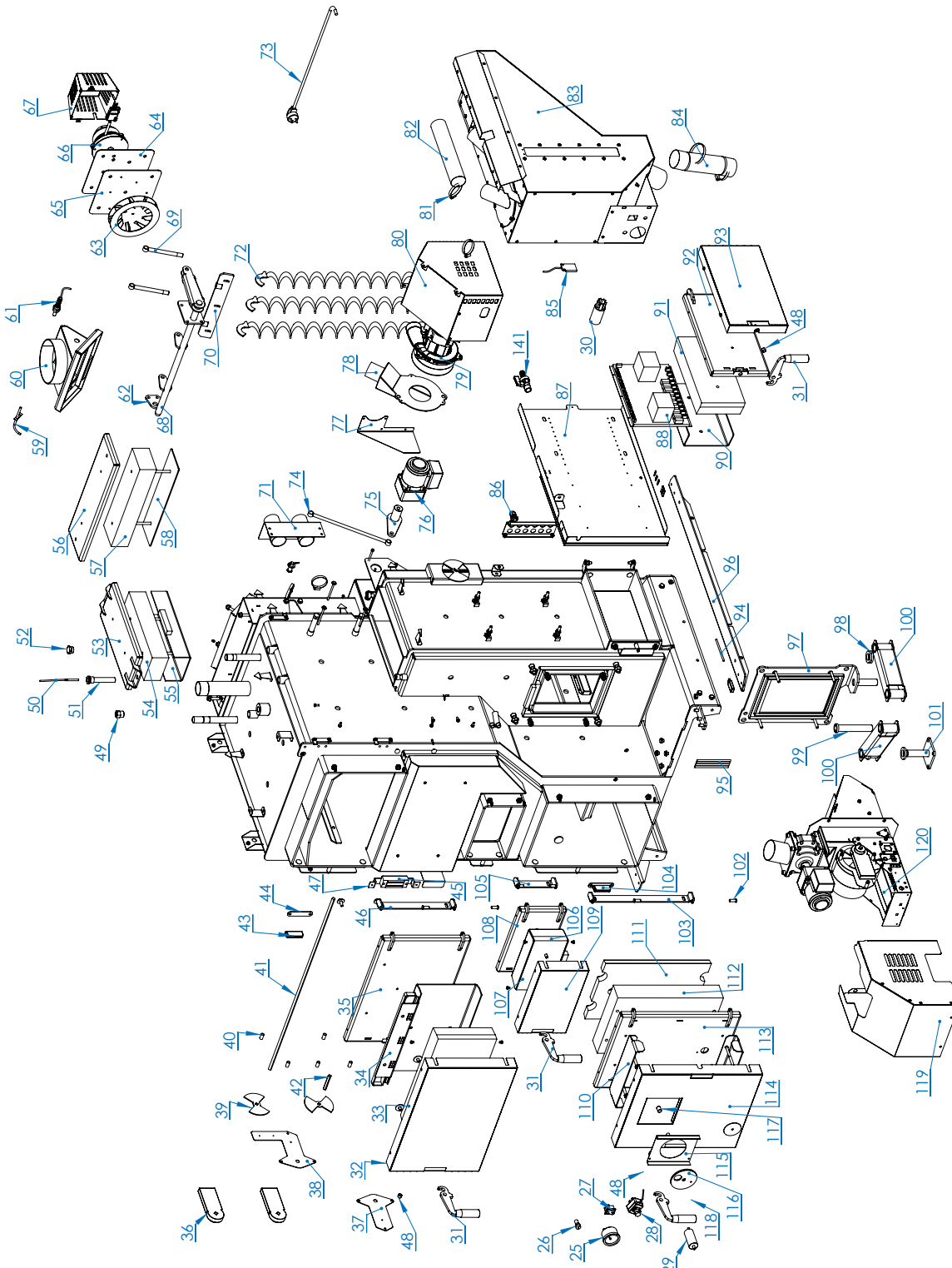

#	CODE
122	ADF25848
123	ADF25128C
124	ADF25851
125	ADF25850
126	ADF25849
127	ADF25104A
128	ADF25130A
129	ADF25131A
130	ADF25038B
131	ADF25037B
132	ADF25067B
133	ADF25066B
134	ADF25086A
135	ADF25087A
136	ADF25083B
137	ADF25841
138	ADF25036
139	ADF25084

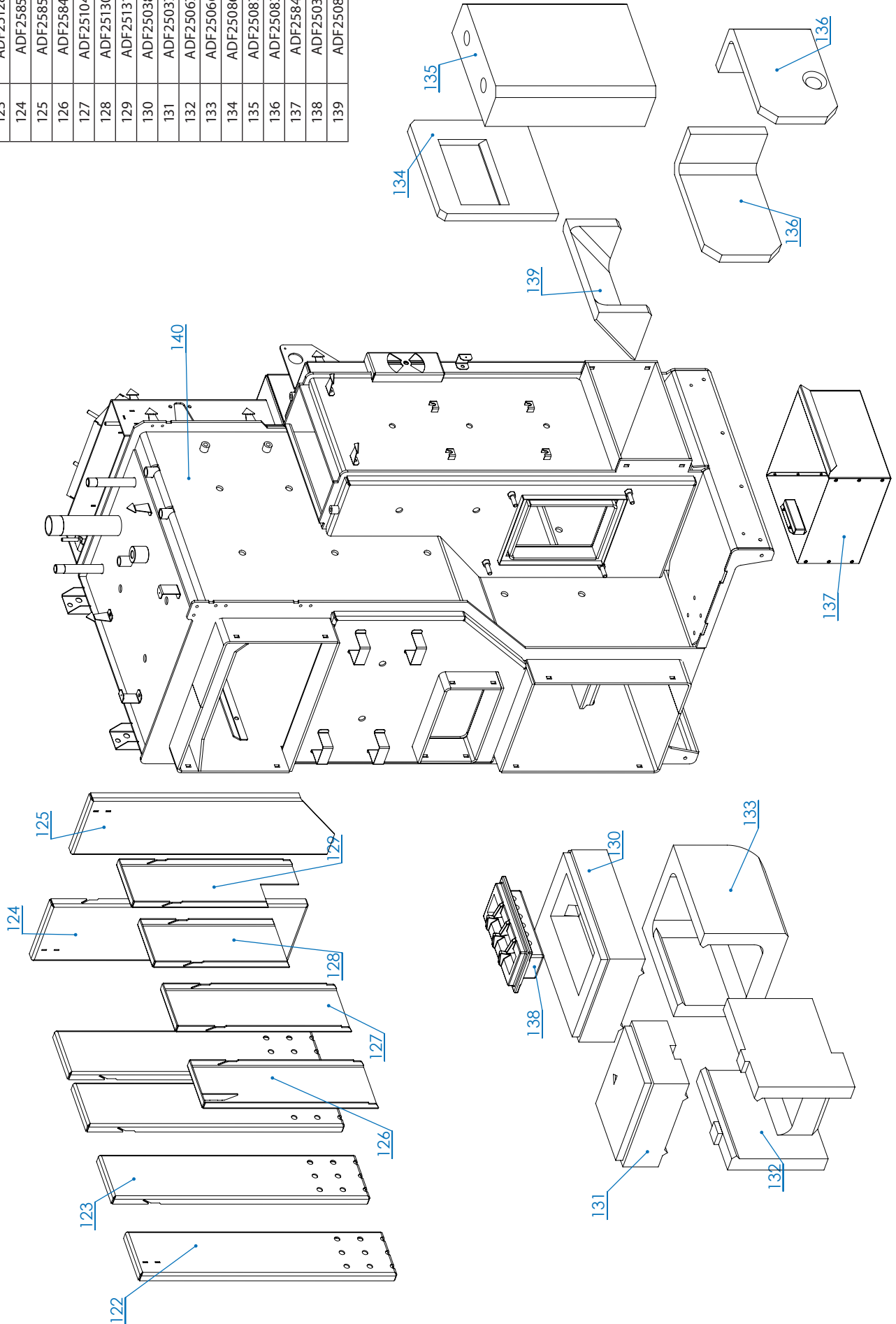

#	CODE
1	ADF25801A
2	ADF25449A
3	ADF25477D
4	ADF25348C
5	ADF25458C
6	ADF25582
7	ADF25579
8	ADF25829

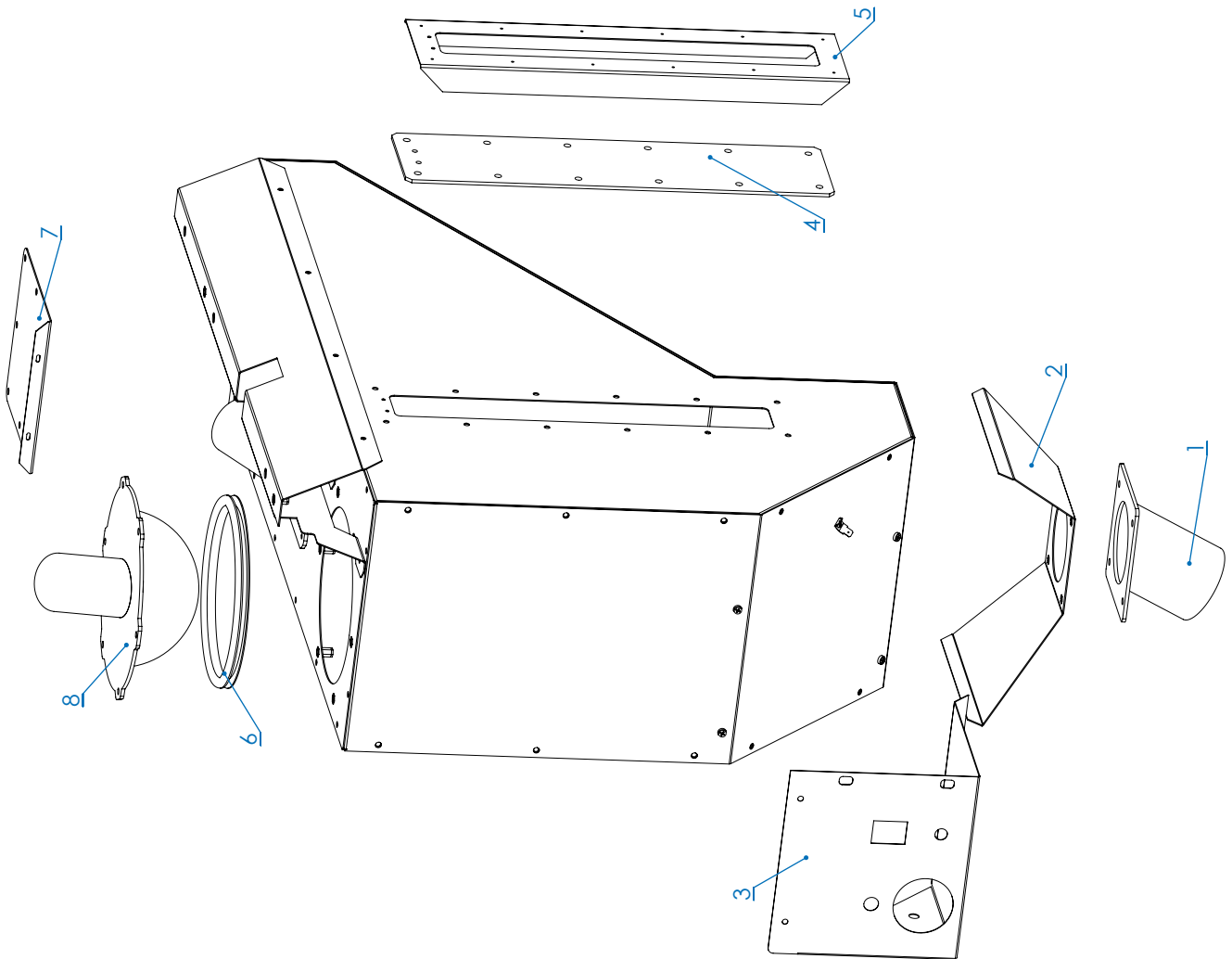

#	CODE
1	PELH30A
2	PELH30996
3	PELH30990
4	PELH30995
5	PELH30998
6	FDA100
7	FDA80
8	SMA017
9	SMA013
10	SM03
11	SMA020
12	SMA016
13	SMA015
14	UK01T
15	UK15
16	DPD25011
17	FDA409
18	FDA933
19	FDA935
20	SMA021
21	SMA019
22	SMA022
23	PEL5000
24	SMA018
25	SMA014
26	FDA422
27	PED150
	PED200
	PED250
28	SM03A7
29	SM15
30	SM16

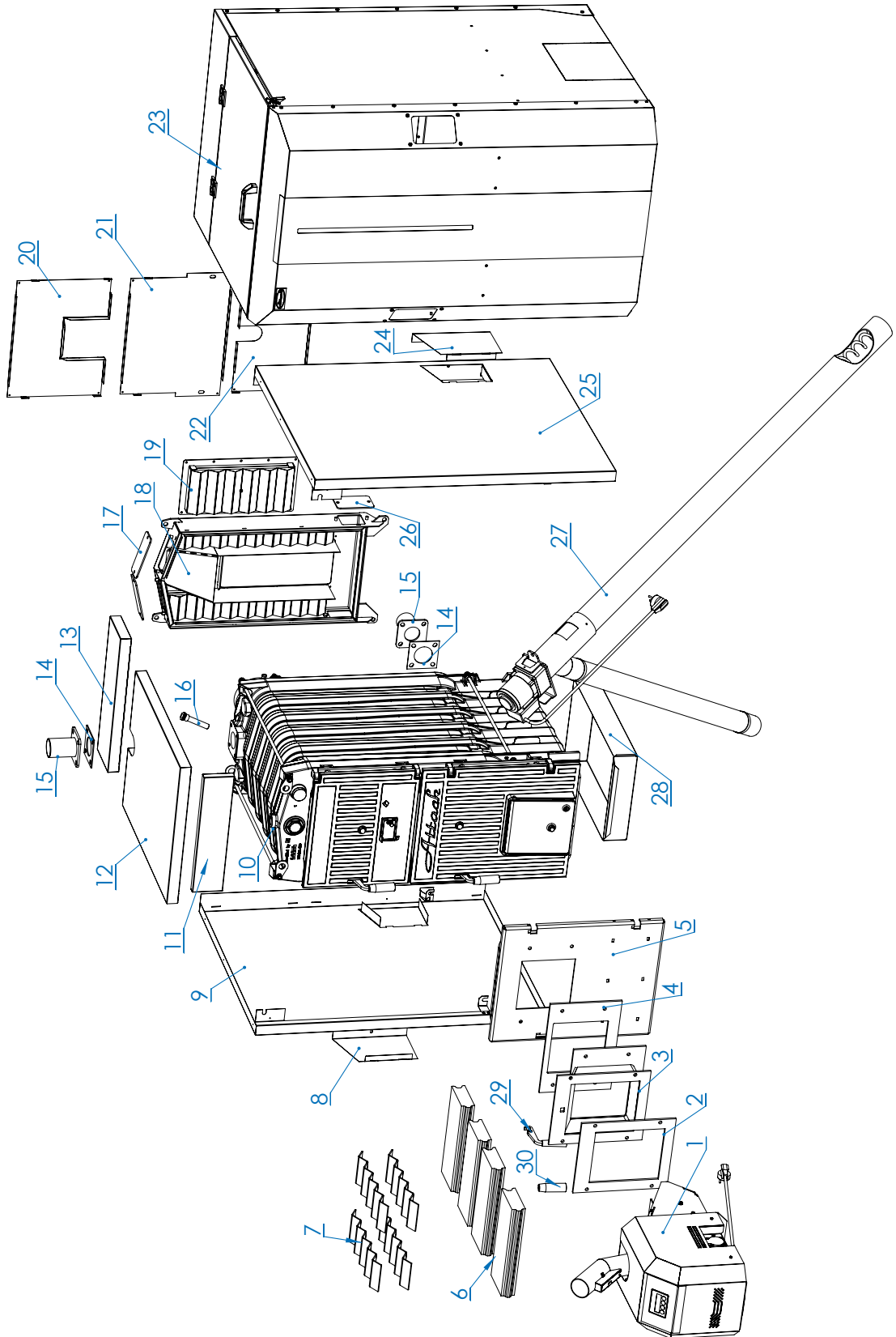

#	CODE	TYPE	#	CODE	TYPE
1	SM08			SM20B	FD32
2	SM08B	FD20-49		SM20C	FD36
3	SM08A			SM20D	FD42
4	SM08C			SM20E	FD49
5	SM09		29	DFD25021	
6	SM26	FD20-49	30	OT11	
7	SM26A	FD20-49	31	SM28	
8	SM26B	FD20-49	32	UK01F	
9	SM17		33	UK01E	
10	SM22		34	SM07A2	FD15
11	SM23			SM01A2	FD20
12	SM12			SM02A2	FD26
13	SM25			SM03A2	FD32
14	SM24			SM04A2	FD36
15	SM14			SM05A2	FD42
16	SM27	FD20-49		SM06A2	FD49
17	SM15		35	SM07A1	FD15
18	SM16			SM01A1	FD20
19	SM01D	FD20		SM02A1	FD26
	SM02D	FD26		SM03A1	FD32
	SM03D	FD32		SM04A1	FD36
	SM04D	FD36		SM05A1	FD42
	SM05D	FD42		SM06A1	FD49
	SM06D	FD49	36	SM07A5	FD15
20	SM07B	FD15		SM01A5	FD20
	SM01B	FD20		SM02A5	FD26
	SM02B	FD26		SM03A5	FD32
	SM03B	FD32		SM04A5	FD36
	SM04B	FD36		SM05A5	FD42
	SM05B	FD42		SM06A5	FD49
	SM06B	FD49	37	SM01A4	
	SM07C	FD15	38	SM01A6	
21	SM01C	FD20	39	SM01A3	
	SM02C	FD26	40	TS099A	
	SM03C	FD32	41	SM07A7	FD15
	SM04C	FD36		SM01A7	FD20
	SM05C	FD42		SM02A7	FD26
	SM06C	FD49		SM03A7	FD32
22	TS103			SM04A7	FD36
23	UK01T			SM05A7	FD42
24	UK15			SM06A7	FD49
25	SM18		42	OT48	
26	SM13		43	SM40	
27	SM19		44	SM41	
28	SM20F	FD15	45	SM42	
	SM20	FD20	46	SM45	
	SM20A	FD26			

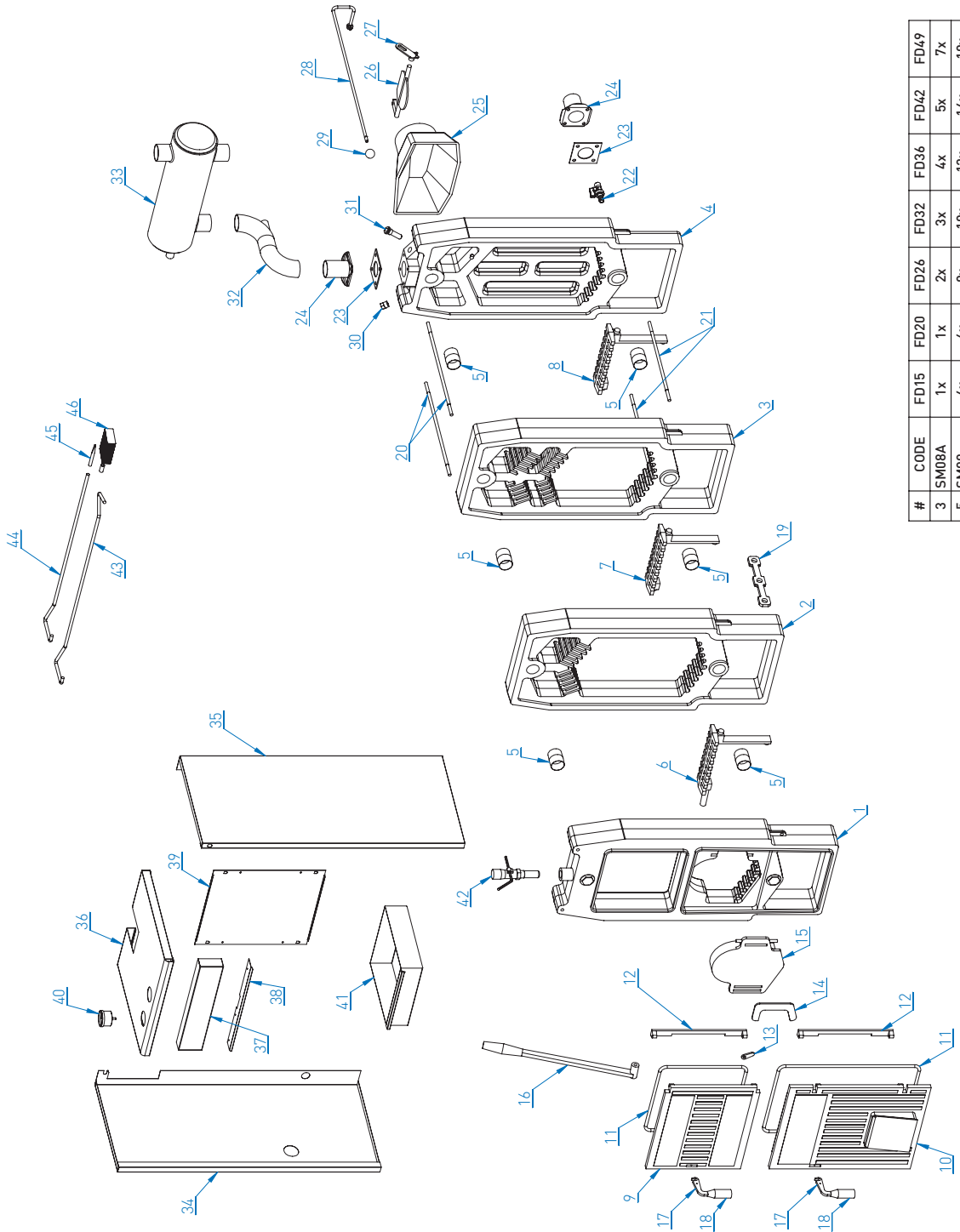

#	CODE	FD15	FD20	FD26	FD32	FD36	FD42	FD49
3	SM08A	1x	1x	2x	3x	4x	5x	7x
5	SM09	4x	6x	8x	10x	12x	14x	18x
7	SM26A	0x	1x	2x	3x	4x	5x	7x

#	CODE
91	FDA920
92	FDA133
93	FDA132
94	FDA922A
95	FDA923
96	FDA156
97	FDA157
98	FDA158
99	FDA310
100	FDA924
101	FDA925
102	FDA161
103	SP221
104	FDA167
105	SP63
106	FDA172

2/2

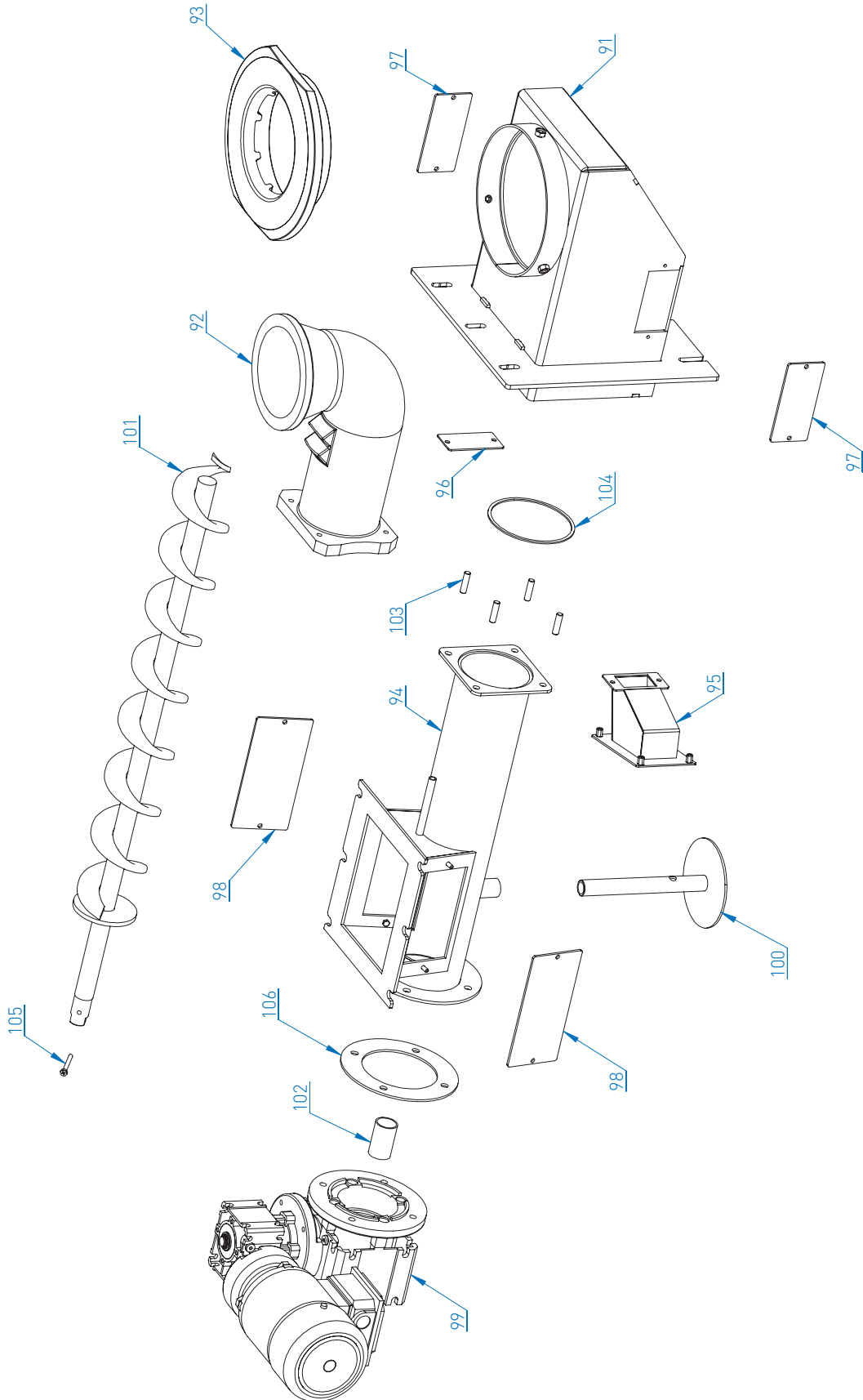

#	CODE	#	CODE
1	FDA900B	41	UK01T
2	FDA032	42	UK15
3	FDA064A	43	TS103
4	FDA110	44	DPD25011
5	FDA111	45	FDA020
6	FDA112	46	FDA019
7	FDA113	47	FDA901
8	FDA114	48	FDA034
9	FDA115	49	FDA031
10	FDA930	50	FDA029
11	FDA067	52	FDA040
12	FDA086	53	FDA025
13	FDA109	54	FDA913
14	FDA101	55	FDA903A
15	SM02A7	56	FDA026
16	FDA911B	59	FDA100
17	FDA950	60	FDA080
18	FDA207	61	FDA131
19	FDA208	62	FDA311
20	FDA209	63	FDA168
21	FDA033A	64	FDA130
22	FDA906	65	PEL0140A
23	FDA018	66	OT11
24	FDA907	67	FDA107
25	RE221	68	TS099A
26	FDA119	69	FDA082A
27	FDA210	70	FDA909
28	FDA915A	71	FDA077
29	FDA300A	72	FDA078
29	FDA300B	73	ADF25807
29	FDA300C	74	ADF25223
29	FDA300D	75	FDA320A
29	FDA300E	76	FDA325
29	FDA300F	77	FDA322
29	FDA300G	78	FDA326
29	FDA300H	79	FDA321
29	FDA300I	80	FDA327
30	FDA301	81	FDA063
31	FDA304	82	FDA328
32	FDA203	83	FDA933
33	ADF25957	84	FDA935
34	FDA125	85	FDA409
35	FDA400	86	FDA422
36	FDA090	87	FDA425
37	SM02X	88	FDA426
38	FDA021	89	FDA427
39	FDA022	90	FDA428
40	FDA200		

1/2

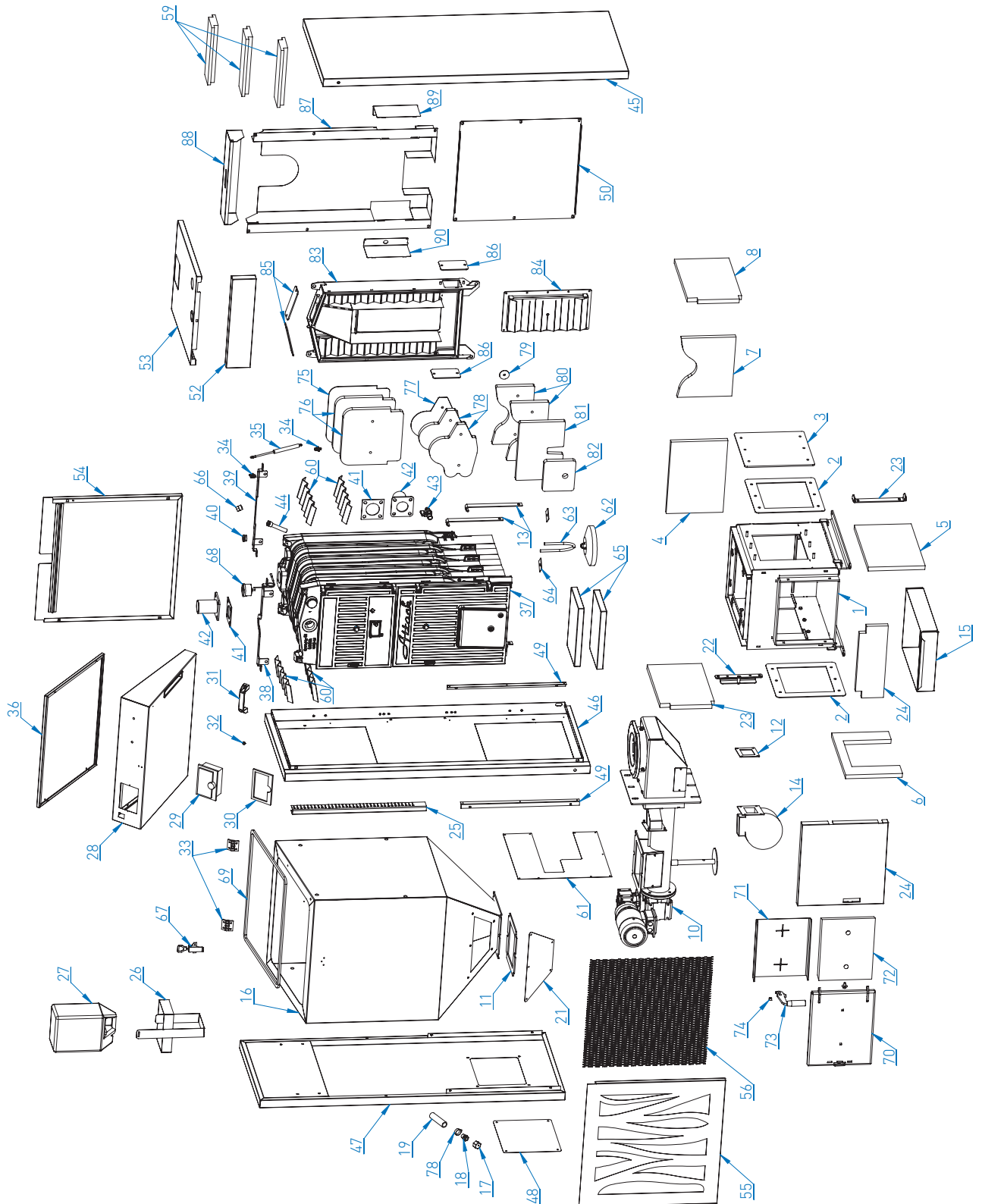

#	CODE
1	PELH30900A
2	H30921C
3	H30930A
4	H30920B
5	H30940A
6	H30001
7	H30009A
8	PR15
9	H30012A
10	H30952
11	H30982
12	H30961B
13	PELH30851
14	PELH30800A
15	TS215
16	PELH30807B
17	H30016E
18	H30809
19	H30820
20	H30970A
21	H30808
22	H30806B
23	H30951B
24	H30807
25	H30118C
26	H30014
27	H30804
28	H30803
29	H30003A
30	H30002
31	TH31
32	PELH30842
33	TH23A
34	OT19C
35	TH05A
36	TH06B
37	H30980
38	ADF25640
39	PELH30830A
40	H30008
41	H30813A
42	H30701C
43	TS094A

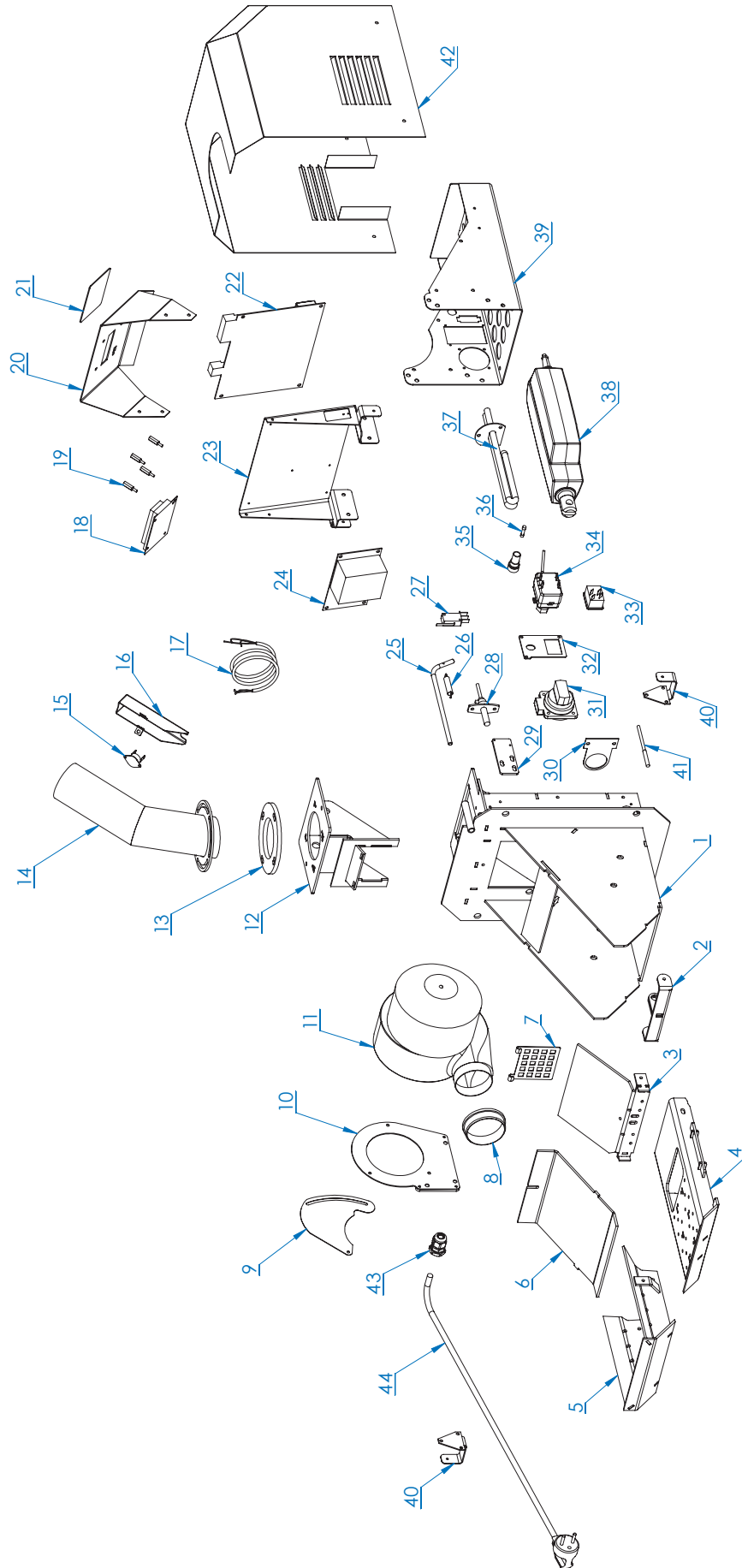

#	CODE
1	PELH30710
2	PELH30711
3	PELH30620
4	PEL30680
5	PELH30903A
6	PELH30610A
7	PELH30851
8	PELH30800A
9	TS215
10	PELH30807B
11	H30016D
12	H30809
13	H30820
14	H30970A
15	H30808
16	H30806B
17	H30951B
18	H30701C
19	PELH30830A
20	PELH30630
21	H30984
22	PELH30664
23	H30980A
24	H30803
25	H30014
26	PELH30678
27	H30804
28	TH31
29	PELH30842
30	TH23A
31	OT19C
32	TH05A
33	TH06B
34	TS094A
35	TS091
36	PEL30615
37	H30813A

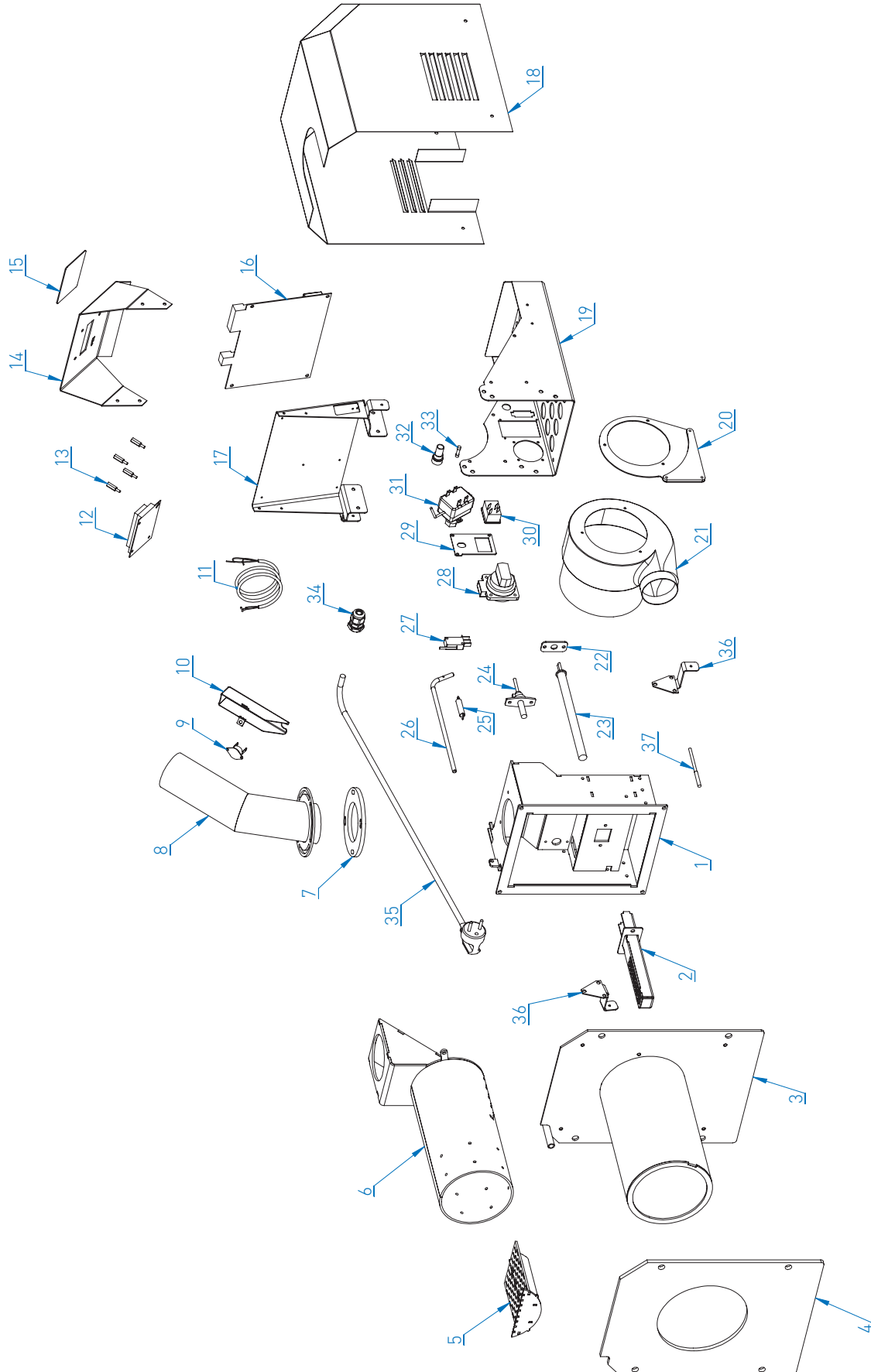

#	CODE
1	PELH30997
2	PELH30970
3	SP176
4	SM15

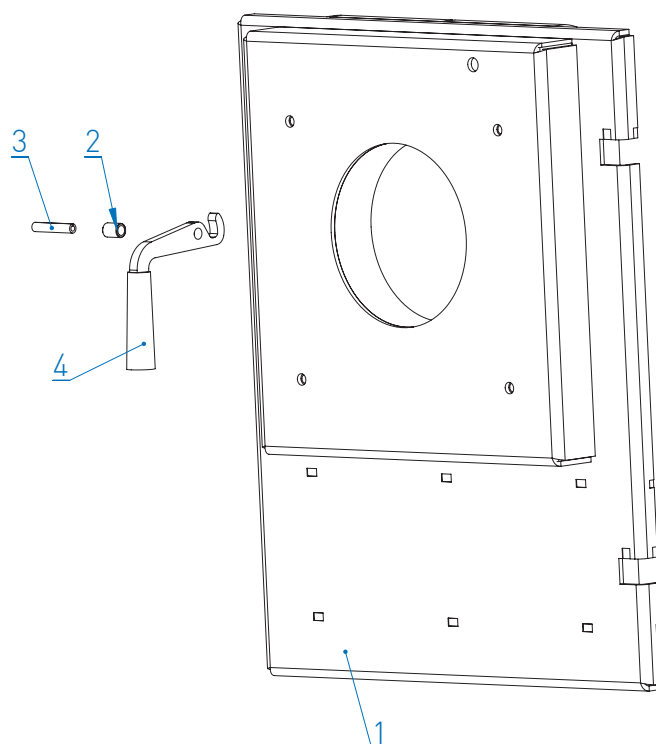

# ATTACK PELH30980

4/2013 -

#	CODE
1	PELH30980
2	PELH30990
3	PELH30995
4	PELH30996
5	SM15
6	SP176
7	PELH30970

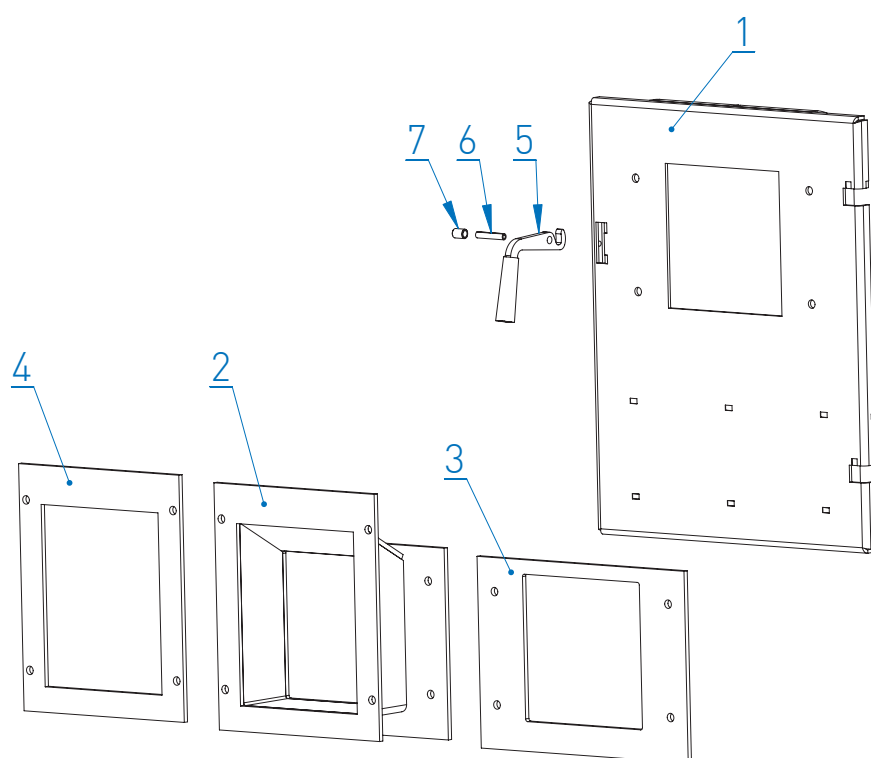

#	CODE
1	PEL5914A
2	PEL5901B
3	PEL5032
4	PEL5014
5	PEL5902A
6	PEL5907
7	PEL5909
8	PEL5906
9	PEL5903A
10	PEL5913A
11	PEL801
12	PEL5915A
13	PEL5908A
14	PEL5905A
15	PEL9717
16	PEL5916
17	ADF25618
18	PEL5911
19	PEL5028
20	PEL5919
21	PEL802
22	SS01

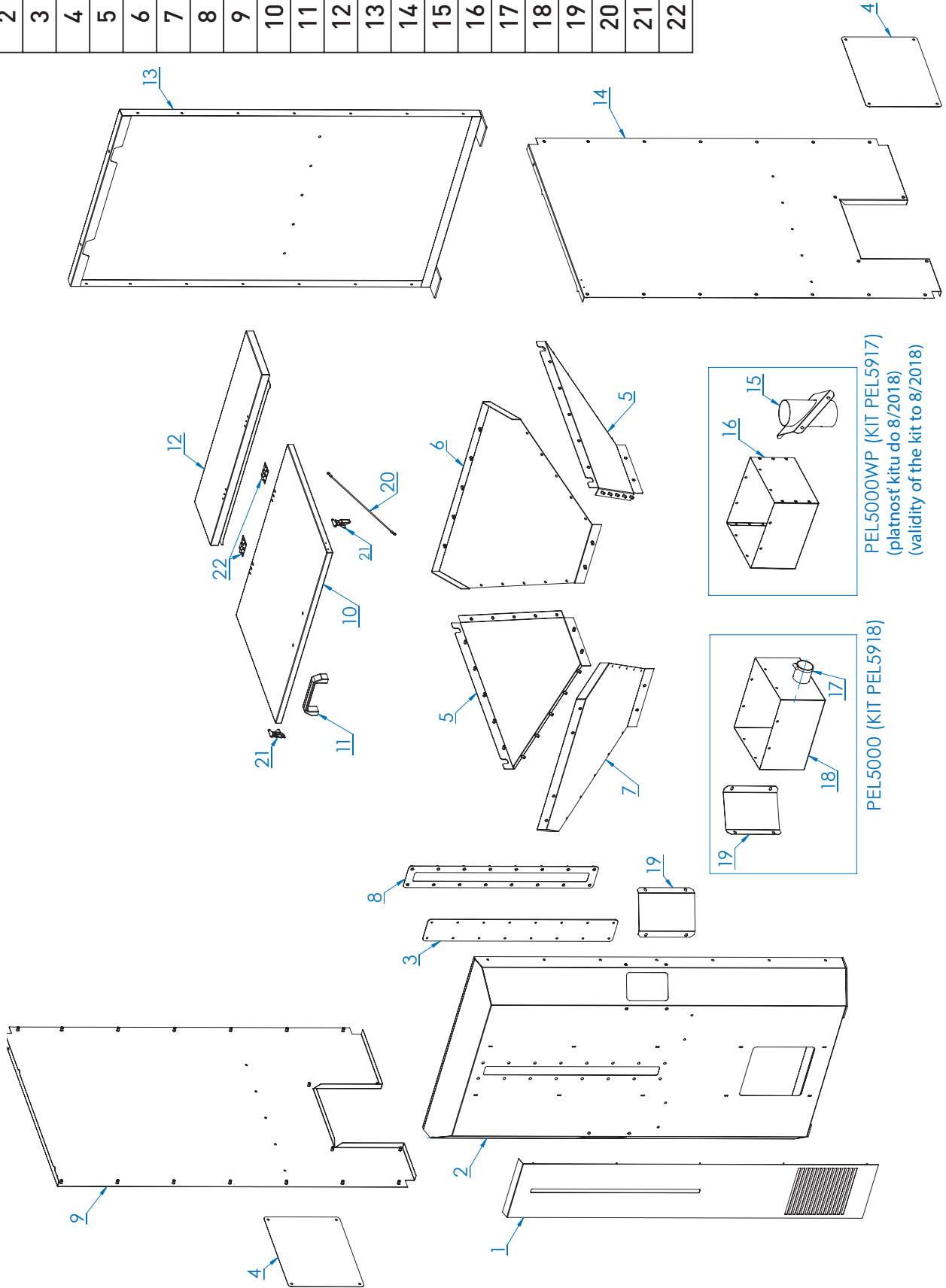

#	CODE
1	PEL5914B
2	PEL5901B
3	PEL5028
4	PEL5921
5	PEL5905C
6	PEL5908C
7	PEL5920
8	ADF25618
9	PEL5032A
10	PEL5010A
11	PEL5044A
12	PEL5046A
13	PEL5045A
14	PEL5005B
15	ADF25957
16	PEL5913C
17	PEL802
18	FDA304
19	PEL5012C

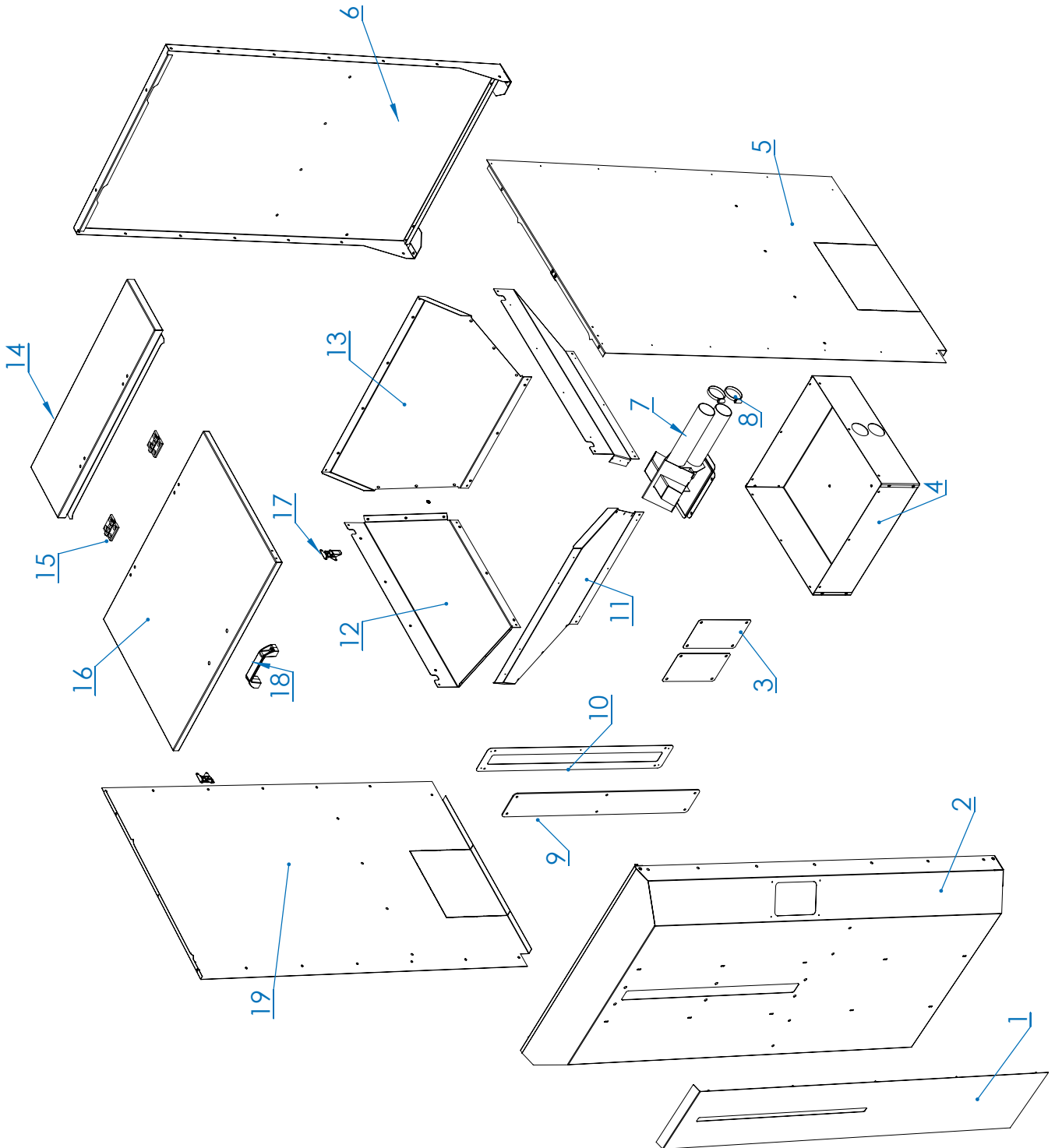

#	CODE	TYPE
1	PED15905	
2	PEL937	
3	PED15902B	PED150
	PED20001	PED200
	PED20902A	PED210
	PED25901	PED250
4	PED15001B	PED150
	PED20003B	PED200
	PED20003B	PED210
	PED25010	PED250
5	PED15008	
6	PED15009	
7	TS091B	

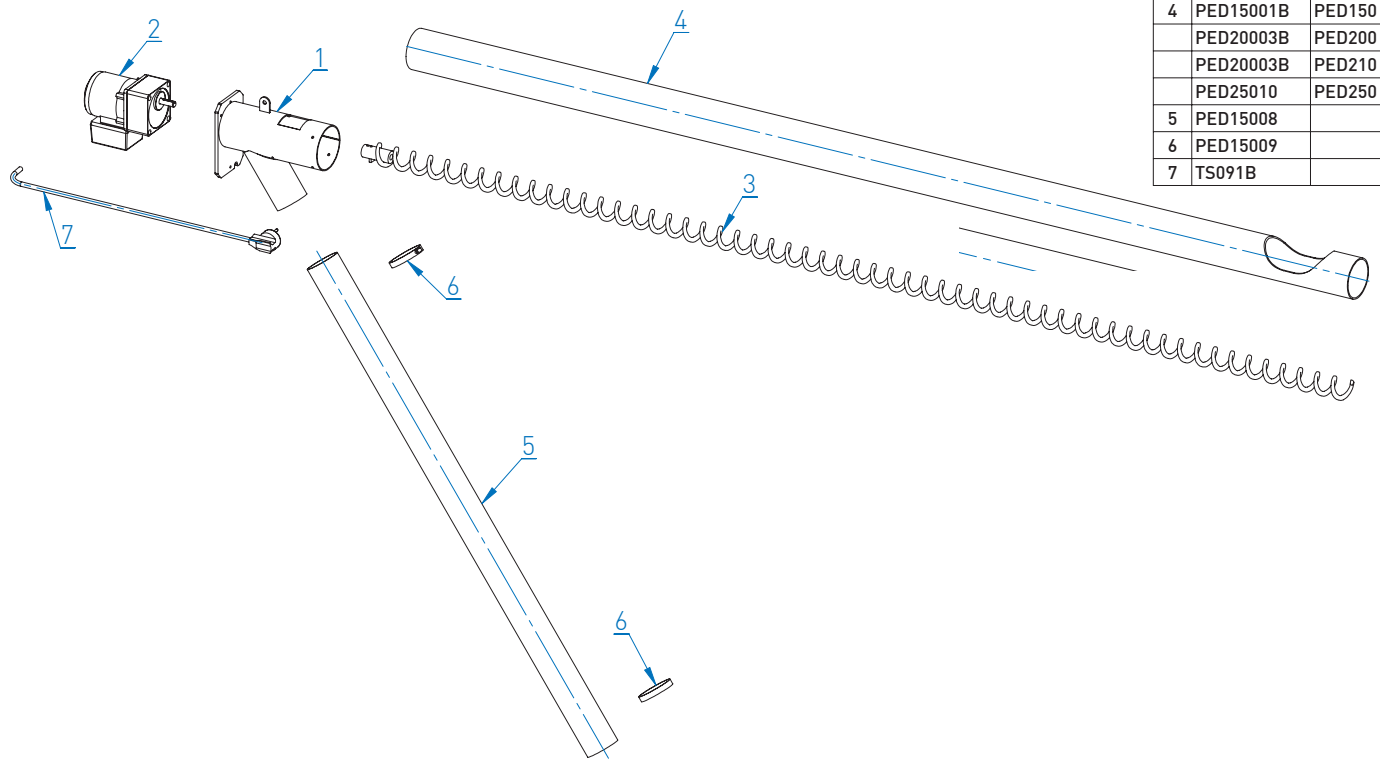

# ATTACK PED150A

#	CODE
1	PED15905
2	PED15102A
3	PEL937
4	PEL9733
5	PEL9739
6	PED15008
7	PED15009
8	PED15106
9	PED15105C
10	PEL9736A
11	TS091B

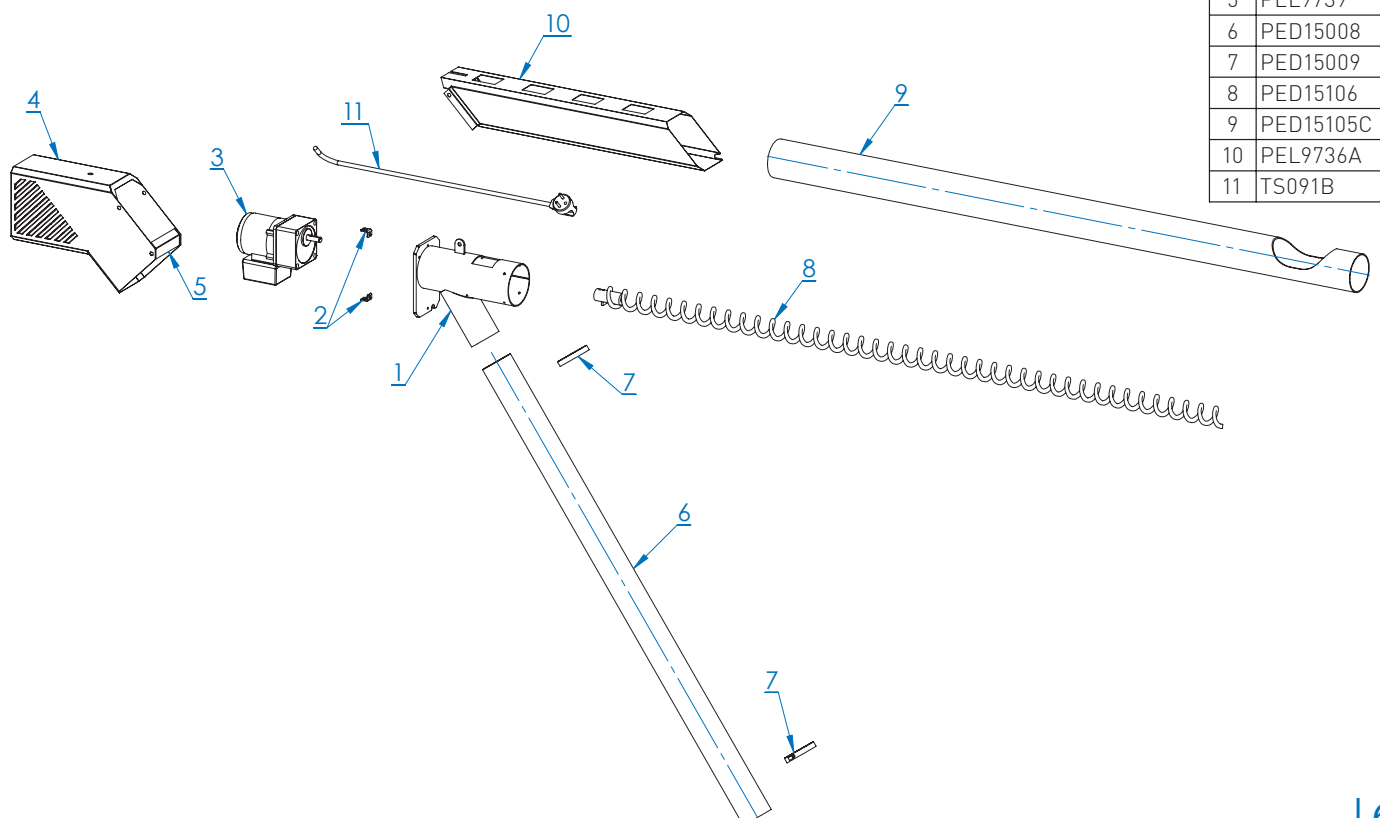

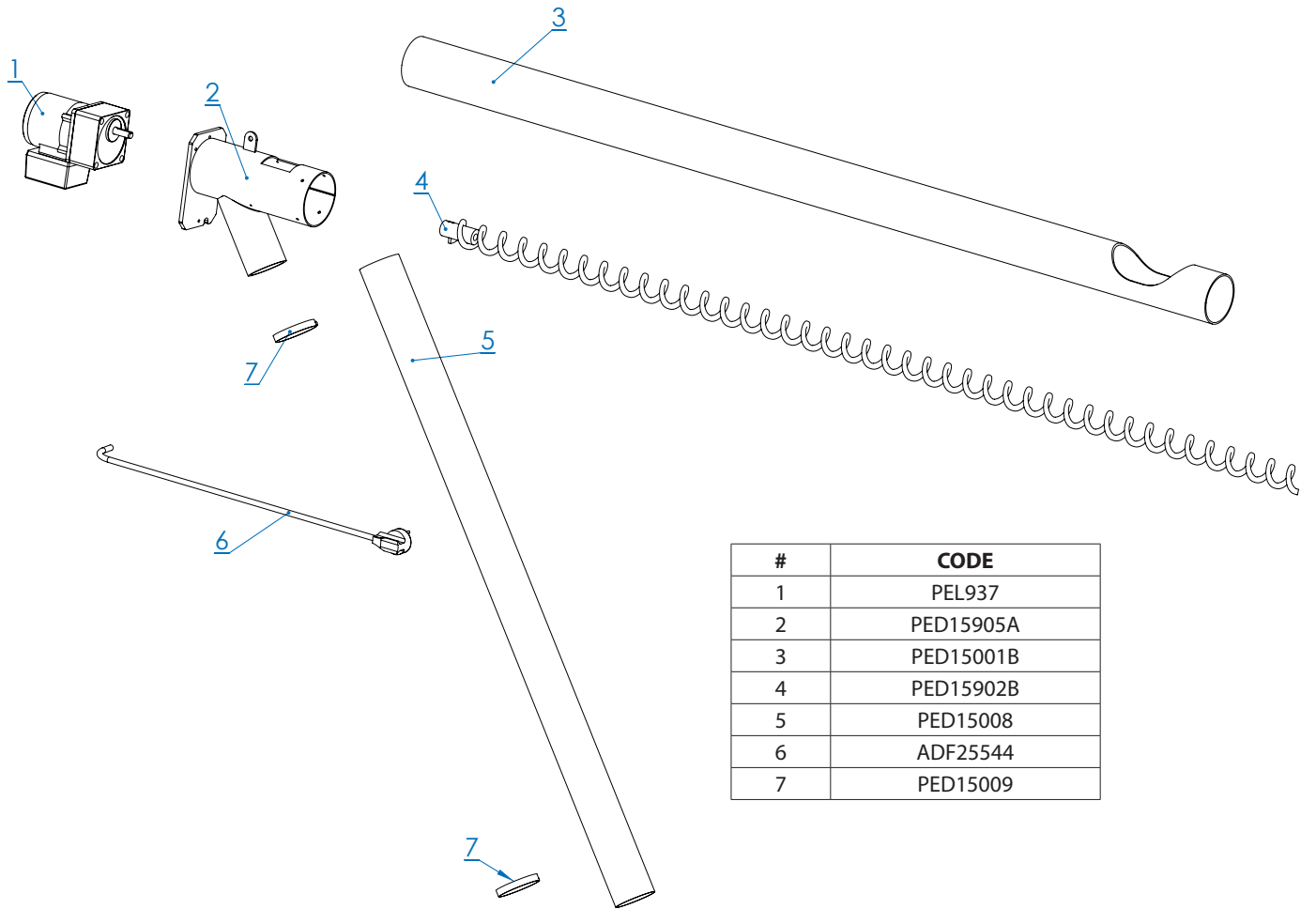

#	CODE
1	PEL937
2	PED15905A
3	PED15001B
4	PED15902B
5	PED15008
6	ADF25544
7	PED15009

# ATTACK PED150A

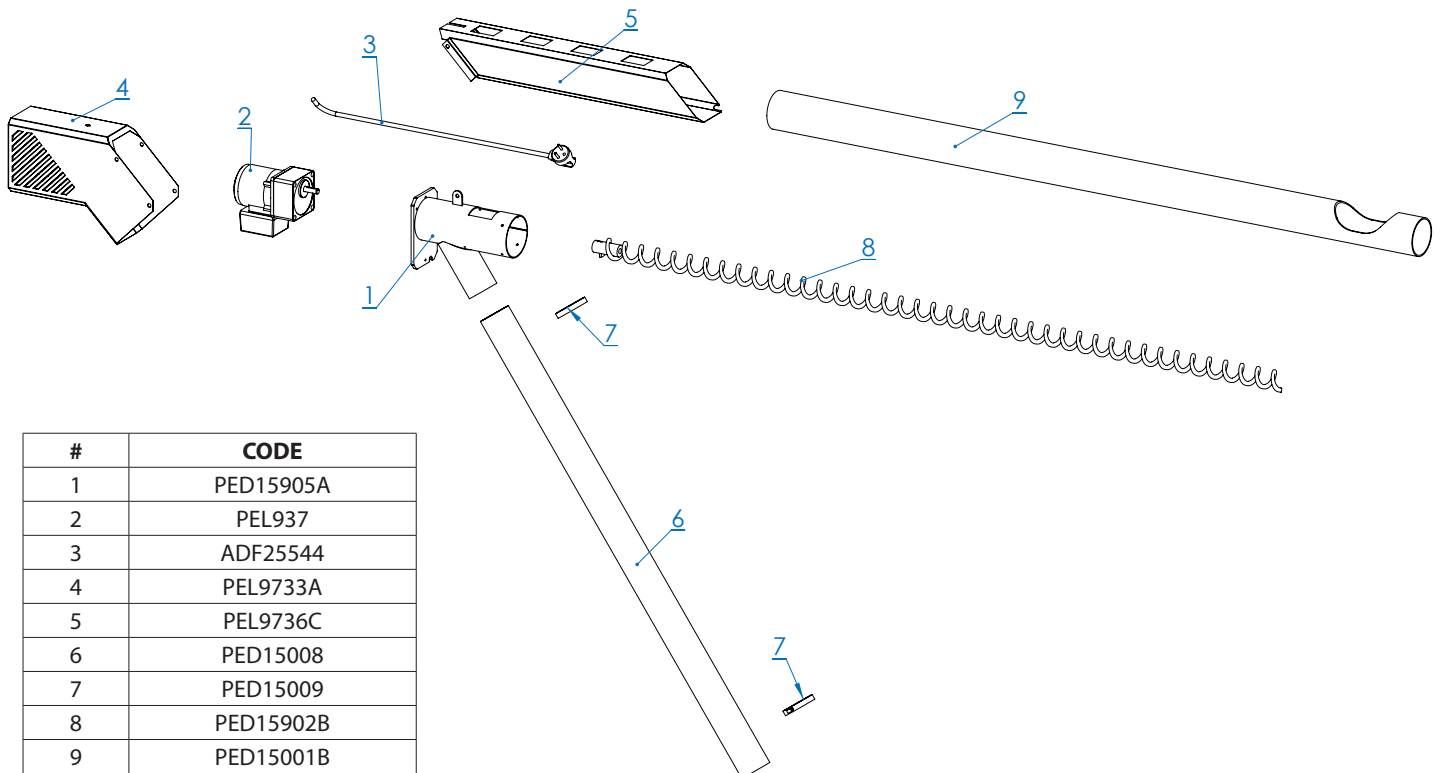

#	CODE
1	PED15905A
2	PEL937
3	ADF25544
4	PEL9733A
5	PEL9736C
6	PED15008
7	PED15009
8	PED15902B
9	PED15001B

#	CODE
1	PED20004
2	PED20003B
3	PED15905A
4	PED15013
5	PED15015
6	PEL938
7	PED15008
8	ADF25544
9	PED15009

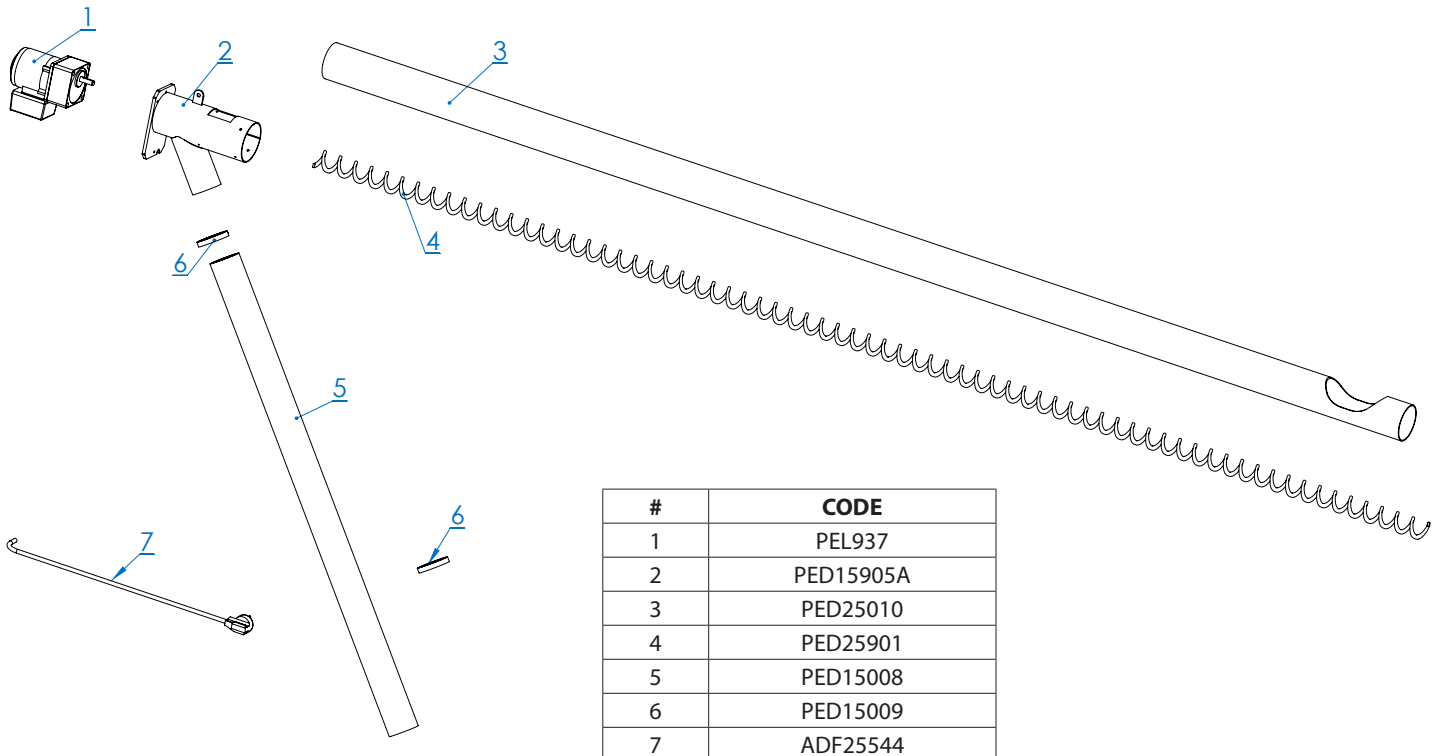
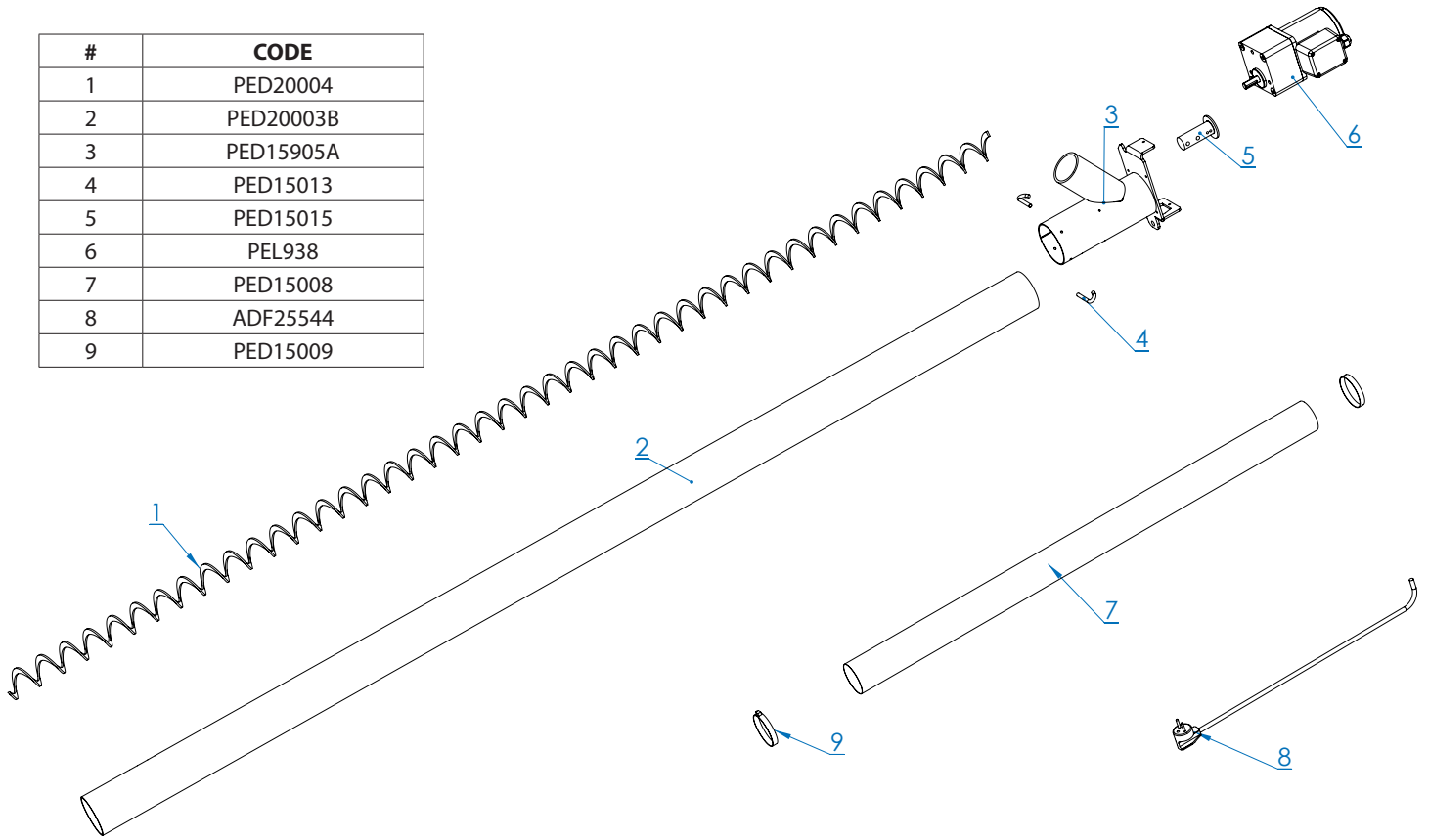

#	CODE
1	PEL937
2	PED15905A
3	PED25010
4	PED25901
5	PED15008
6	PED15009
7	ADF25544

#	CODE
1	DPD25903A
2	DPD25016D
3	DPV25081
4	DPD25001B
5	DPD25080
6	DPD25090
7	DPD25016A

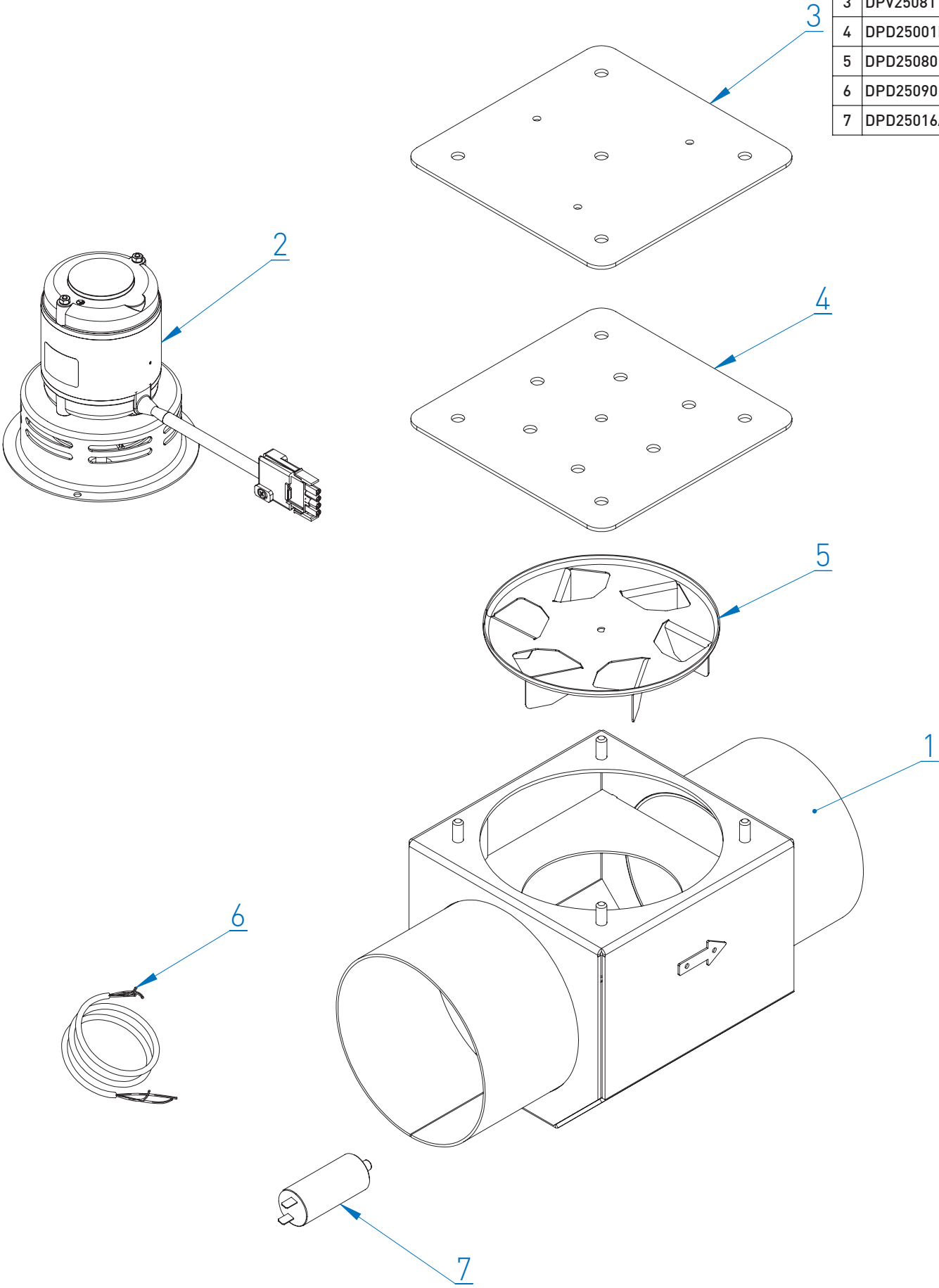

#	CODE	TYPE
24	SFO921	FD20
	SFO904	FD26
	SFO909	FD32
	SFO913	FD36
	SFO918	FD42
25	DPD25021	
26	SFO041	
27	SFD014	
28	SFD015	
29	SM28	
30	SFD003	
31	SFD002	
32	SFD001	
33	SM09	
34	SM19	
35	SFD004	FD20
	SFD005	FD26
	SFD006	FD32
	SFD007	FD36
	SFD008	FD42
36	SFD016	
37	SFD017	
38	SFD018	
39	SFD009	
40	SFD010	
41	SFD012	
42	SFD013	
43	SFD027	
44	SFD026	
45	SFD025	
46	SFD019	
47	SFD020	
48	SFD021	
49	SFD022	
50	SFD023	
51	SFD024	

#	CODE	TYPE
1	SMA40	
2	SMA41	
3	SMA45	
5	SMA42	
6	SFO934	FD20
	SFO935	FD26
	SFO936	FD32
	SFO937	FD36
	SFO933	FD42
7	SMA004	
8	SMA002	FD26,FD32,FD36,FD42
9	SFO920	FD20
	SFO903	FD26
	SFO908	FD32
	SFO912	FD36
	SFO917	FD42
10	SMA008	FD32,FD36,FD42
11	SMA001	
12	SMA003	FD26,FD32,FD36,FD42
13	TS103	
14	SMA007	
15	SMA006	FD20
	SMA009	FD26
	SMA005	FD32
	SMA011	FD36
	SMA012	FD42
16	SMA005	
18	SFO923	FD20
	SFO924	FD26
	SFO925	FD32
	SFO926	FD36
	SFO927	FD42
19	OT48	
20	DPD25018A	
21	UK15	
22	UK01T	
23	SFO036	FD20
	SFO012	FD26
	SFO024	FD32
	SFO030	FD36
	SFO031	FD42

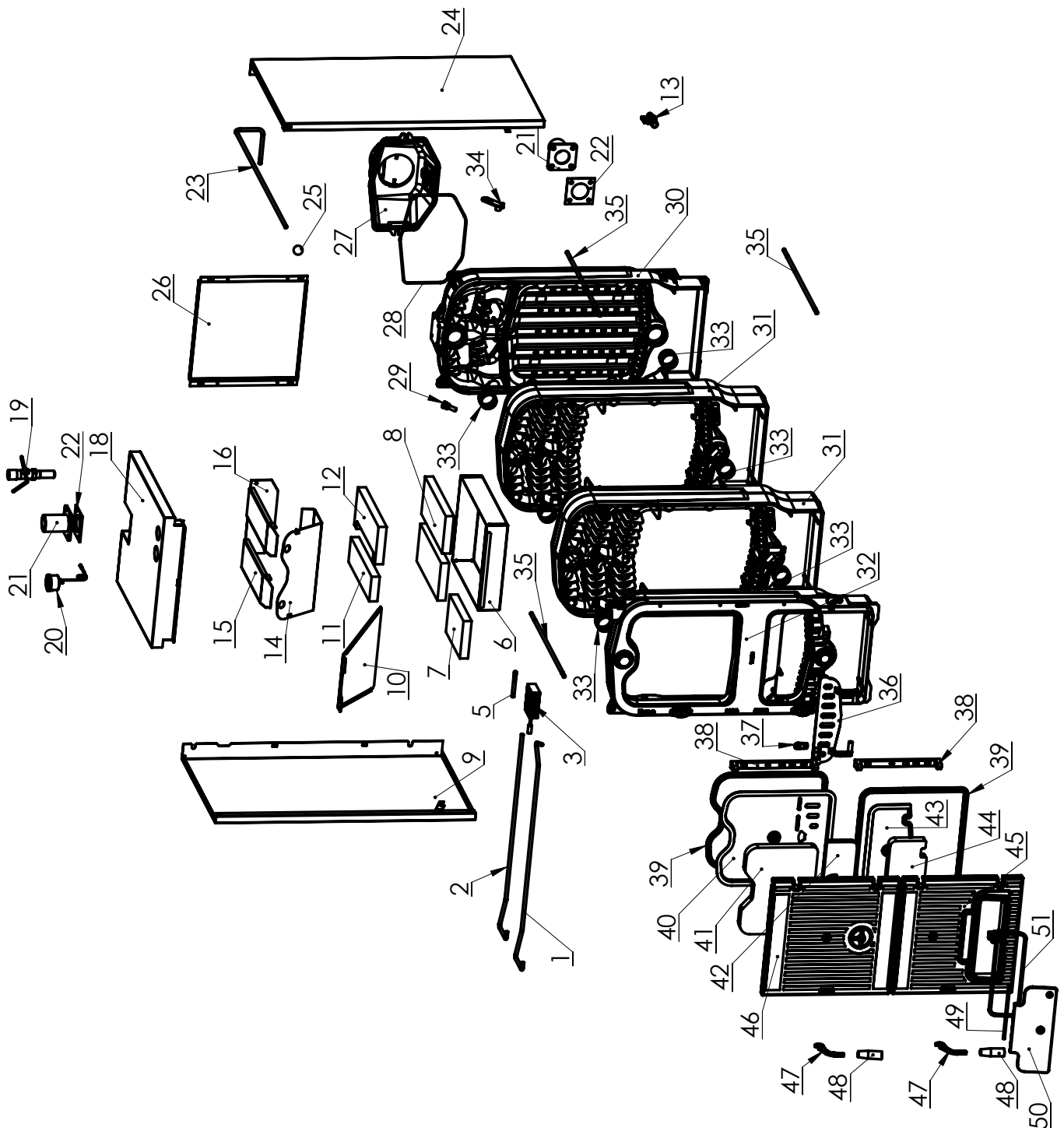

#	CODE	#	CODE
1	DP25400	30	DPD25011
	DP35400	31	TS106
	DP45400	32	DPD25110
	DP25500	33	DPD45110
	DP35500	34	DPV25089B
	DP45500	35	DPV25074D
	DPV25382D	36	DPV25530
	DPV35382D	37	DPV25041
	DPV45382D	38	DPA25900
	DP25002	39	DPV25102A
	DP25010	40	TS103
	DP25011	41	DPD25020
	DP35011	42	DPD2501B
	DP45011	43	DPV25081
	DP25104	44	DPD25016D
	DP35104	45	DPD45001D
	DP45104	46	DPD25420B
	DPV25104	47	DPA25909
	DP35103	48	DPA25912
	DP45103	49	DPA25901
	DPA15901	50	DPA25902
	DPA25007	51	DPA25044
	DPA35007	52	DPV25095A
	DPA45007	53	DPD25030
	DPV25080	54	DPV25108
	DPA15902	55	DPV95086
	DPA25006	56	DPD25521A
	DPA35006	57	PEL0490
	DPA45006	58	DPC25005A
	DPA25009	59	DPC25009
	DPA35009	60	SM45
	DPA45009	61	STANDARD
	DP25011	62	TH05A
	DP35011	63	TH06
	DP45011	64	DPD25009A
	DPD25016A	65	DPD25010
	DPD45001A	66	DPV25099A
	TS094A	67	DPA15013
	TS091	68	DPD15020
	DPD25069	69	OT19C
	DPV25620	70	DPD25008A
	DPV35620	71	DPD25007B
	DPV45620	72	DPD25073
	DPD25059	73	DPD25034
	DPD25061	74	AT46C
	OT11	75	DPA15015
	DPD25029	76	DPD15030
	DPV25102B		

PROFI

STANDARD

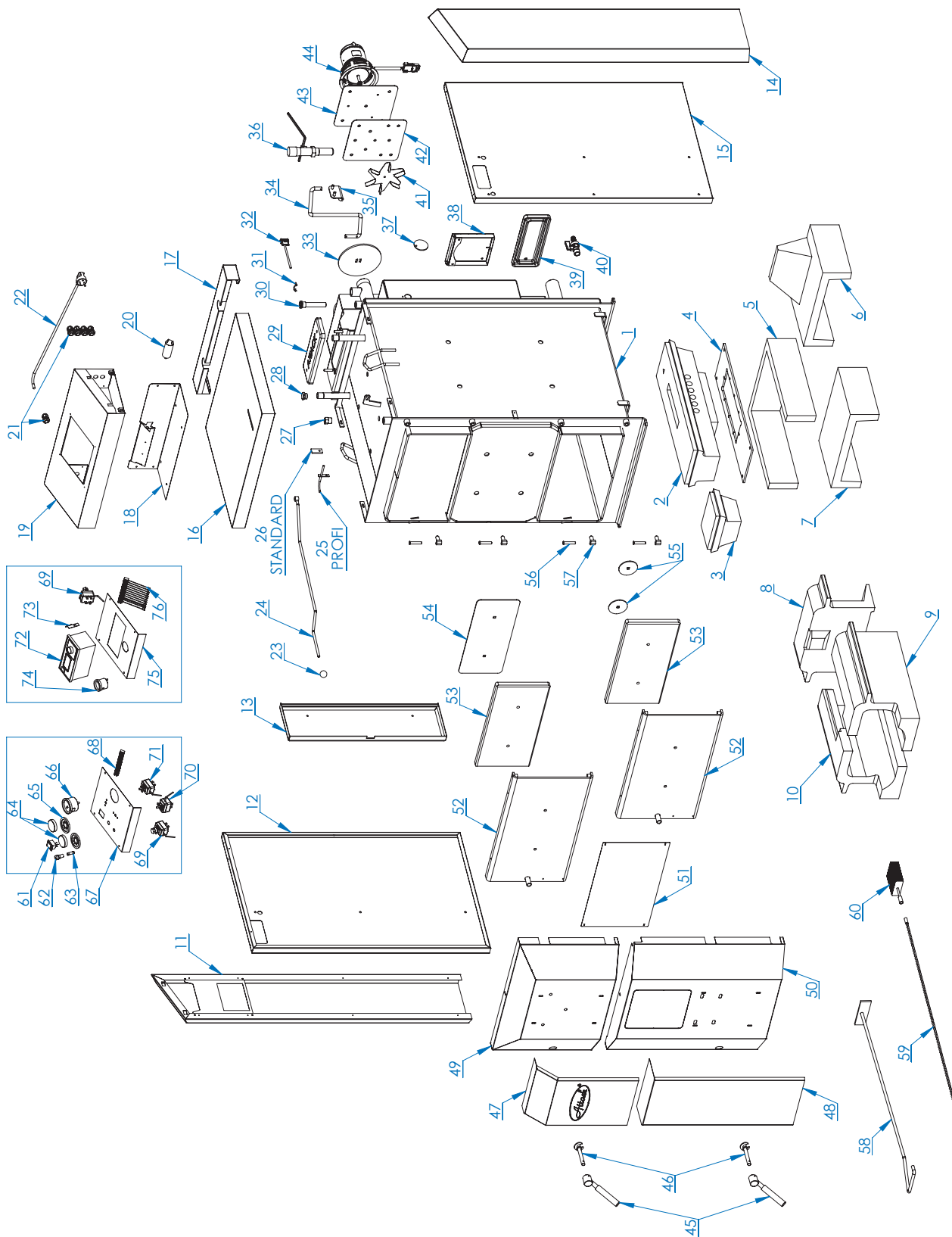

#	CODE	
32	DPV45620	45
33	DPD25069	
34	OT11	
35	DPA15025	
36	DPA15904	
37	DPA25007	25
	DPA35007	35
	DPA45007	45
38	DPA15901	
39	DPC25005A	
40	PEL0490	
41	DPO25521A	
42	DPV25095A	
43	DPA25901	
44	DPA25907	
45	DPD25030A	
46	DPV25108	
47	DPD25430	
48	DPD25420B	
49	DPV15087	
50	DPV25095A	
51	DPD25030A	
52	DPA25902	
53	DPA25912	
54	DPA25044	
55	DPD25008A	
56	DPD25009	
57	OT19C	
58	TH05A	
59	TS095A	
60	TH06	
61	DPD15020	
62	DPD25007	
63	DPD25016A	
64	TS099A	
65	DPD25010	
66	DPA15013	
67	DPA15015	
68	OT19C	
69	AT46C	
70	TS094A	
71	DPD15030	
72	DPD25073	
73	DPD25059	
74	DPD25016A	
75	DPD25034	

#	CODE	
1	DP25400	25
	DP35400	35
	DP45400	45
2	DPP25105	25
	DPP35103	35
	DPP45103	45
3	DPP25104	
	DPT25004	25
4	DPT35005	35
	DPT45004	45
5	DPP25106	25
	DPP35104	35
	DPP45104	45
6	DPT35004	35,45
	DPA25006	25
	DPA35006	35
	DPA45006	45
8	DPA15907	
9	DPC25009	
10	SM45	
11	TS103	
12	DPV25102A	
13	DPA25900	
14	DPD25016D	25,35
	DPD45001D	45
15	DPV25081	
16	DPD25001B	
17	DPD25020	
18	DPV25530	
19	DPV25089B	
20	DPV25041	
21	DPV25074D	
22	DPD25110	25,35
	DPD45110	45
23	DPV25102B	
24	DPA25009	25
	DPA35009	35
	DPA45009	45
25	DPA25011	
26	TS106	
27	DPP25005	
28	DPD25011	
29	OT39C	
30	TS091	
31	DPD25029	
	DPV25620	25
32	DPV35620	35

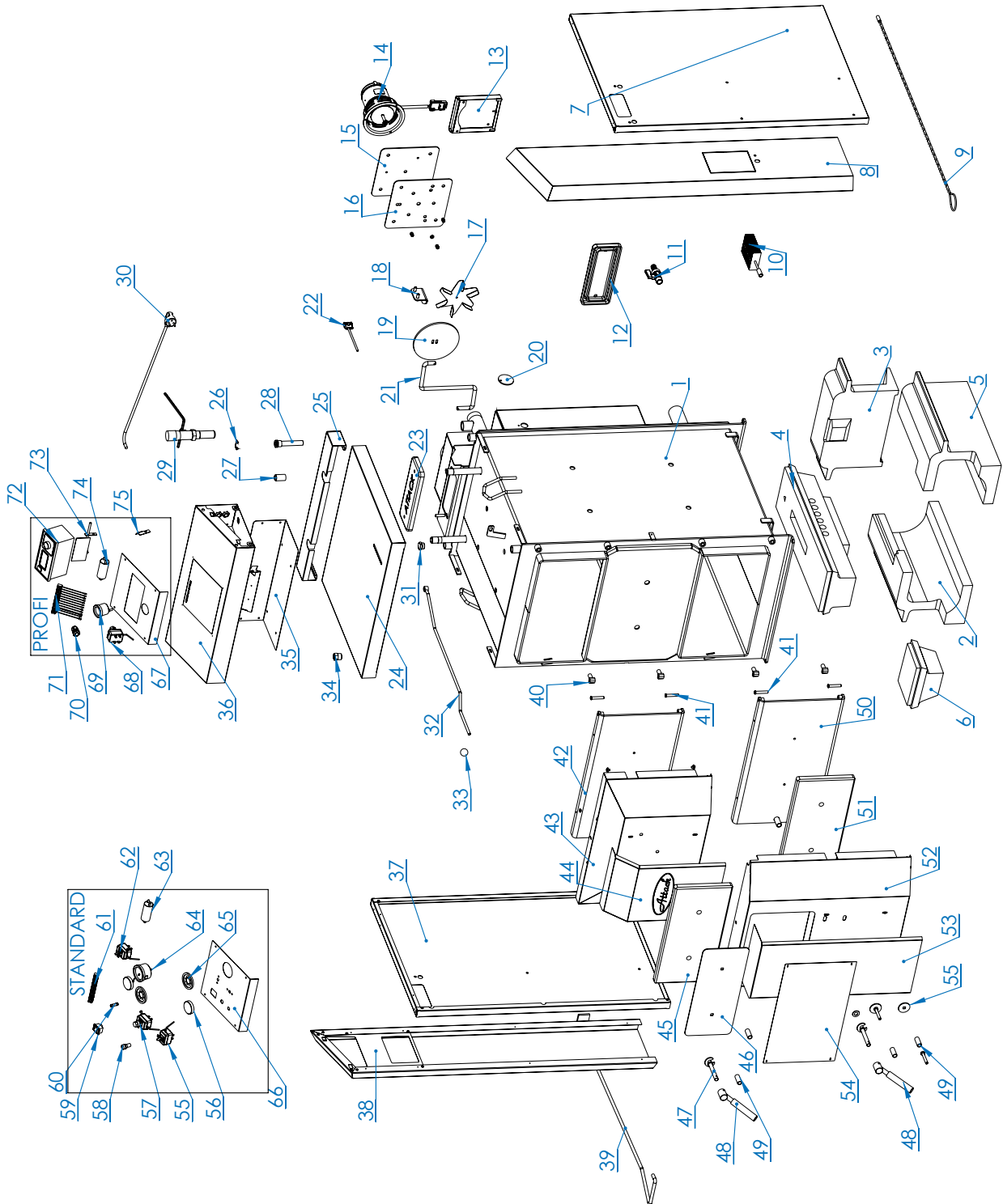

#	CODE	#	CODE
1	DP75003	31	DPV25089B
2	DPT95002A	32	DPV25102B
3	DPT95003	33	DPV95100
4	DPP95108B	34	DPD25069
5	DPP95107B	35	DPD75002B
6	DPP95105B	36	DPD25027
7	DPP95106B	37	OT19C
8	DPD25420B	38	TH05A
9	DPD25430	39	TH06
10	DP075011	40	TS095A
11	DP075001	41	DPD25007B
12	DPV75027	42	DPD25008A
13	DPD95002	43	DPD25010
14	DPV75047	44	DPD25009A
15	DPV95086	45	TS099A
16	DPV75031	46	DPD45120
17	DPV75046	47	DPD25061
18	DP075005A	48	DPD25029
19	DPV75030	49	OT11
20	DP075010	50	DPD25011
21	DP075009	51	TS106
22	DPV25101A	52	OT39C
23	DP075006	53	TS094A
24	DPV25102A	54	TS091E
25	DPD75003	55	DPV25041
26	DPD75001A	56	TS103
27	DPV75015	57	SM45
28	DPD75002E	58	DPC25009
29	DPV25530	59	DPC75001
30	DPV25074D		

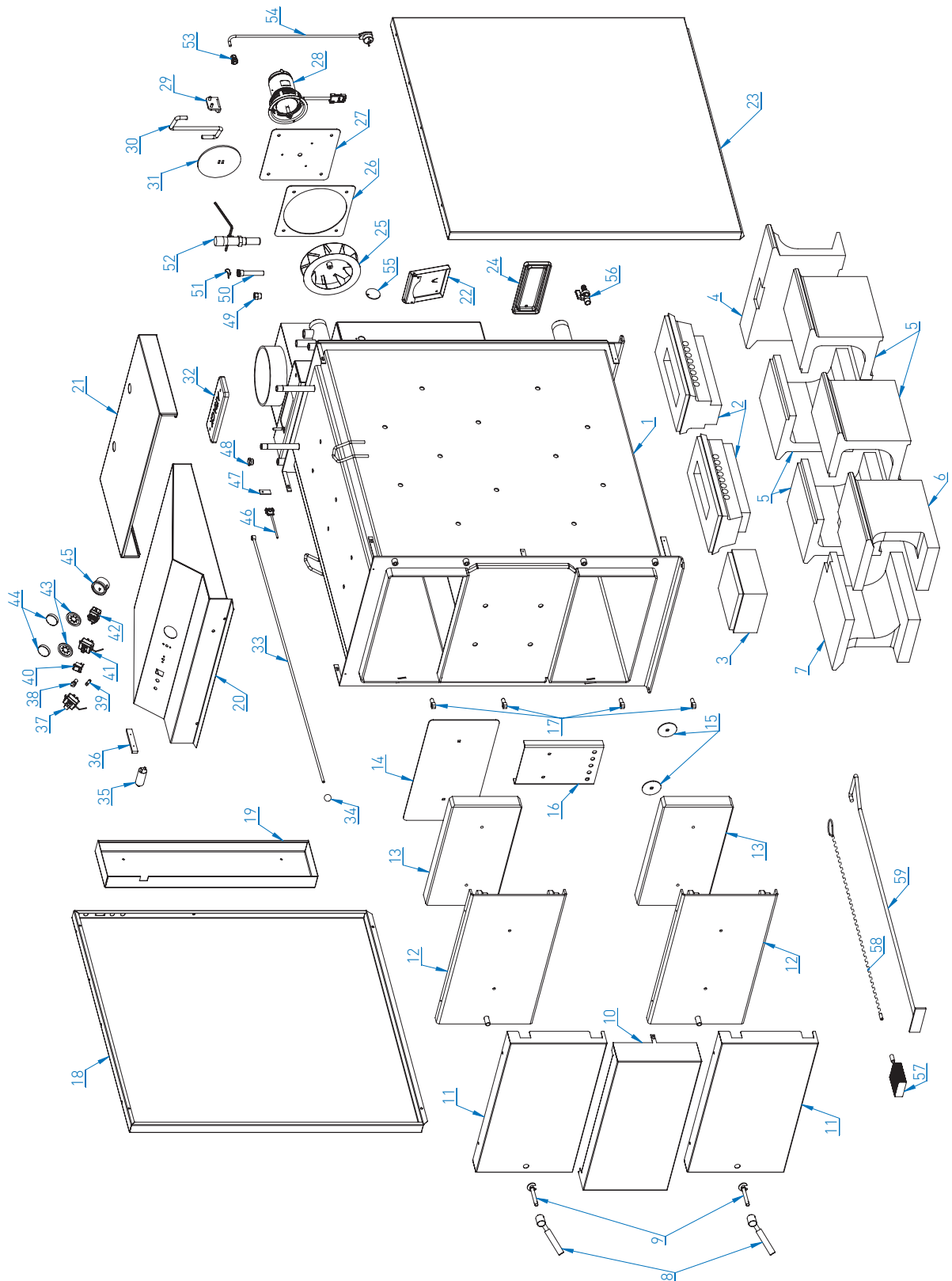

#	CODE	#	CODE
1	DPV5003	29	DPV25530
2	DPT95002A	30	DPV25074D
3	DPT95003	31	DPV25089B
4	DPP95108B	32	DPV25102B
5	DPP95107B	33	DPV95100
6	DPP95105B	34	DPD25069
7	DPP95106B	35	DPD75002B
8	DPD25420B	36	DPD15030
9	DPD25430	8/2015 -	
10	DP075011	37	OT19C
11	DP075001	38	DPD25073
12	DPV75027	6/2014 -	
13	DPD95002	39	DPD25034
14	DPV75047	40	DPD45120
15	DPV95086	41	DPD25059
16	DPV75031	42	DPD25029
17	DPV75046	43	OT11
18	DP075005A	44	DPD25011
19	DPV75030	45	TS106
20	DP075008	46	OT39C
21	DP075009	47	TS094A
22	DPV25101A	48	TS091E
23	DP075006	49	DPV25041
24	DPV25102A	50	TS103
25	DPD75003	51	SM45
26	DPD75001A	52	DPC25009
27	DPV75015	53	DPC75001
28	DPD75002E		

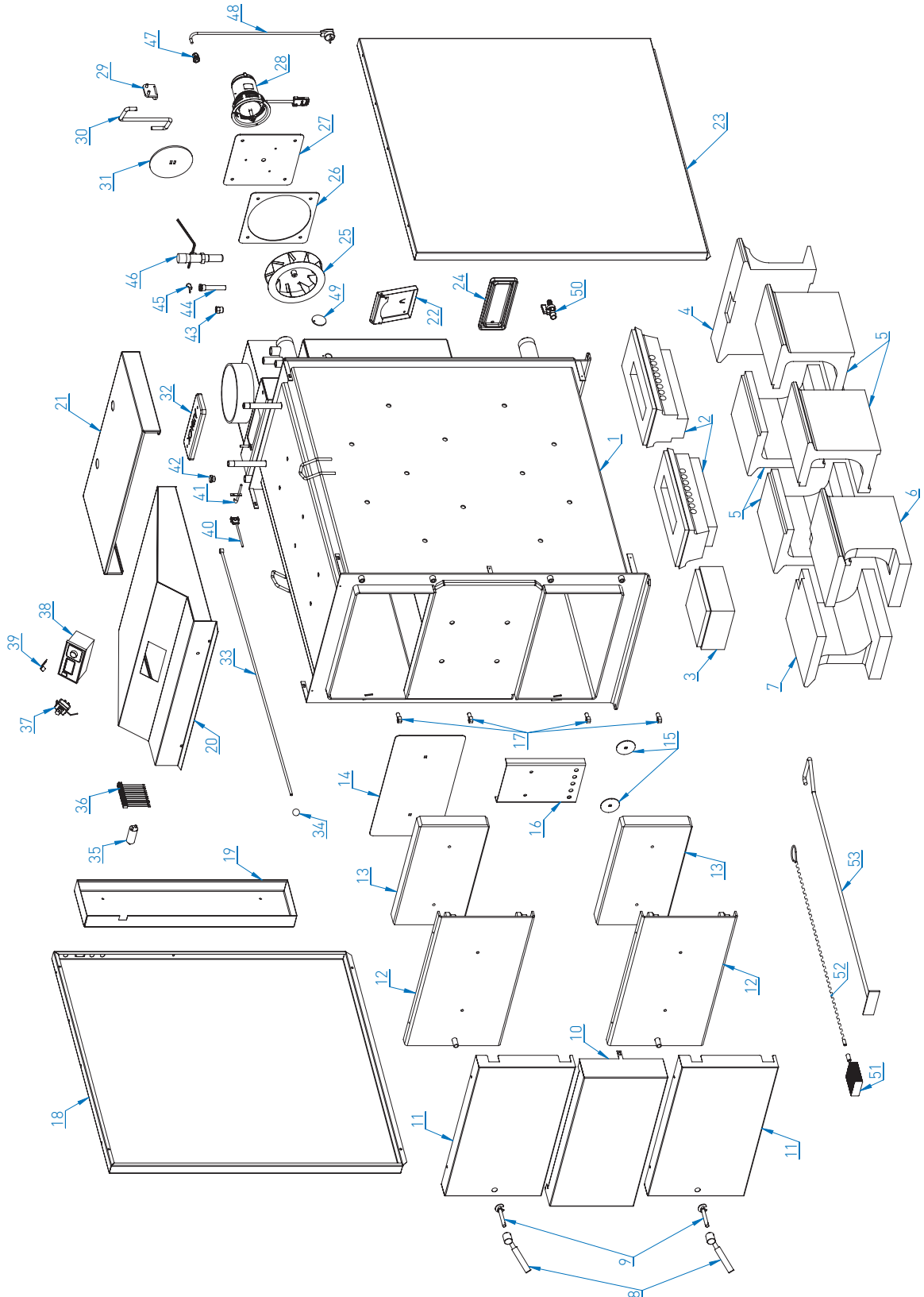

#	CODE	#	CODE
1	DP75003	28	DPD75002E
2	DPT95002A	29	DPV25530
3	DPT95003	30	DPV25074D
4	DPP951088	31	DPV25089B
5	DPP95107B	32	DPV25102B
6	DPP95105B	33	DPV95100
7	DPP95106B	34	DPD25069
8	DPD25420	35	DPD75002B
9	DPD25430	36	DPD15030
10	DP075011	37	OT19C
11	DP075001	38	DPD25073
12	DPV75027	39	DPD25034
13	DPD95002	40	DPD45120
14	DPV75047	41	DPD25059
15	DPV95086	42	DPD25029
16	DPV75031	43	OT11
17	DPV75046	44	DPD25011
18	DP075005A	45	TS106
19	DPV75030	46	OT39C
20	DP075030	47	TS094A
21	DP075009	48	TS091E
22	DPV25101A	49	DPV25041
23	DP075006	50	TS103
24	DPV25102A	51	SM45
25	DPD75003	52	DPC25009
26	DPD75001A	53	DPC75001
27	DPV75015		

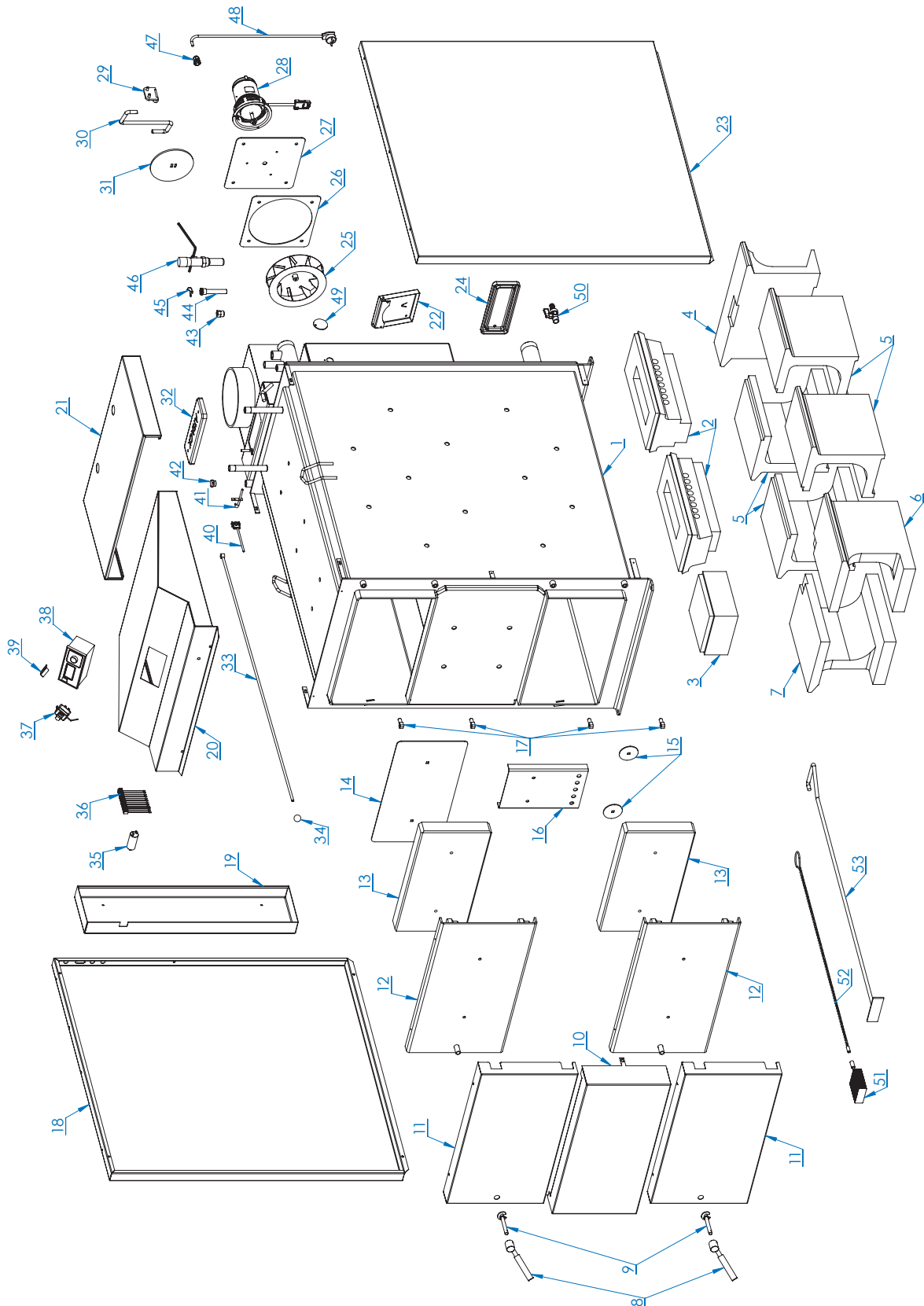

#	CODE	#	CODE
1	DPV75003	31	DPV25089B
2	DPT95002A	32	DPV25102B
3	DPT95003	33	DPV95100
4	DPP95108B	34	DPD25069
5	DPP95107B	35	DPD75002B
6	DPP95105B	36	DPD25027
7	DPP95106B	37	OT19C
8	DPD25420	38	TH05A
9	DPD25430	39	TH06
10	DP075011	40	TS095A
11	DP075001	41	DPD25007B
12	DPV75027	42	DPD25008A
13	DPD95002	43	DPD25010
14	DPV75047	44	DPD25009A
15	DPV95086	45	TS099A
16	DPV75031	46	DPD45120
17	DPV75046	47	DPD25061
18	DP075005A	48	DPD25029
19	DPV75030	49	OT11
20	DP075010	50	DPD25011
21	DP075009	51	TS106
22	DPV25101A	52	OT39C
23	DP075006	53	TS094A
24	DPV25102A	54	TS091E
25	DPD75003	55	DPV25041
26	DPD75001A	56	TS103
27	DPV75015	57	SM45
28	DPD75002E	58	DPC25009
29	DPV25530	59	DPC75001
30	DPV25074D		

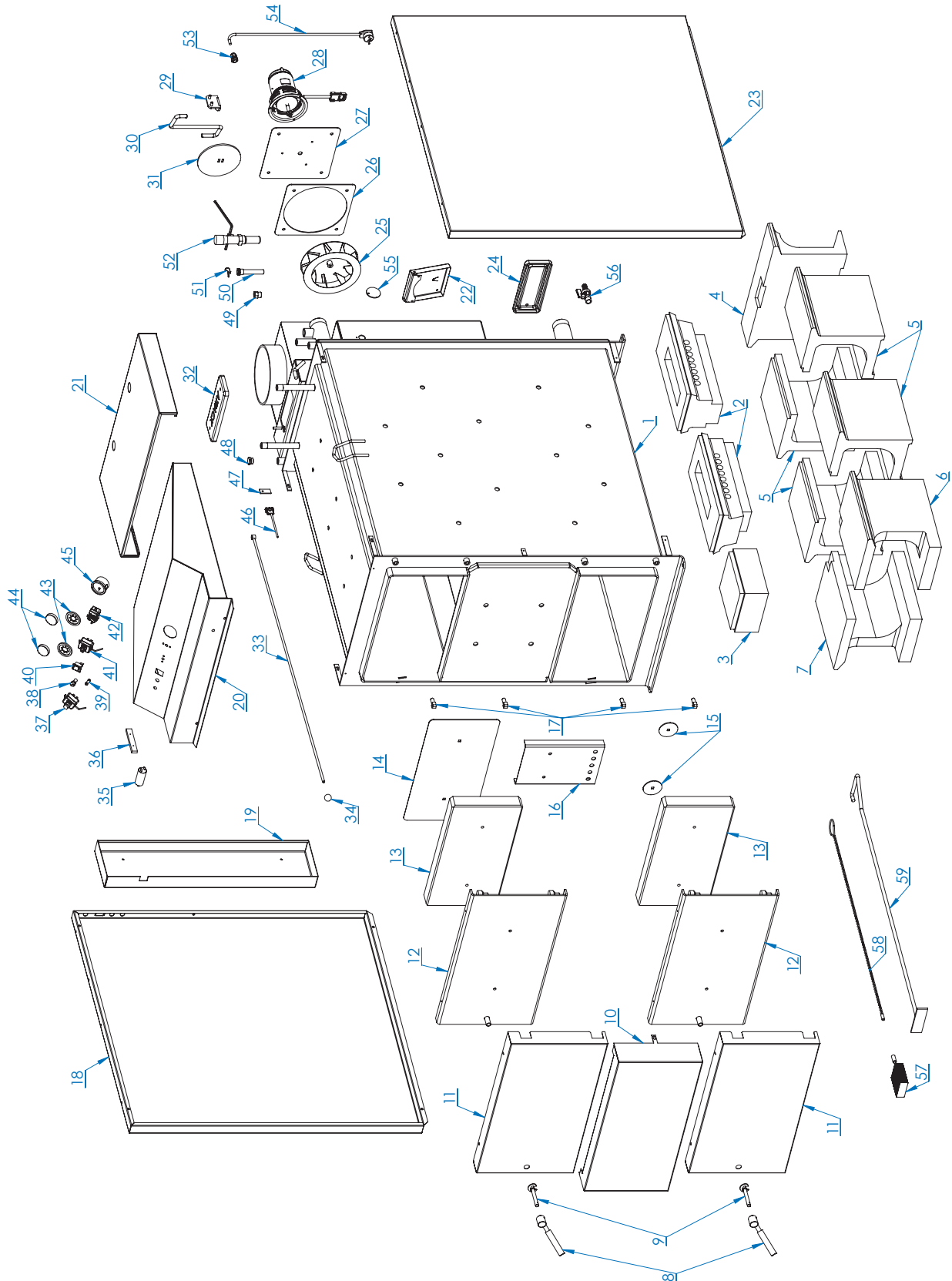

#	CODE	#	CODE
1	DP95003	33	DPV95047A
2	DP195002A	34	DPV95083A
3	DP195003	35	DPV95088
4	DPV95108B	36	DPV95087
5	DPV95107B	37	DPV95089
6	DPV95105B	38	DPO95010A
7	DPV95106B	39	DPV95100
8	DPD25420	40	DPD25069
9	DPD25430	41	TS091E
10	DPO95014	42	DPD95003
11	DPO75001	43	DPD45003
12	DPV75027	44	OT19C
13	DPD95002	45	TH05A
14	DPV75047	46	TH06
15	DPV95086	47	TS095A
16	DPV95011	48	DPD25007B
17	DPV75046	49	DPD25008A
18	DPO95017	50	TS099A
19	DPV95037	51	DPD25010
20	DPO95030	52	DPD25009A
21	DPO95015	53	TS094A
22	DPV25101A	54	DPD45120
23	DPO95001	55	DPD25029
24	DPV95085	56	OT11
25	DPD95010	57	DPD25011
26	DPO95010	58	TS106
27	DPD95909A	59	OT39C
28	DPD95001A	60	TS103
29	DPV95025	61	SM45
30	DPD45001D	62	DPC25009
31	DPV95104	63	DPC75001
32	DPV95201		

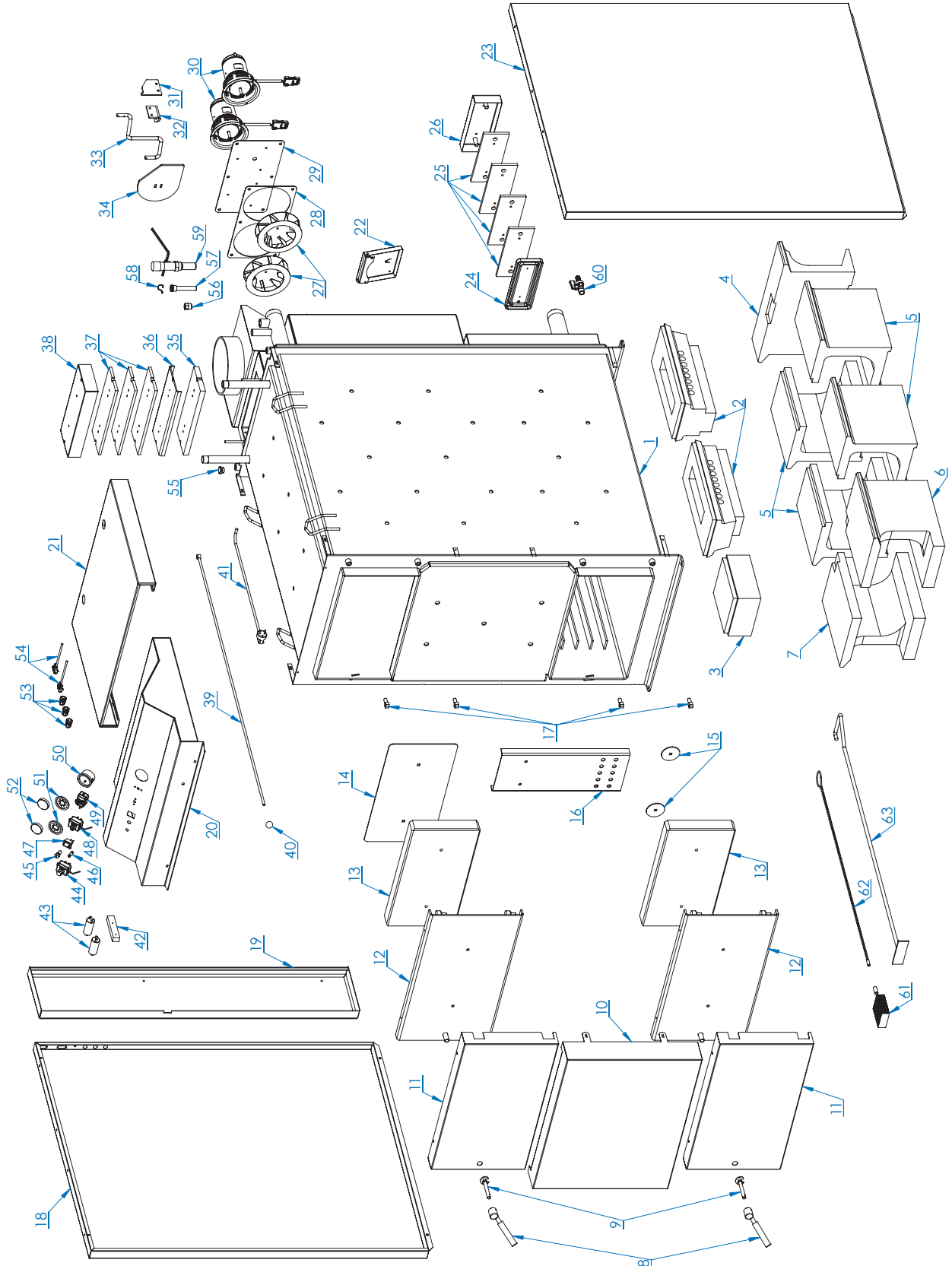

#	CODE	#	CODE
1	DP95003	30	DPD45001D
2	DPT95002A	31	DPV95104
3	DPT95003	32	DPV95201
4	DPP95108B	33	DPV95047A
5	DPP95107B	34	DPV95083A
6	DPP95105B	35	DPV95088
7	DPP95106B	36	DPV95087
8	DPD25420	37	DPV95089
9	DPD25430	38	DPO95010A
10	DPO95014	39	DPV95100
11	DPO75001	40	DPD25069
12	DPV75027	41	TS091E
13	DPD95002	42	OT19C
14	DPV75047	43	DPD45003
15	DPV95086	44	DPD15030
16	DPV95011	45	DPD25034
17	DPV75046	46	DPD25073
18	DPO95017	47	TS094A
19	DPV95037	48	DPD45120
20	DPO95030	49	DPD25029
21	DPO95015	50	OT11
22	DPV25101A	51	DPD25011
23	DPO95001	52	TS106
24	DPV95085	53	OT39C
25	DPD95010	54	TS103
26	DPO95010	55	SM45
27	DPD95909A	56	DPC25009
28	DPD95001A	57	DPC75001
29	DPV95025		

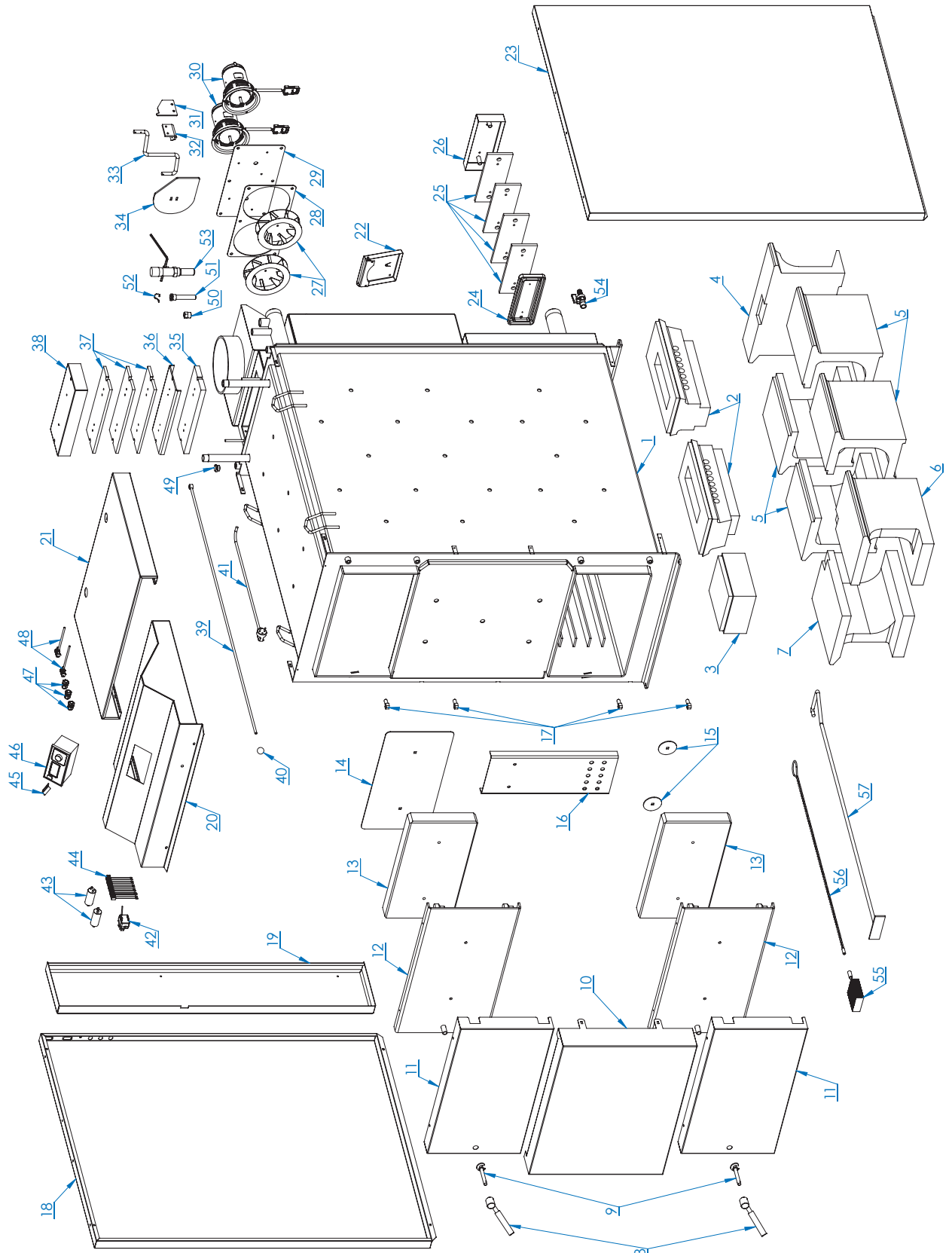



#	CODE	ACKT20	ACKT28
4	504000045	X	
16	521000035	X	X
25	532000070	X	X
33	538000063	X	X
38	545000057	X	X
42	548000062	X	X
46	549000041	X	X
55	240001535	X	X
57	241017828	X	X
104	264100058	X	X
127	538000169	X	X
128	548000176	X	X
130	538000181	X	X
133	545000175	X	X
135	532000180	X	X
137	532000194	X	X
165	532002328	X	X
176	805000010	X	X
223	521000285	X	X
267	521000619	X	X
276	538000652	X	X
322	241009126	X	X
334	241063030	X	X
893	538001567	X	X
894	535001666	X	X
895	538001568	X	X
896	532001658	X	X
898	532001660	X	X
899	532001661	X	X
900	522001665	X	X
901	552001668	X	X
902	500001683	X	X
903	500001684	X	X
904	540001691	X	X
905	540001692	X	X
906	540001693	X	X
907	540001694	X	X
908	540001696	X	X
909	540001697	X	X
911	401120015	X	X

#	CODE	ACKT20	ACKT28
913	538001710	X	X
916	532001712	X	X
918	520001714	X	
919	540001715	X	X
920	540001729	X	X
921	538001732	X	X
923	506001739	X	X
927	242015435	X	X
928	532001747	X	X
929	511001748	X	X
930	241014030	X	X
931	255000011	X	X
932	250100304	X	X
945	510001809	X	X
946	510001810	X	X
947	510001811	X	X
948	550001814	X	X
949	818000001	X	
951	818000003	X	X
952	818000005	X	
953	818000006	X	
954	818000007	X	
955	818000009	X	X
956	818000012	X	X
957	818000014		X
958	818000015		X
959	818000016		X
960	818000018	X	
961	818000019		X
962	532001986	X	X
964	401120011	X	X
967	288148371	X	X
969	802000002	X	X
1169	818000021	X	X
1170	818000022	X	X
1214	520001847		X
1215	818000023		X
1220	504000887		X
1222	803000077	X	X
1405	560001914	X	X
1461	506001954	X	X
1531	506001988	X	X



#	CODE
4	504000045
16	521000035
25	532000070
26	532000071
33	538000063
37	545000056
38	545000057
42	548000062
46	549000041
55	240001535
57	241017828
89	803000002
104	264100058
127	538000169
128	548000176
130	538000181
133	545000175
135	532000180
137	532000194
165	532002328
176	805000010
223	521000285
334	241063030
891	510001538
892	510001539
893	538001567
894	535001666
895	538001568
896	532001658
898	532001660
899	532001661
900	522001665
901	552001668
902	500001683
903	500001684
904	540001691
905	540001692
906	540001693

#	CODE
907	540001694
908	540001696
909	540001697
910	550001700
911	401120015
913	538001710
914	549001711
915	801000003
916	532001712
917	520001713
919	540001715
920	540001729
921	538001732
923	506001739
925	515001744
927	242015435
928	532001747
930	241014030
931	255000011
932	250100304
933	511001765
950	818000002
951	818000003
955	818000009
956	818000012
957	818000014
958	818000015
959	818000016
961	818000019
962	532001986
963	803000075
965	401120012
967	288148371
969	802000002
1169	818000021
1170	818000022
1405	560001914
1461	506001954
1531	506001988

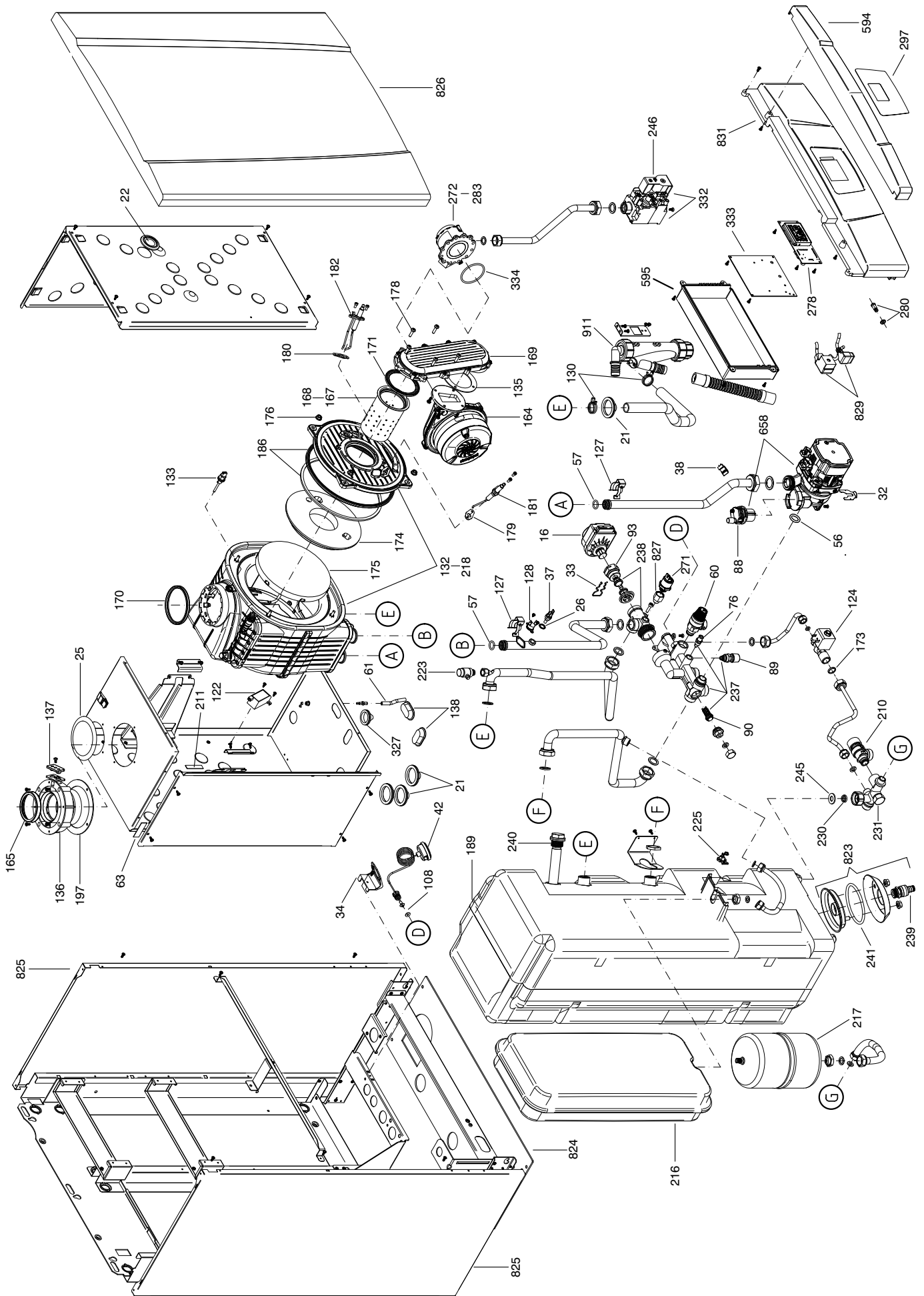

#	CODE
16	521000035
21	532000082
22	532000067
25	532000070
26	532000071
32	538000065
33	538000063
34	540000144
37	545000056
38	545000057
42	548000062
56	241017040
57	241017828
60	255000001
61	264070040
63	280001503
76	511000014
88	802000001
89	803000002
90	803000004
93	803000015
108	235041110
122	552000190
124	521000380
127	538000169
128	548000176
130	538000181
132	520000160
133	545000175
135	532000180
136	540000195
137	532000194
138	532000189
164	535000226
165	532002328
167	805000001
168	805000002
169	805000003
170	805000004
171	805000005
173	533000381
174	805000008
175	805000009
176	805000010
178	805000012

#	CODE
179	805000013
180	805000014
181	805000015
182	805000016
186	401120001
189	525000445
197	532000165
210	255000002
211	280001003
216	504000280
217	504000281
218	520000206
223	521000285
225	545000283
230	521000357
231	510000356
237	803000017
238	803000001
239	803000026
240	809000001
241	809000002
245	235112420
246	808000002
271	549000623
272	565000631
278	552000656
279	552000657
280	540000658
283	565000663
297	552000667
327	532000614
332	522000688
333	552000710
334	241063030
594	540000831
595	540000891
658	250100104
823	809000013
824	500001603
825	500001604
826	500001605
827	511001608
828	500001606
829	550001611
830	540001614
831	540001615
911	401120015



#	CODE	ACKT48	ACKT65
21	532000082	X	X
26	532000071	X	X
37	545000056	X	X
38	545000057	X	X
57	241017828	X	
61	264070040	X	X
88	802000001	X	X
123	803000006	X	X
127	538000169	X	X
128	548000176	X	X
130	538000181	X	X
133	545000175	X	X
135	532000180	X	X
170	805000004	X	X
171	805000005	X	X
175	805000009	X	X
176	805000010	X	X
178	805000012	X	X
179	805000013	X	X
180	805000014	X	X
186	401120001	X	X
246	808000002	X	X
254	500000556	X	X
255	540000558	X	X
256	540000559	X	X
271	549000623	X	X
276	538000652	X	X
278	552000656	X	X
279	552000657	X	X
280	540000658	X	X
294	500000561	X	X
295	540000570	X	X
296	540000589	X	X
297	552000667	X	X
322	241009126	X	X
326	250100404	X	
332	522000688	X	X
495	532000724	X	X
496	500000794	X	X
497	560000850	X	X
498	560000849	X	X

#	CODE	ACKT48	ACKT65
499	500000795	X	X
500	560000851	X	X
501	565000806	X	
502	565000807		X
503	241069835	X	X
504	532000960	X	
505	532000962		X
506	552000859	X	X
507	520000735	X	
508	520000784		X
509	535000738	X	
510	535000739		X
511	511000754	X	X
512	538000170	X	X
513	521000860	X	X
515	540000846	X	X
516	532000809	X	X
517	255000003	X	X
518	241019031		X
519	511000853	X	X
520	250112501		X
521	540000740	X	X
522	540000759	X	X
523	550000841	X	X
524	552000890	X	X
528	805000019	X	X
529	805000020	X	X
530	805000021	X	
531	805000022		X
532	805000023	X	X
533	805000024	X	X
536	540000886	X	X
534	565001055	X	
535	565001056		X
537	560000852	X	X
626	500001052	X	X
627	540001053	X	
628	540001054		X
633	510000799	X	X
660	250100405	X	
676	550001337	X	
1531	506001988	X	X



#	CODE	ACKT85	ACKT110
26	532000071	X	X
37	545000056	X	X
61	264070040	X	X
123	803000006	X	X
128	548000176	X	X
135	532000180	X	X
171	805000005	X	X
176	805000010	X	X
179	805000013	X	X
180	805000014	X	X
223	521000285	X	X
278	552000656	X	X
279	552000657	X	X
280	540000658	X	X
297	552000667	X	X
495	532000724	X	X
503	241069835	X	X
505	532000962	X	X
506	552000859	X	X
510	535000739	X	
513	521000860	X	X
516	532000809	X	X
521	540000740	X	X
524	552000890	X	X
532	805000023	X	X
533	805000024	X	X
544	533000172	X	X
569	500000828	X	X
570	560000865	X	X
571	500000829	X	X
572	560000864	X	X
573	500000808	X	X
574	560000866	X	X
575	511000811	X	X
576	240000134	X	X
577	522000810	X	X
578	565001173	X	
579	540001079	X	
580	520000786	X	

#	CODE	ACKT85	ACKT110
581	545001081	X	X
582	511001082	X	X
583	560000921	X	
584	560000922	X	
585	560000832	X	X
586	560000833	X	X
587	540000848	X	X
588	540001083	X	X
589	549001087	X	X
590	255000007	X	X
591	250112601	X	X
592	545001084	X	X
593	540000919	X	
594	540000831	X	X
595	540000891	X	X
596	552001088	X	X
597	550000842	X	X
598	540000830	X	X
599	511001089	X	X
600	565000867	X	
601	565000868		X
602	565001182		X
603	540001086		X
604	560000834		X
605	560000835		X
606	535000812		X
607	540000920		X
609	808000003	X	X
610	808000004	X	X
611	805000025	X	X
612	805000026	X	X
613	805000028	X	X
614	805000029	X	X
615	805000030	X	X
616	805000031	X	X
618	805000033	X	X
621	401120005	X	X
622	520000790		X
623	500001178	X	X
624	540001177	X	X
625	401120006	X	X



#	CODE
26	532000071
37	545000056
61	264070040
123	803000006
128	548000176
135	532000180
171	805000005
176	805000010
179	805000013
180	805000014
223	521000285
278	552000656
279	552000657
280	540000658
297	552000667
495	532000724
506	552000859
513	521000860
516	532000809
521	540000740
524	552000890
532	805000023
533	805000024
544	533000172
571	500000829
572	560000864
575	511000811
576	240000134
581	545001081
582	511001082
585	560000832
586	560000833
587	540000848
588	540001083
589	549001087

590	255000007
592	545001084
594	540000831
595	540000891
596	552001088
598	540000830
599	511001089
607	540000920
611	805000025
612	805000026
613	805000028
615	805000030
616	805000031
618	805000033
621	401120005
623	500001178
624	540001177
625	401120006
634	505000857
712	500001396
713	500001397
714	560001400
715	560001401
716	560001402
717	560001403
718	500001404
719	520001405
720	511001411
721	511001412
722	532001415
723	250112602
724	522001478
725	522001414
726	550001410
889	535001818
1391	821000001
1470	805000037

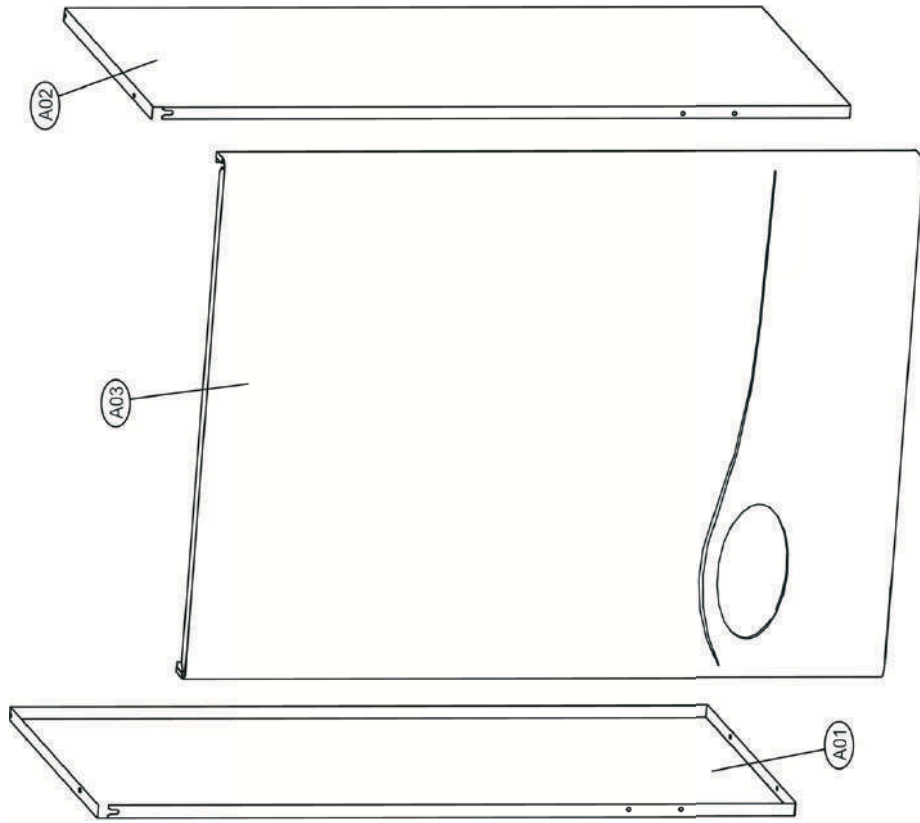

#	CODE
A01	PLA56
A02	PLA57
A03	PLA58

# ATTACK KZT Plus

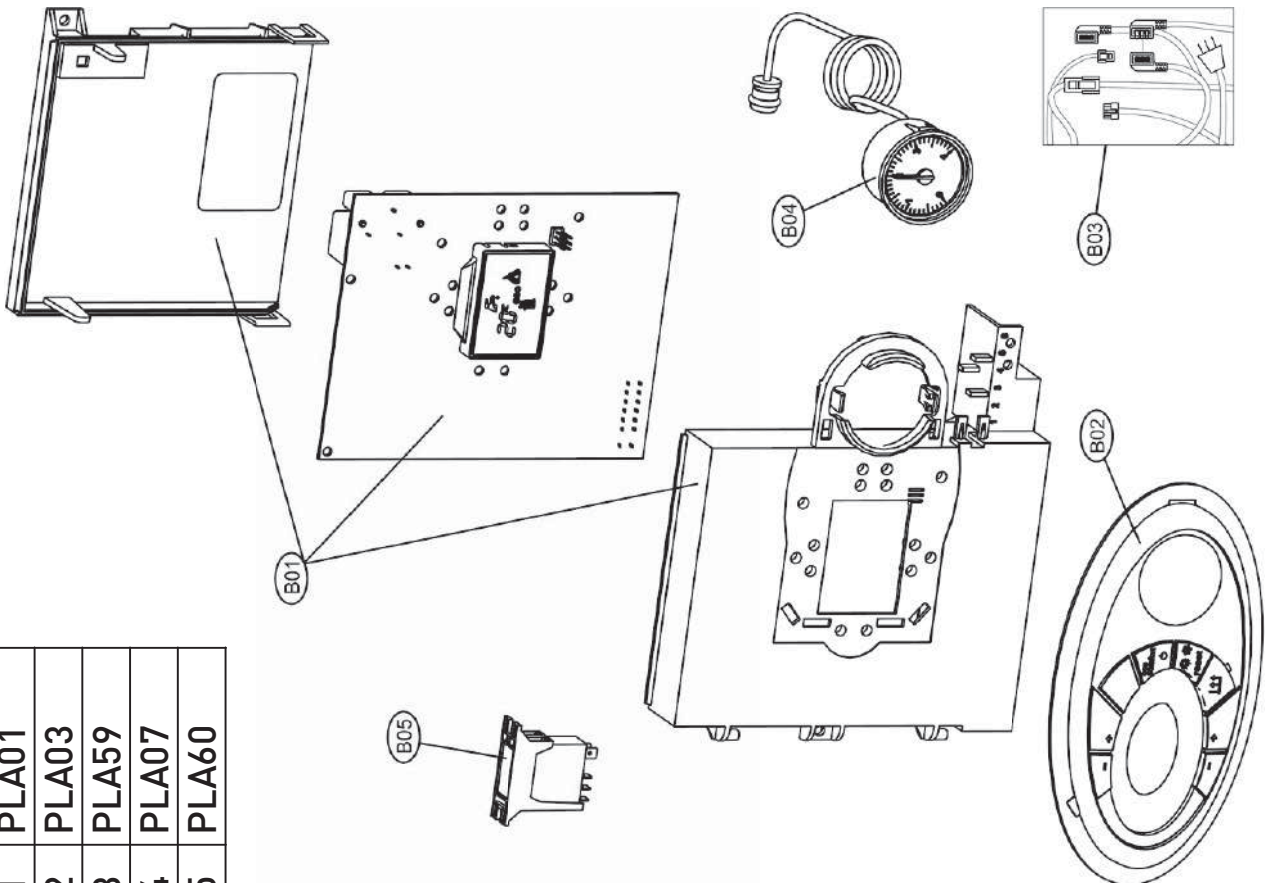

#	CODE
B01	PLA01
B02	PLA03
B03	PLA59
B04	PLA07
B05	PLA60

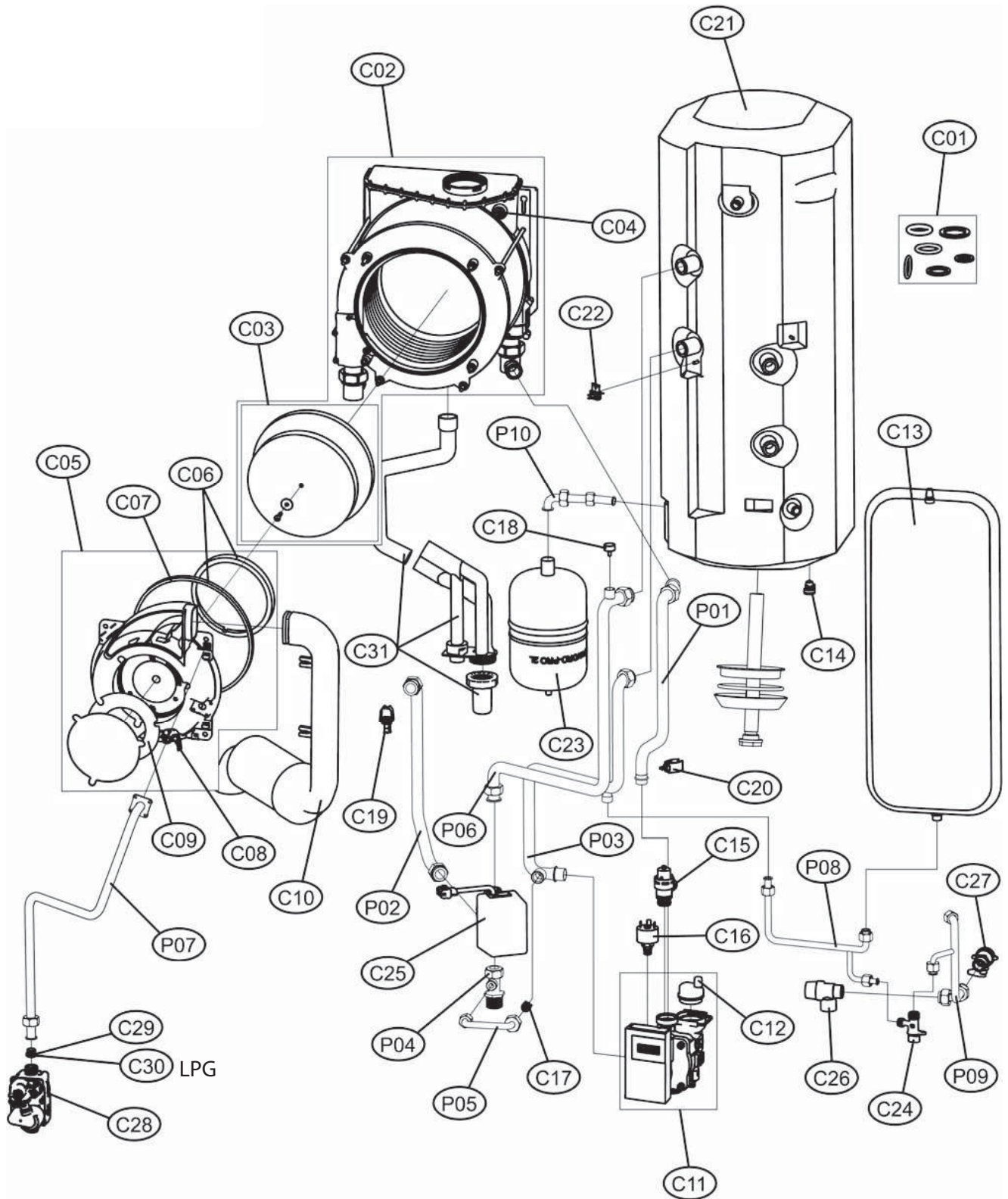

#	CODE	#	CODE	#	CODE	#	CODE	#	CODE
C01	PLA08	C10	PLA19	C18	PLA26	C26	PL81	P03	PLA37
C02	PLA11	C11	PLA61	C19	PL77	C27	PL108	P04	PLA41
C03	PLA12	C12	PL29	C20	PL23	C28	PLA29	P05	PLA42
C04	PLA13	C13	PLA21	C21	PLA28	C29	PLA62	P06	PLA46
C05	PLA14	C14	PL107	C22	PL25	C30	PLA30	P07	PLA47
C06	PLA15	C15	PL26	C23	PL76	C31	PLA63	P08	PLA48
C07	PLA16	C16	PL27	C24	PLA23	P01	PLA33	P09	PLA49
C08	PLA17	C17	PL37	C25	PLA32	P02	PLA36	P10	PLA50
C09	PLA18								

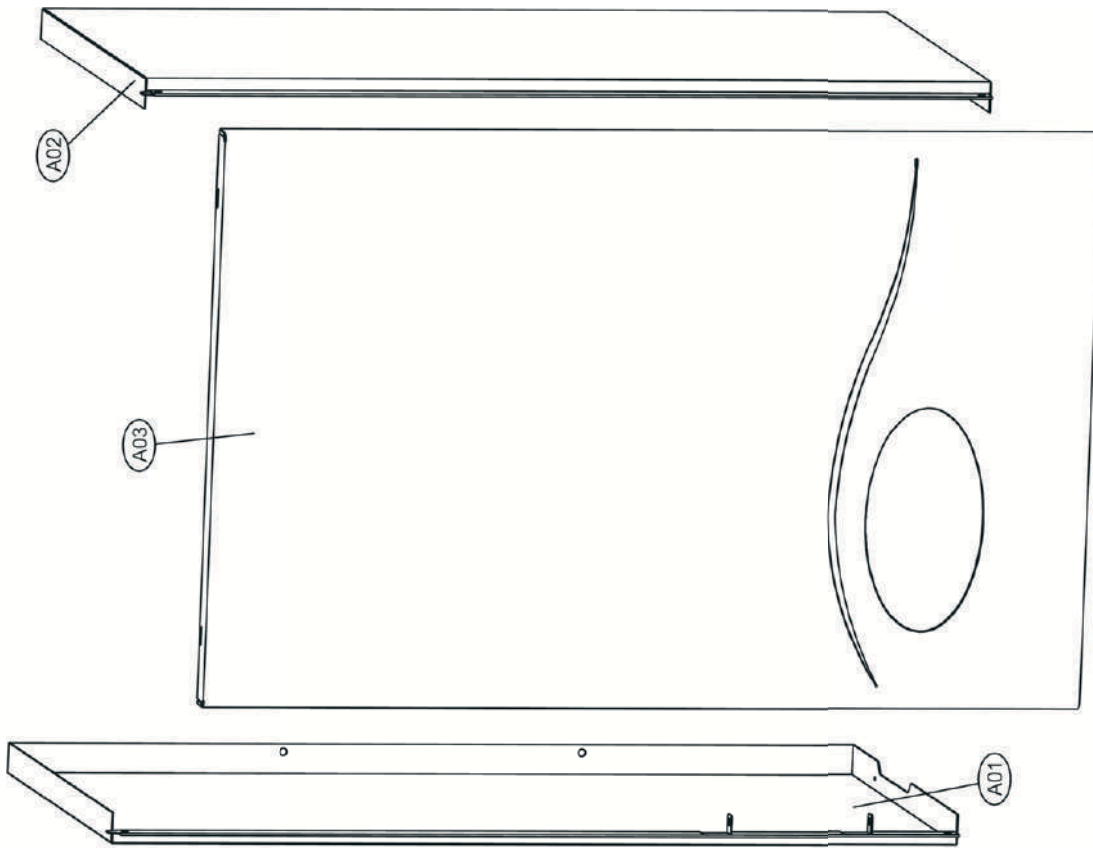

#	CODE
A01	PLA64
A02	PLA65
A03	PLA66

# ATTACK KST Plus

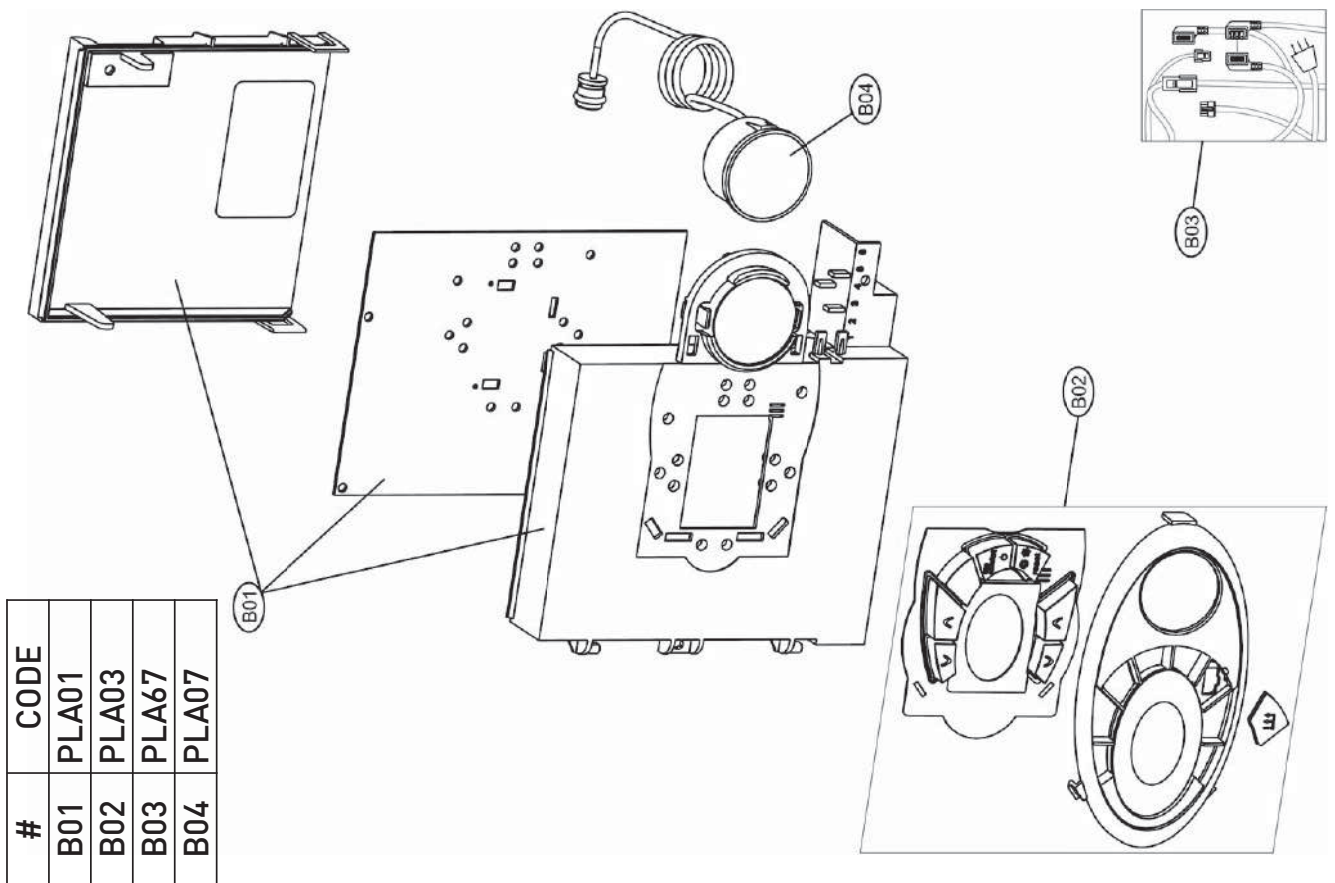

#	CODE
B01	PLA01
B02	PLA03
B03	PLA67
B04	PLA07

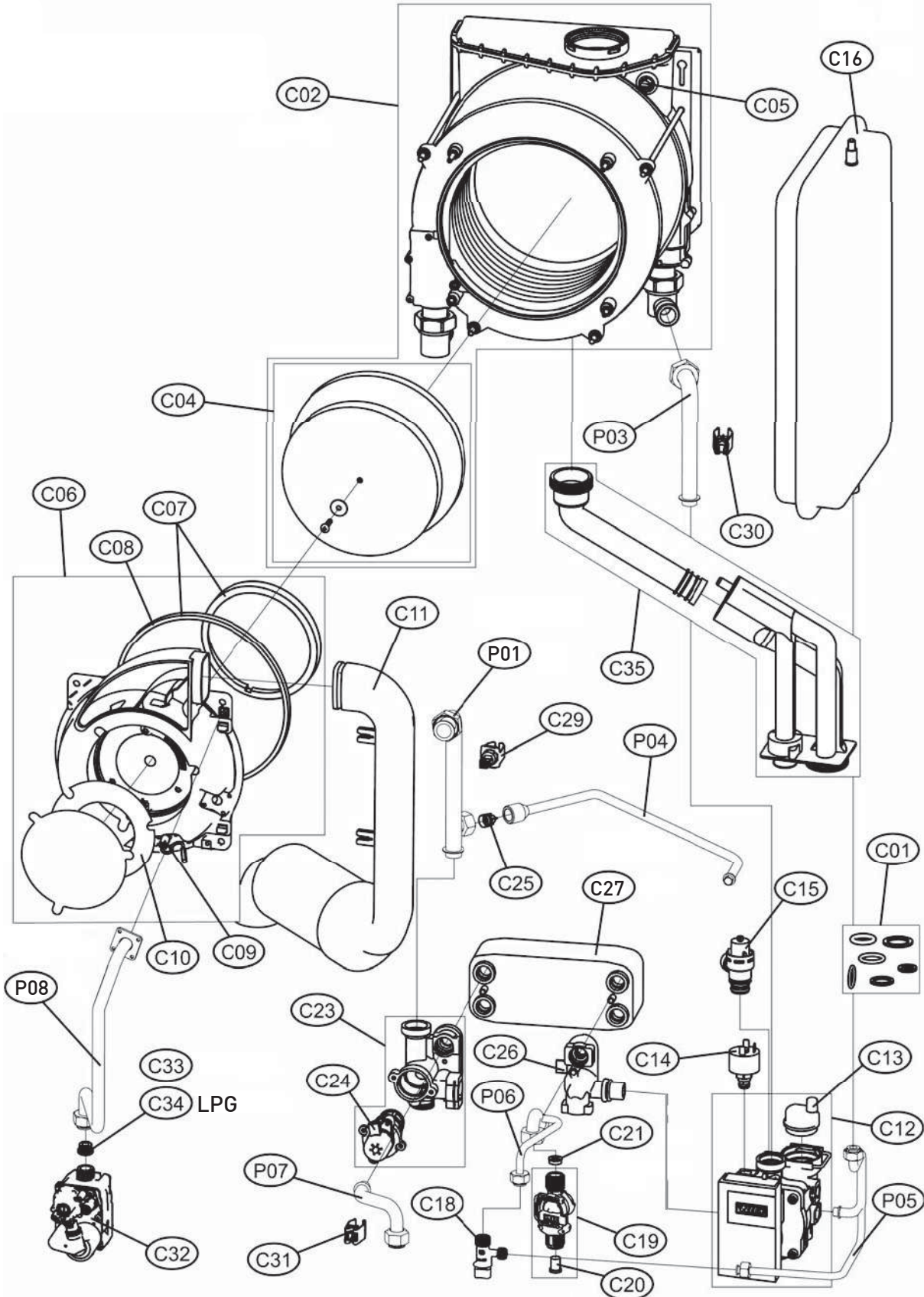

#	CODE	#	CODE	#	CODE	#	CODE	#	CODE
C01	PLA68	C10	PLA18	C19	PLA24	C29	PL77	P01	PLA40
C02	PLA11	C11	PLA19	C20	PLA25	C30	PL23	P03	PLA35
C04	PLA12	C12	PLA61	C21	PL82	C31	PL24	P04	PLA38
C05	PLA13	C13	PL29	C23	PL31	C32	PLA29	P05	PLA40
C06	PLA14	C14	PL27	C24	PL295	C33	PLA62	P06	PLA43
C07	PLA15	C15	PL26	C25	PL37	C34	PLA30	P07	PLA45
C08	PLA16	C16	PLA22	C26	PL288	C35	PLA63	P08	PLA44
C09	PLA17	C18	PLA23	C27	PL289				

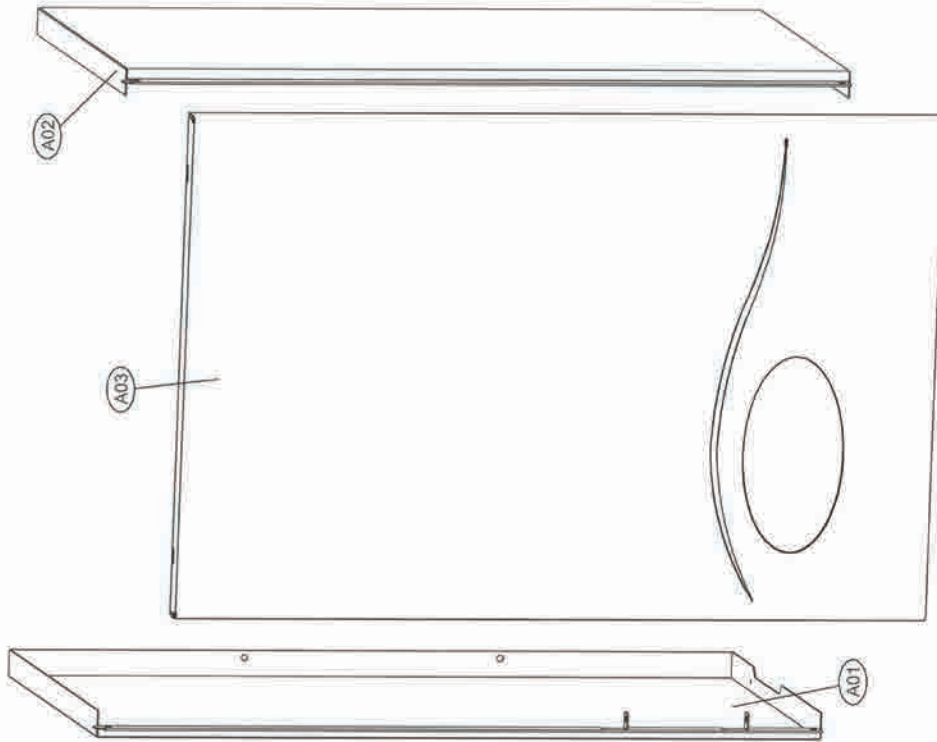

#	CODE
A01	PLA64
A02	PLA65
A03	PLA66

# ATTACK KT Plus, KT Small Plus

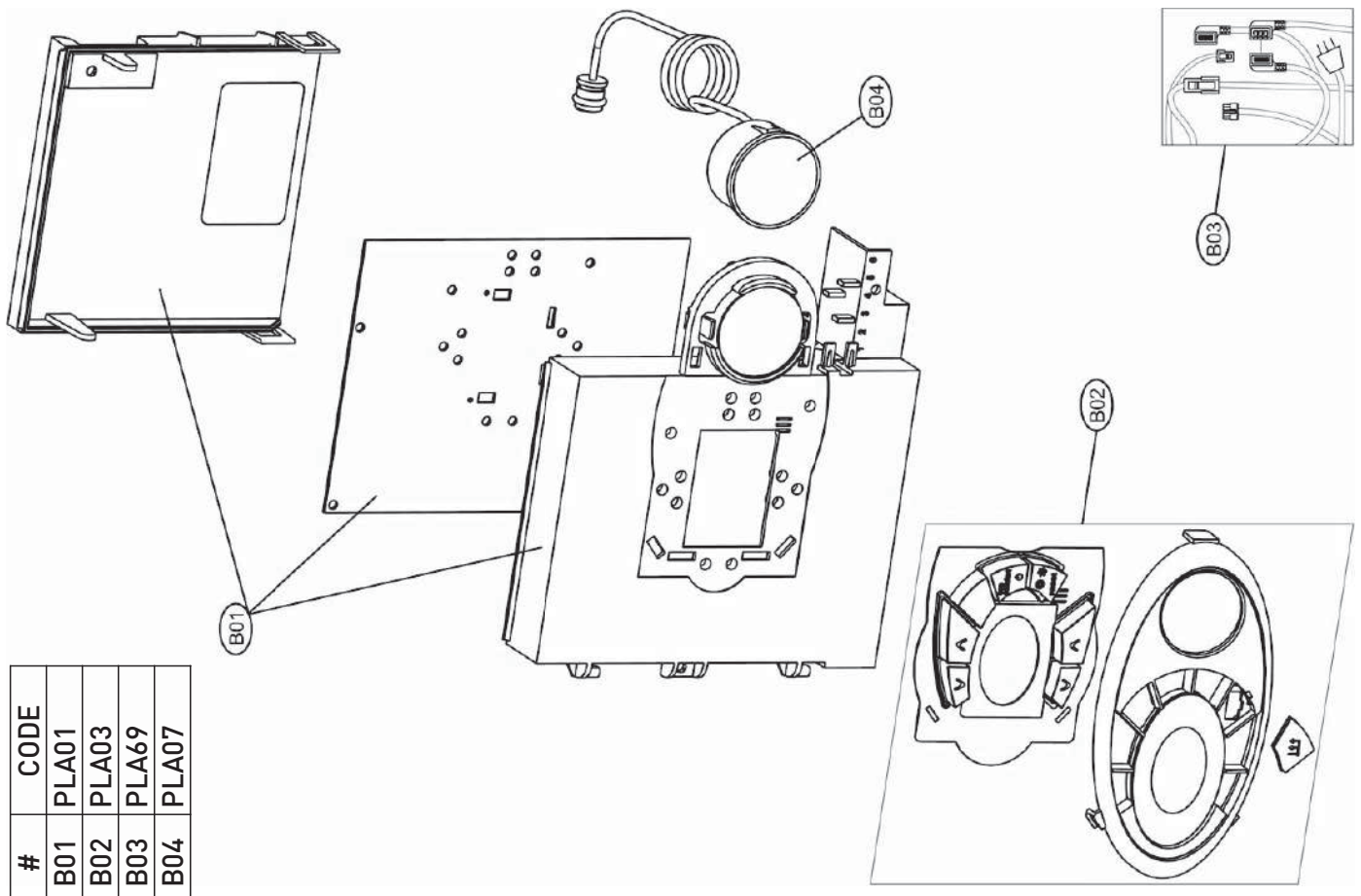

#	CODE
B01	PLA01
B02	PLA03
B03	PLA69
B04	PLA07

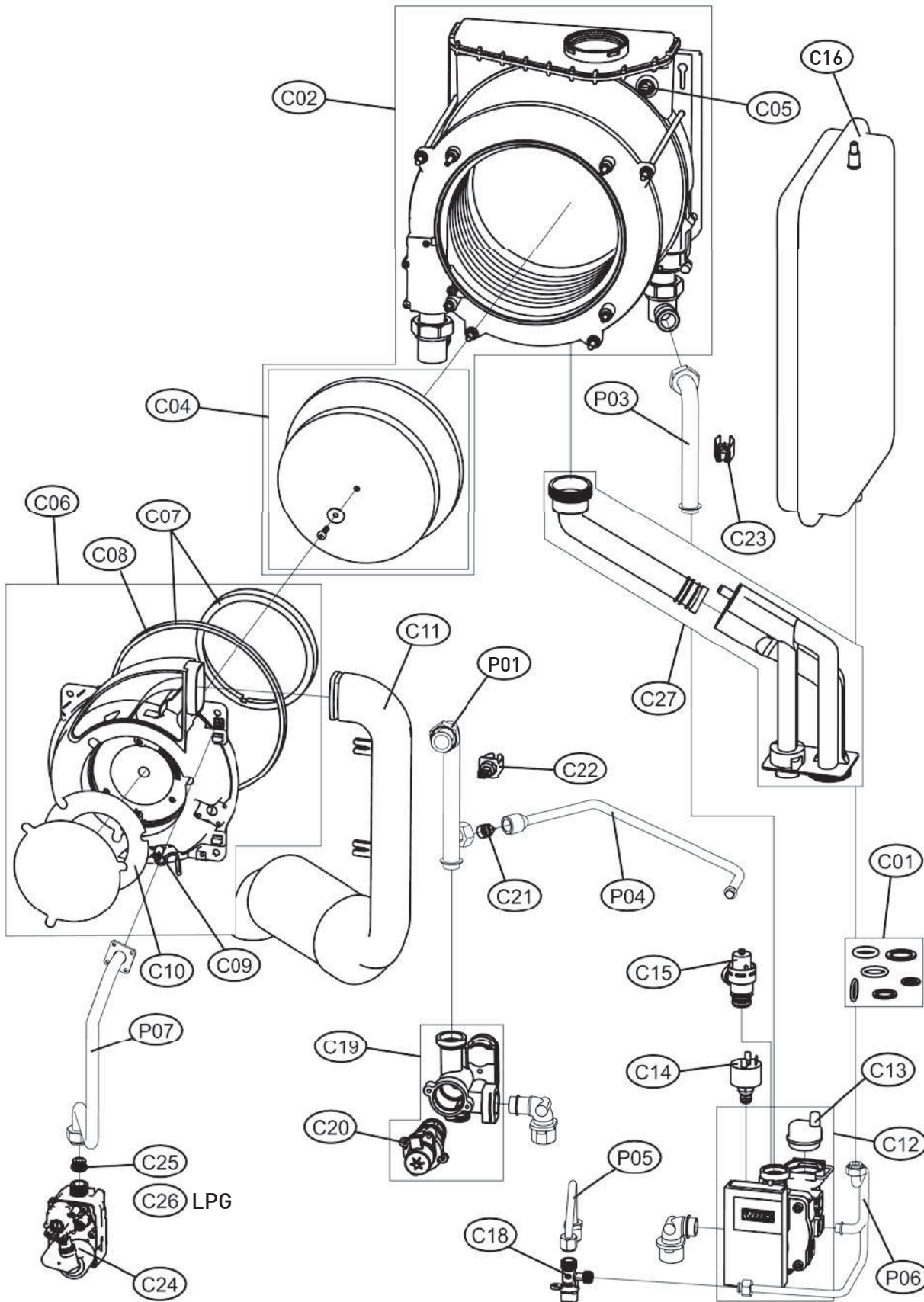

#	CODE
C01	PLA09
C02	PLA11
C04	PLA12
C05	PLA13
C06	PLA14
C07	PLA15
C08	PLA16
C09	PLA17
C10	PLA18
C11	PLA19
C12	PLA61
C13	PL29
C14	PL27
C15	PL26
C16	PLA22
C18	PLA23
C19	PL30
C20	PL295
C21	PL37
C22	PL77
C23	PL23
C24	PLA29
C25	PLA62
C26	PLA30
C27	PLA63
P01	PLA34
P03	PLA35
P04	PLA38
P05	PLA39
P06	PLA40
P07	PLA44

#	CODE	[kW]	#	CODE	[kW]
1	TS001D	15-30	18		
2	TS002B	15-30	19	TS067B	15-30
3	TS008A	15, 20	20	TS068	15-30
4	TS009	25, 30	21	TS555	15-30
5	TS013	15, 20	22	TS556	15-30
6	TS014	25, 30	23	TS557	15-30
7	TS535	15, 20	24	TS554	15-30
8	TS536	25, 30	25	TS080	15, 20
9	TS538	15, 20		TS079	25, 30
10	TS540	25, 30	26	TS080A	15, 20
11	TS024	15, 20		TS079A	25, 30
12	TS025	25, 30	27	TS081	15, 20
13	TS035C	15, 20		TS082	25, 30
14	TS036B	25, 30	28	TS224	15, 20
15	TS041C	15, 20		TS223	25, 30
16	TS042C	25, 30	29	OT11	15-30
17	TS030C	15, 20	30	TS102	15-30
	TS031C	25, 30	31	TS106	15-30
11	TS047	15, 20	32	TH27A	15
	TS048	25, 30		TS215	15-30
12	TS083	15-30	33	RZ21	15-30
13	TS220	15, 20	34	RZ41A	15-30
14	TS221	25, 30	35	RZ22	15-30
	TS087	15, 20	36	TS099	15-30
	TS088	25, 30	37	TS095	15-30
15	TS062	15, 20	38	RZ21A	15-30
	TS063	25, 30	39	HV65	15-30
15.1	TS146	15-30	40	TS091	15-30
15.2	TS147	15-30	41	TS107	15-30
15.3	TS145	15-30	42	TS122	15-30
15.4	SR47B	15-30	43	TS123	15-30
16	TS052	15, 20	44	TS094	15-30
	TS053	25, 30	45	TS103	15-30
	TS140A	15, 20			
	TS140B	25, 30			

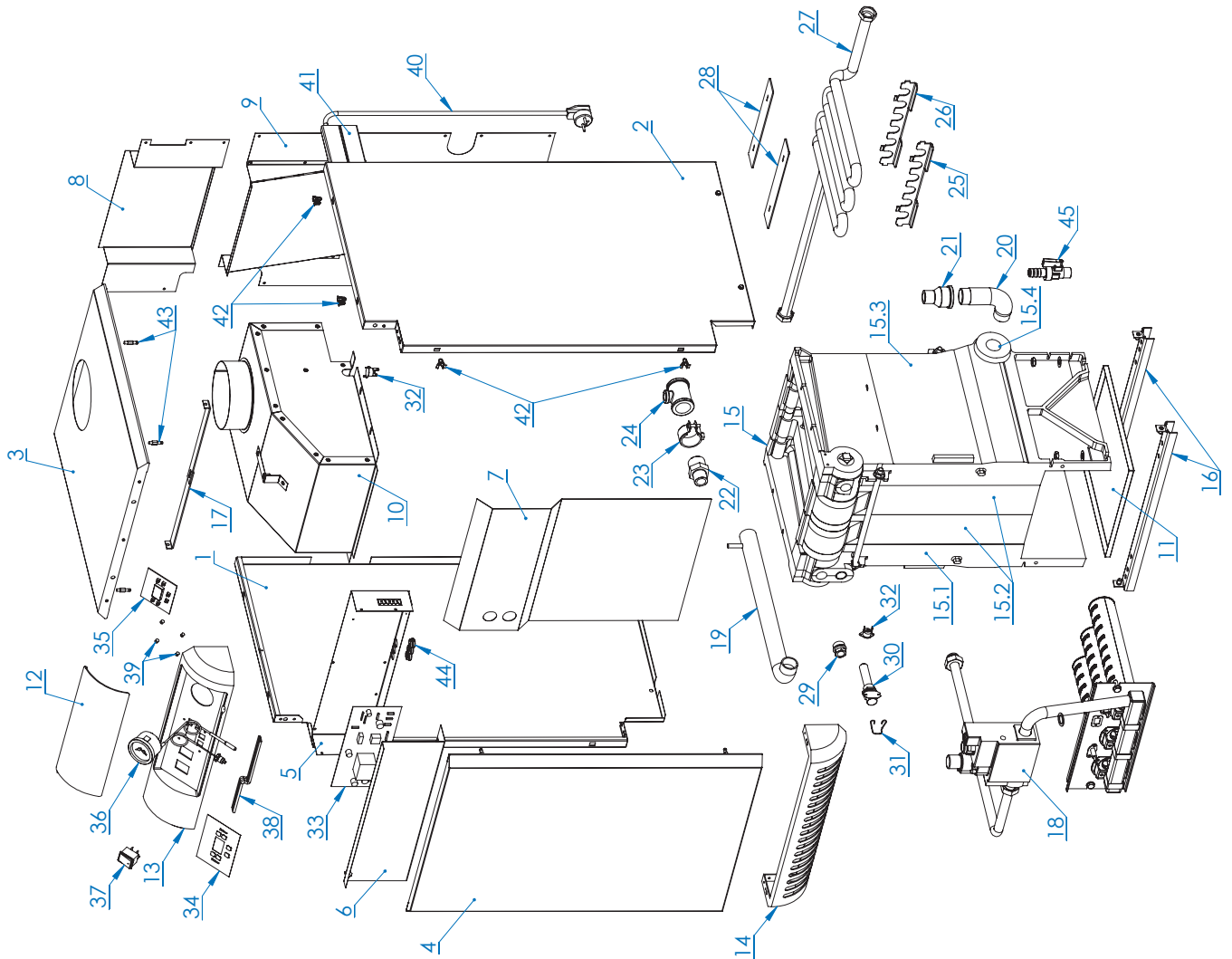

#	CODE	[kW]
18.1	AU4105MR	15-30
18.2	AU4100T	15-30
18.3	AT56	15-30
18.4	HZ05	15, 20
	HZ07	25, 30
18.5	HZ93	15, 20
	HZ87	25, 30
18.6	HZ01	15-30
18.7	HZ71A	15, 20
	HZ72B	25, 30
18.8	HZ26B	15-30
18.9	AT20A	15-30
18.10	HZ132	15-30
18.11	HZ130	15-30
18.12	HZ131	15-30
18.13	HZ81A	15, 20
	HZ82A	25, 30
18.14	HZ33	15, 25
	HZ34	20, 30
18.15	HZ49	15-30

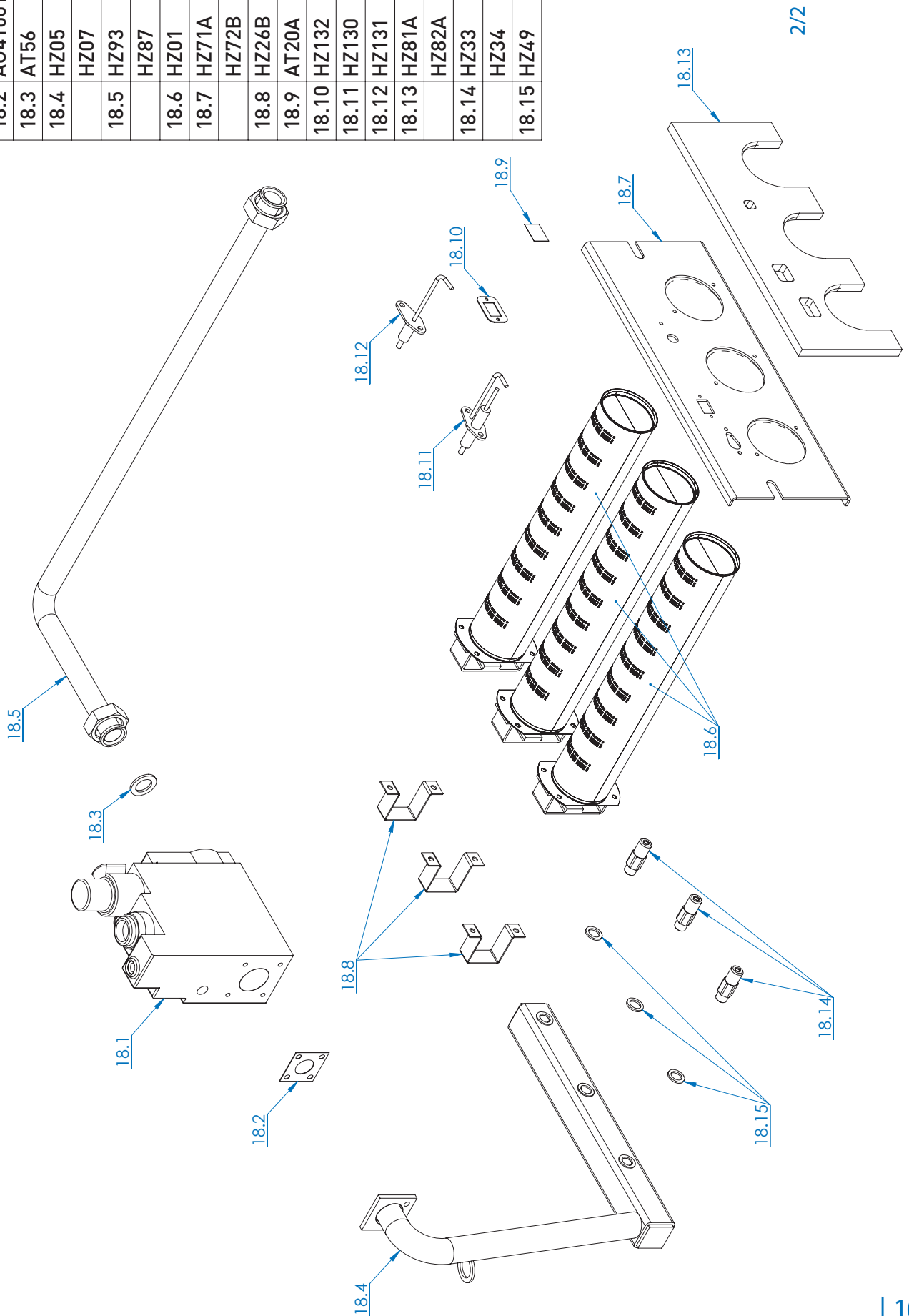

2/2

#	CODE	KW
1	SM103	15, 20
	SM104	25, 30
1.1	SM108	
1.2	SM109	
1.3	SM110	
2	PAGE 103	
3	TS653	15, 20
	TS599	25, 30
4	TS923	15, 20
	TS930	25, 30
5	TS102	
6	TS215B	
7	TS106	
8	OT11	
9	HZ218	
10	TS659	
11	TS600	
12	TS655	
13	TS656	
14	TS657	
15	TS654	
16	TS616	
17	TS617	
18	HZ226	15, 20
	HZ227	25, 30
19	TH27A	15
	TS215B	20, 25, 30
20	RZ21A	
21	TS091	
22	TS083	
23	TS225	15, 20
	TS226	25, 30
24	TS569	15, 20
	TS568	25, 30
25	TS603	15, 20
	TS614	25, 30
26	TS934A	15, 20
	TS933A	25, 30
27	TS632	
28	HZ205	15, 20
	HZ200	25, 30
29	TS607	
30	TS608	
31	TS609	15, 20
	TS601	25, 30
32	TS611	15, 20
	TS606	25, 30
33	TS535	15, 20
	TS536	25, 30
34	TS538	15, 20
	TS540	25, 30
35	TS141A	15, 20
	TS141	25, 30
36	RZ24	
37	TH16	
38	TS095	
39	TS099	
40	RZ41C	
41	HV65	
42	RZ23	
43	TS197A	
44	TH44	

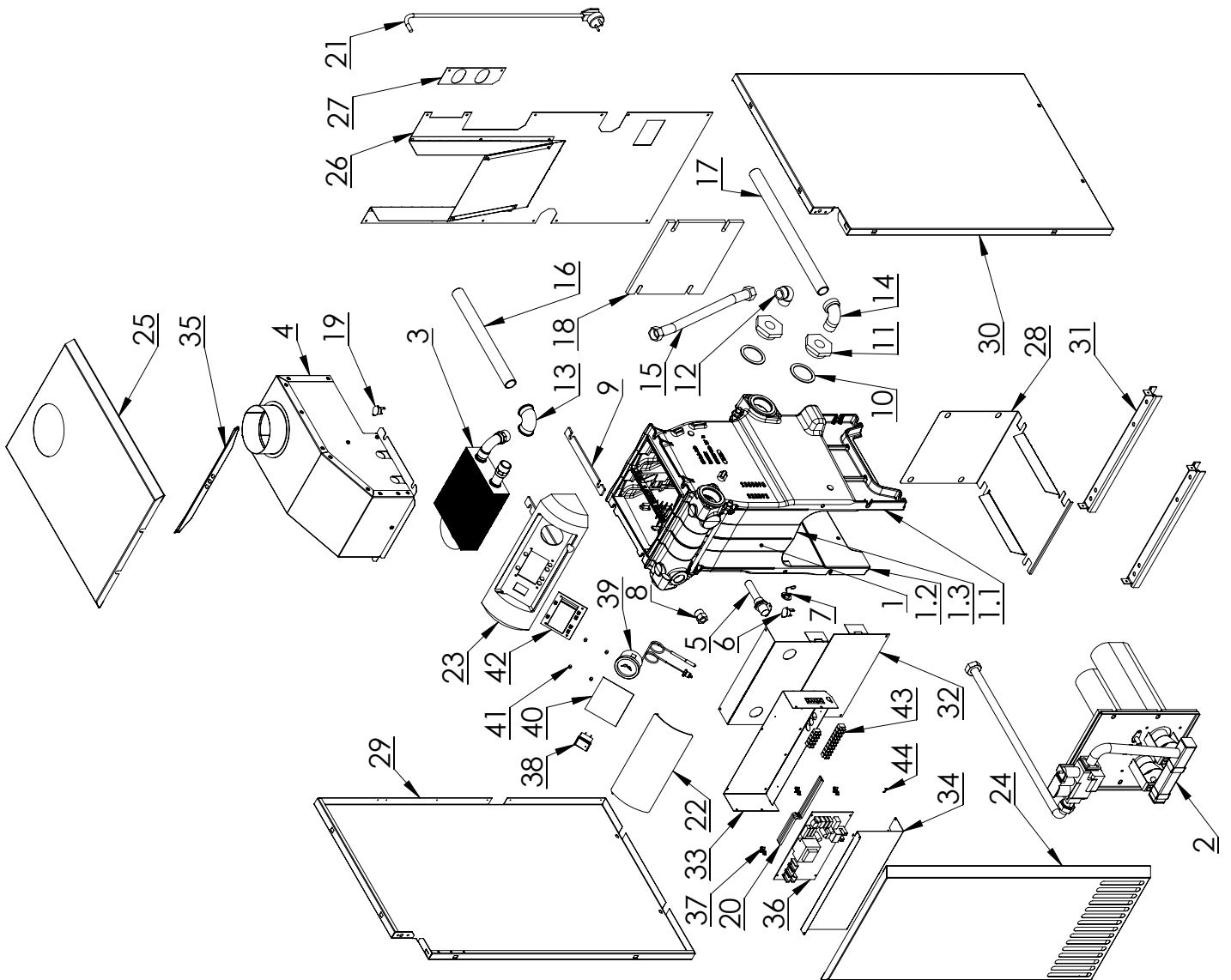

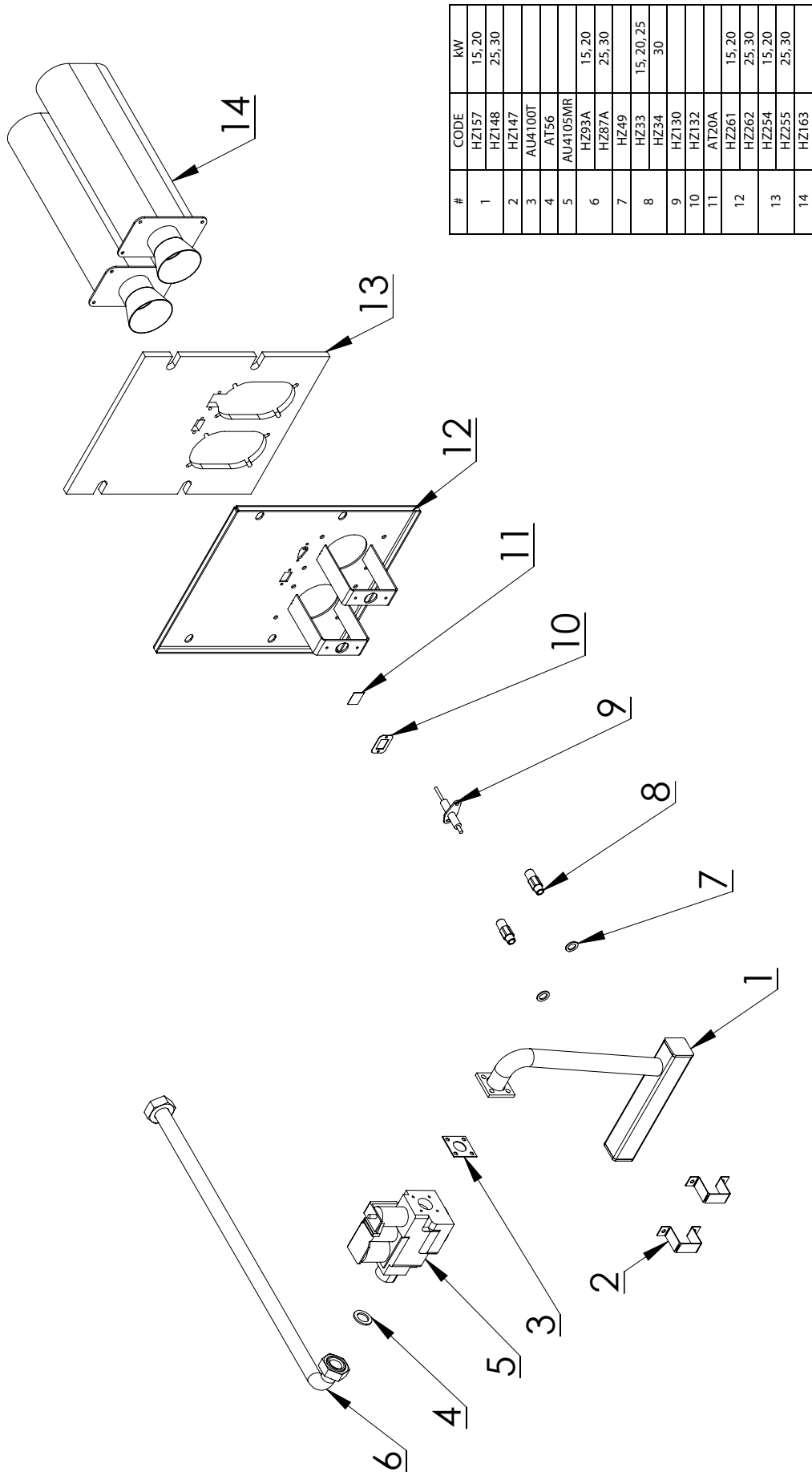

#	CODE	RW
1	HZ157	15, 20
2	HZ148	25, 30
3	HZ147	
4	AU4100T	
5	AT156	
6	AU4105MR	
7	HZ93A	15, 20
8	HZ87A	25, 30
9	HZ49	15, 20, 25
10	HZ33	15, 20, 25
11	HZ34	30
12	HZ130	
13	HZ132	
14	AT20A	
15	HZ261	15, 20
16	HZ262	25, 30
17	HZ254	15, 20
18	HZ255	25, 30
19	HZ163	

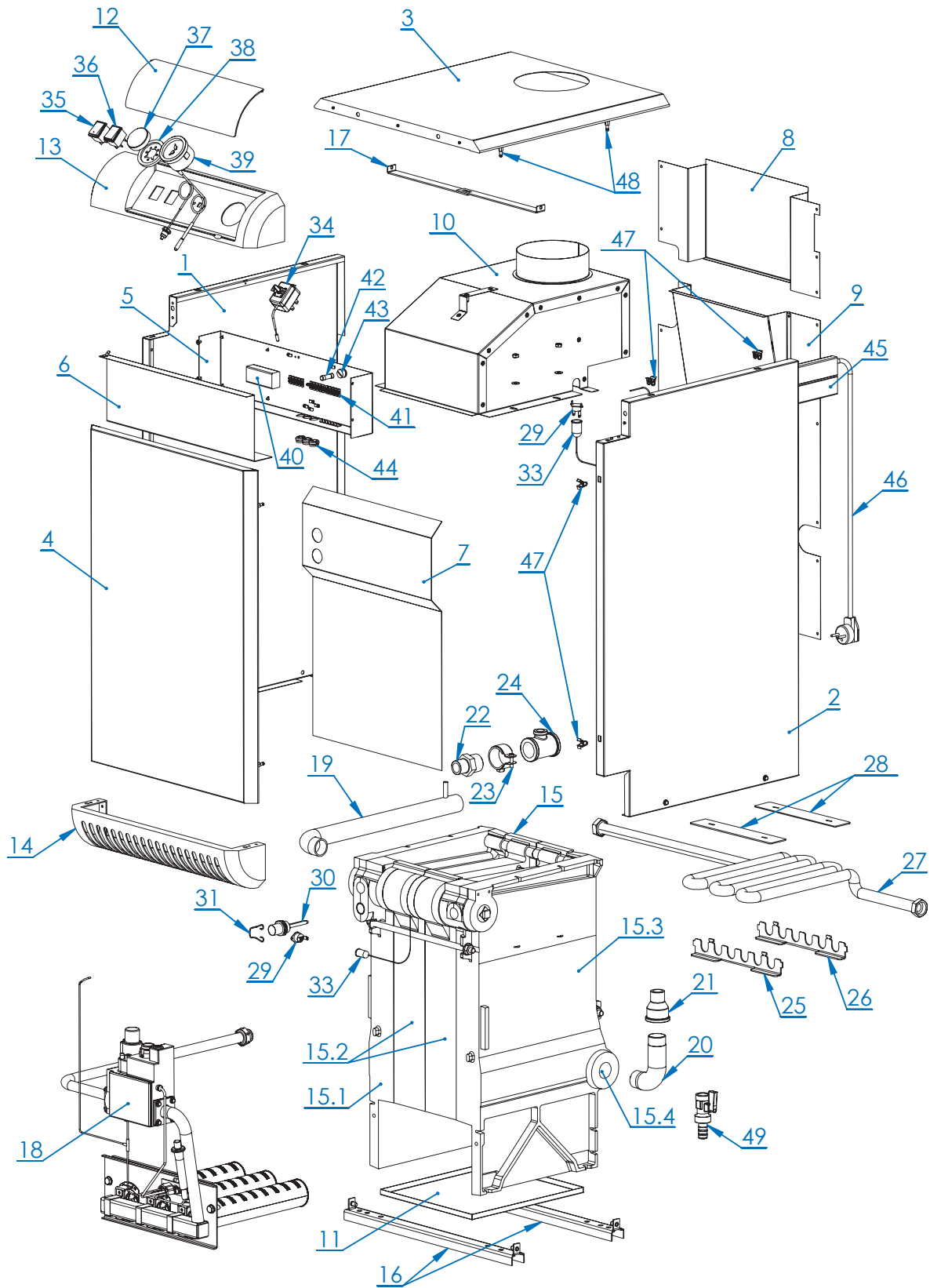

#	CODE	[kW]	TYPE	#	CODE	[kW]	TYPE
1	TS001D	12-30	EKO, PLQ, KLV, KLQ, E COMBI	23	TS557	12-30	EKO, PLQ, KLV, KLQ, E COMBI
2	TS002B	12-30	EKO, PLQ, KLV, KLQ, E COMBI	24	TS554	12-30	EKO, PLQ, KLV, KLQ, E COMBI
3	TS008A	12,15,20	EKO, PLQ, KLV, KLQ, E COMBI	25	TS080	12,15,20	EKO, PLQ, KLV, KLQ, E COMBI
	TS009	25,30	EKO, PLQ, KLV, KLQ, E COMBI		TS079	25,30	EKO, PLQ, KLV, KLQ, E COMBI
4	TS013	12,15,20	EKO, PLQ, KLV, KLQ, E COMBI	26	TS080A	12,15,20	EKO, PLQ, KLV, KLQ, E COMBI
	TS014	25,30	EKO, PLQ, KLV, KLQ, E COMBI		TS079A	25,30	EKO, PLQ, KLV, KLQ, E COMBI
5	TS018	12,15,20	EKO, PLQ, KLV, KLQ, E COMBI	27	TS081	12,15,20	EKO, PLQ, KLV, KLQ, E COMBI
	TS019	25,30	EKO, PLQ, KLV, KLQ, E COMBI		TS082	25,30	EKO, PLQ, KLV, KLQ, E COMBI
6	TS018A	12,15,20	EKO, PLQ, KLV, KLQ, E COMBI	28	TS224	12,15,20	EKO, PLQ, KLV, KLQ, E COMBI
	TS019A	25,30	EKO, PLQ, KLV, KLQ, E COMBI		TS223	25,30	EKO, PLQ, KLV, KLQ, E COMBI
7	TS024	12,15,20	EKO, PLQ, KLV, KLQ, E COMBI	29	TS215A	12-30	EKO, PLQ COMBI
	TS025	25,30	EKO, PLQ, KLV, KLQ, E COMBI		TS215	12-30	EKO, PLQ, KLV, KLQ, E COMBI
8	TS035C	12,15,20	EKO, PLQ, KLV, KLQ, E COMBI		TH27A	12,15,20	EKO, PLQ, KLV, KLQ, E COMBI
	TS036B	25,30	EKO, PLQ, KLV, KLQ, E COMBI	30	TS102	12-30	EKO, PLQ, KLV, KLQ, E COMBI
9	TS041C	12,15,20	EKO, PLQ, KLV, KLQ, E COMBI	31	TS106	12-30	EKO, PLQ, KLV, KLQ, E COMBI
	TS042C	25,30	EKO, PLQ, KLV, KLQ, E COMBI	32	OT11	12-30	EKO, PLQ, KLV, KLQ, E COMBI
10	TS030C	12,15,20	EKO, PLQ, KLV, KLQ, E COMBI	33	TH19	12-30	EKO, PLQ, KLV, KLQ, E COMBI
	TS031C	25,30	EKO, PLQ, KLV, KLQ, E COMBI	34	TH21	15,20,25	E COMBI
11	TS047	12,15,20	EKO, PLQ, KLV, KLQ, E COMBI		DPD25008A	12-30	EKO, PLQ, KLV, KLQ COMBI
	TS048	25,30	EKO, PLQ, KLV, KLQ, E COMBI	35	TS095	12-30	EKO, PLQ, KLV, KLQ, E COMBI
12	TS083	12-30	EKO, PLQ, KLV, KLQ, E COMBI	36	TS096A	15-30	PLQ, KLQ COMBI
13	TS084	12,15,20	EKO, PLQ, KLV, KLQ, E COMBI	37	TH24C	12-30	EKO, PLQ, KLV, KLQ COMBI
	TS085	25,30	EKO, PLQ, KLV, KLQ, E COMBI		TH24D	15,20,25	E COMBI
14	TS087	12,15,20	EKO, PLQ, KLV, KLQ, E COMBI	38	TS098P	12-30	EKO, PLQ, KLV, KLQ, E COMBI
	TS088	25,30	EKO, PLQ, KLV, KLQ, E COMBI	39	TS099	12-30	EKO, PLQ, KLV, KLQ, E COMBI
15	TS062	12,15,20	EKO, PLQ, KLV, KLQ, E COMBI	40	TS092A	12-30	EKO, PLQ, KLV, KLQ, E COMBI
	TS063	25,30	EKO, PLQ, KLV, KLQ, E COMBI	41	TS190	15,20,25	E COMBI
15.1	TS146	12-30	EKO, PLQ, KLV, KLQ, E COMBI		TS191	12-30	EKO COMBI
15.2	TS147	12-30	EKO, PLQ, KLV, KLQ, E COMBI		TS193	15-30	KLQ COMBI
15.3	TS145	12-30	EKO, PLQ, KLV, KLQ, E COMBI		TS194	12-30	KLQ COMBI
15.4	SR47B	12-30	EKO, PLQ, KLV, KLQ, E COMBI		TS195	15-30	PLQ COMBI
16	TS052	12,15,20	EKO, PLQ, KLV, KLQ, E COMBI	42	TH06	12-30	EKO, PLQ, KLV, KLQ, E COMBI
	TS053	25,30	EKO, PLQ, KLV, KLQ, E COMBI	43	TH05A	12-30	EKO, PLQ, KLV, KLQ, E COMBI
17	TS140A	12,15,20	EKO, PLQ, KLV, KLQ, E COMBI	44	TS094	12-30	EKO, PLQ, KLV, KLQ, E COMBI
	TS140B	25,30	EKO, PLQ, KLV, KLQ, E COMBI	45	TS107	12-30	EKO, PLQ, KLV, KLQ, E COMBI
18	Page 2/2			46	TS091	12-30	EKO, PLQ, KLV, KLQ, E COMBI
19	TS067B	12-30	EKO, PLQ, KLV, KLQ, E COMBI	47	TS122	12-30	EKO, PLQ, KLV, KLQ, E COMBI
20	TS068	12-30	EKO, PLQ, KLV, KLQ, E COMBI	48	TS123	12-30	EKO, PLQ, KLV, KLQ, E COMBI
21	TS555	12-30	EKO, PLQ, KLV, KLQ, E COMBI	49	TS103	12-30	EKO, PLQ, KLV, KLQ, E COMBI
22	TS556	12-30	EKO, PLQ, KLV, KLQ, E COMBI				

#	CODE	[kW]	TYPE
50	AU4600C	12-30	EKO COMBI
	AU4600Q	15-30	PLQ COMBI
	AU4100C	12-30	KLV COMBI
	AU4100Q	15-30	KLQ, E COMBI
51	AU4600T	12-30	EKO, PLQ COMBI
	AU4100T	12-30	KLV, KLQ, E COMBI
52	EL4100	12-30	KLV, KLQ, E COMBI
	EL4100A	12-30	KLV, KLQ, E COMBI
53	AU4600K	12-30	EKO, PLQ COMBI
54	HZ01	12-30	EKO, PLQ, KLV, KLQ, E COMBI
55	HZ29	12-30	EKO, PLQ COMBI
	HZ86	12-30	KLV, KLQ, E COMBI
56	HZ30	12-30	EKO, PLQ COMBI
	HZ86D	12-30	KLV, KLQ, E COMBI
57	HZ33	12-25	EKO, PLQ, KLV, KLQ, E COMBI
	HZ34	20-30	EKO, PLQ, KLV, KLQ, E COMBI
58	TE01	12-30	EKO, PLQ COMBI
	HZ86C	12-30	KLV, KLQ, E COMBI
59	HZ28	12-30	EKO, PLQ COMBI
60	HZ27	12-30	EKO, PLQ COMBI
61	HZ04	12-20	EKO, PLQ COMBI
	HZ05	12-20	KLV, KLQ, E COMBI
	HZ06	25-30	EKO, PLQ COMBI
	HZ07	25-30	KLV, KLQ, E COMBI
62	HZ26B	12-30	EKO, PLQ, KLV, KLQ, E COMBI
63	HZ71	12-20	EKO, PLQ, KLV, KLQ, E COMBI
	HZ72	25-30	EKO, PLQ, KLV, KLQ, E COMBI
64	HZ22	12-20	EKO, PLQ COMBI
	HZ23	12-20	KLV, KLQ, E COMBI
	HZ24	25-30	EKO, PLQ COMBI
	HZ25	25-30	KLV, KLQ, E COMBI
65	HZ81	12-20	EKO, PLQ, KLV, KLQ, E COMBI
	HZ82	25-30	EKO, PLQ, KLV, KLQ, E COMBI
66	HZ38	12-30	EKO, PLQ COMBI
	HZ39	12-30	KLV, KLQ, E COMBI
67	HZ49	12-30	EKO, PLQ, KLV, KLQ, E COMBI
68	HZ58	12-30	EKO, PLQ COMBI
	HZ58A	12-30	KLV, KLQ, E COMBI
69	AT20A	12-30	EKO, PLQ, KLV, KLQ, E COMBI

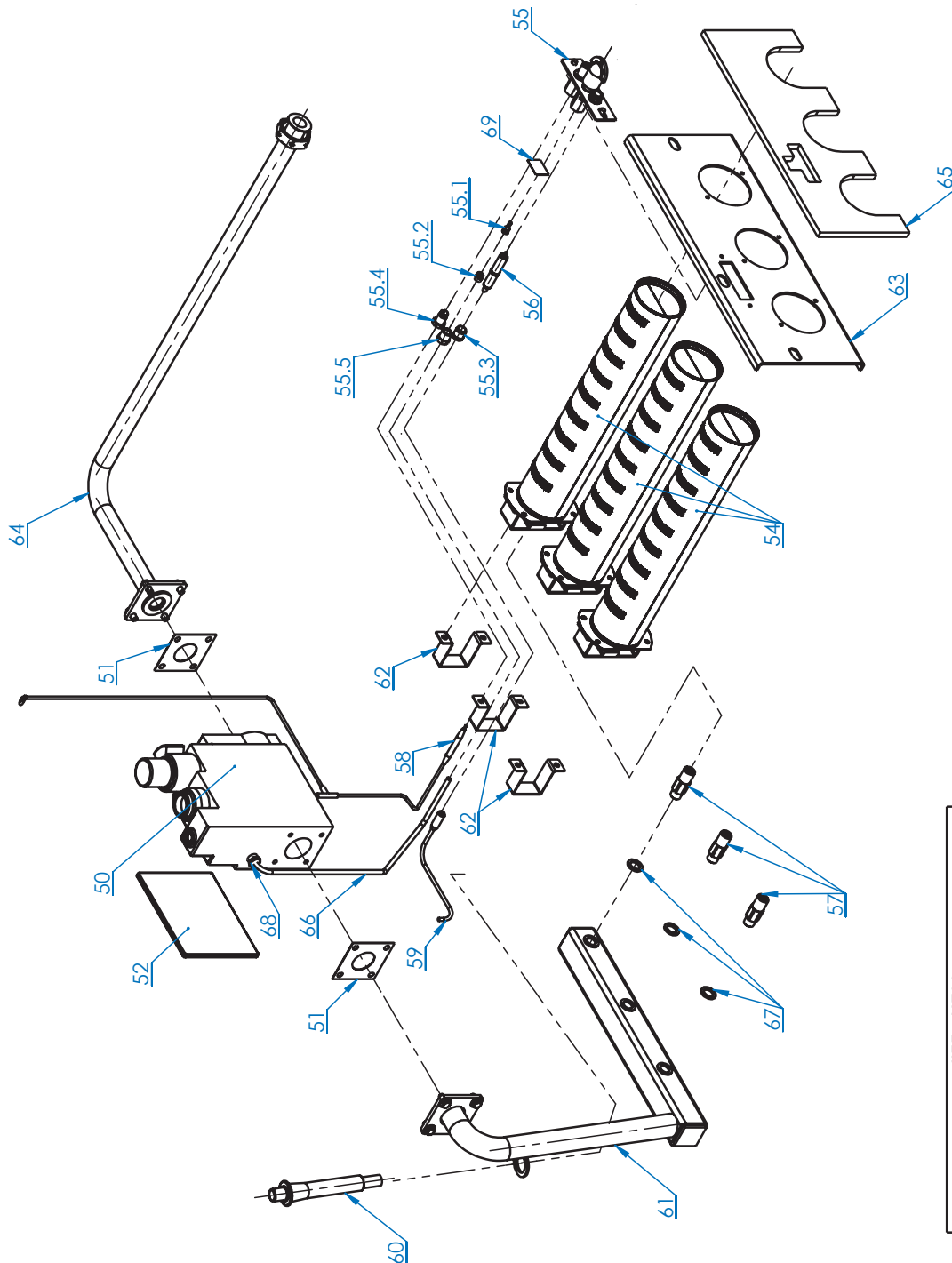

#	CODE	[kW]	TYPE
#55 - HZ86			
55.1	HZ86E	9-50	KLV, KLQ, E COMBI
55.2	HZ86A	9-50	KLV, KLQ, E COMBI
55.5	HZ86B	9-50	KLV, KLQ, E COMBI

#	CODE	[kW]	TYPE
#55 - HZ29			
55.1	HZ59	9-50	EKO, PLQ COMBI
55.2	HZ59A	9-50	EKO, PLQ COMBI
55.3	HZ59B	9-50	EKO, PLQ COMBI
55.4	HZ59C	9-50	EKO, PLQ COMBI
55.5	HZ59D	9-50	EKO, PLQ COMBI

#	CODE	kW	TYPE
1	TS062	12,15,20	PLQCV,KLQCV,EZCV,KLVCV,EKOCV/ECV
	TS063	25,30	PLQCV,KLQCV,EZCV,KLVCV,EKOCV/ECV
1.1	TS145		
1.2	TS147		
1.3	TS146		
1.4	SR47B		
<b>2</b>			<b>PAGE 80</b>
	TS215A		EKOCV,PLQCV
3	TS215B		ECV,KLVCV,EZCV,KLQCV
4	TS102		
5	TS106		
6	TS569	20, 12	
	TS568	25, 30	
7	TS067B		
8	TS024	20, 12	
	TS025	25, 30	
9	TS567		
	TS018A	20, 12	EKOCV/ECV,KLVCV,PLQCV,KLQCV
	TS019A	25, 30	
10	TS538	15, 20	
	TS540	25, 30	
11	RZ23		EZCV
12	TS095		
	TH24C		EKOCV,KLVCV,PLQCV,KLQCV
13	TH24D		ECV
14	TS098P		KLQCV,EKOCV,KLVCV,PLQCV/ECV
	TS097B		PLQCV,KLQCV,EKOCV,KLVCV,
15	TH21		ECV
16	TS099		
17	RZ41C		
18	RZ24		EZCV
	TS084	20, 12	
	TS085	25, 30	PLQCV/ECV,KLQCV,EKOCV,KLVCV/ECV
19	TS225	15, 20	
	TS226	25, 30	
20	TS083		
	TS191		EKOCV
	TS195		PLQCV
21	TS197A		EZCV
	TS190		ECV
	TS193		KLQCV
	TS194		KLQCV
22	TS008A	20, 12	
	TS009	25, 30	
23	TS913	20, 12	
	TS912	25, 30	
	TS035C	20, 12	
24	TS036B	25, 30	

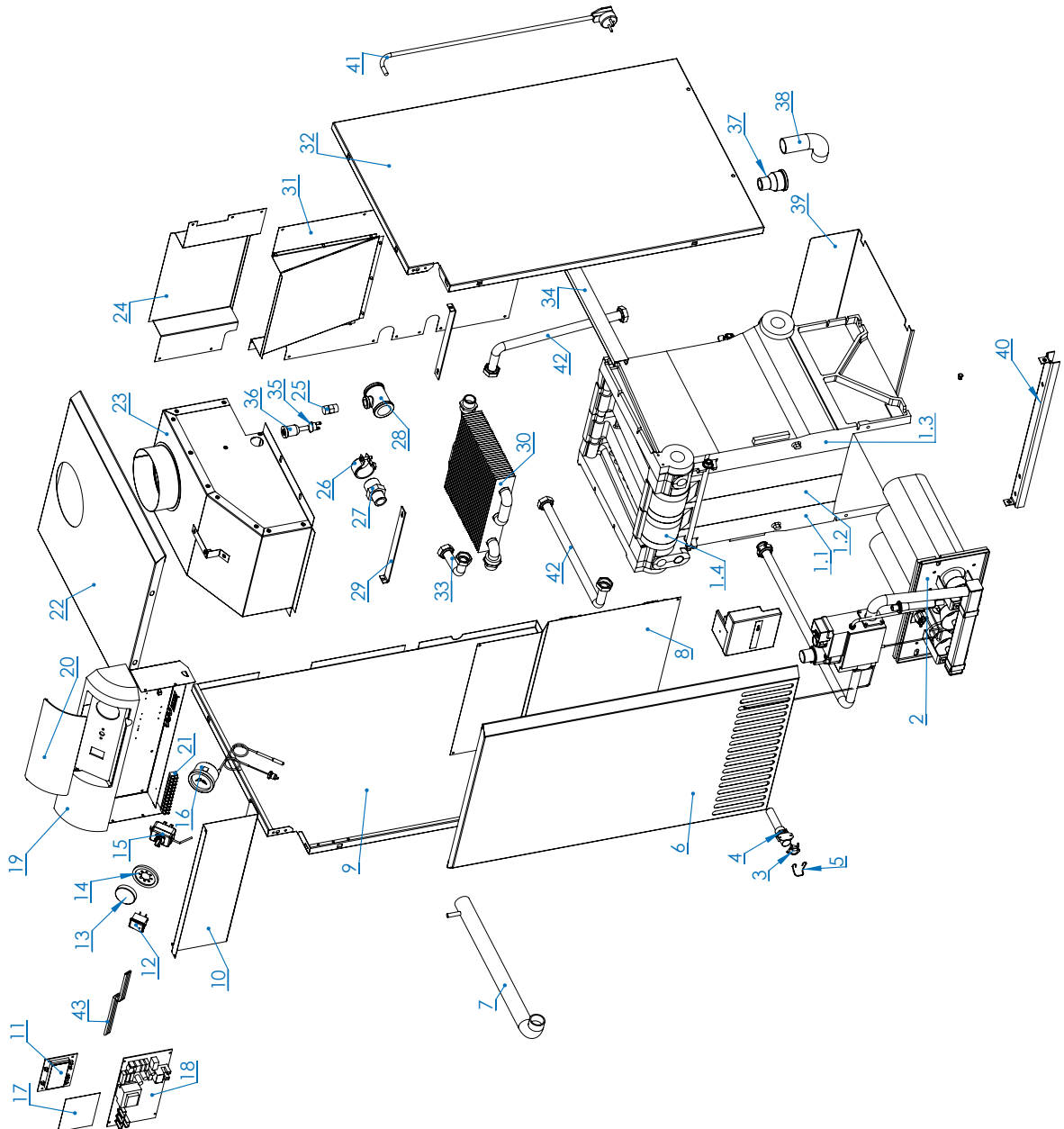

#	CODE	kw	TYPE
25	BL27A		
26	TS557		
27	TS556		
28	TS554A		
29	TS140A	20, 12	
29	TS140B	25, 30	
30	TS570	20, 12	
30	TS571	25, 30	
31	TS041C	20, 12	
31	TS042C	25, 30	
32	TS566		
33	TS169	20, 12	
33	TS168	25, 30	
34	TS107		
35	TH27A	12, 15	
35	TS215B	20, 30	
36	TH19		
37	TS555		
38	TS068		
39	HZ154	20, 12	
39	HZ140	25, 30	
40	TS052	20, 12	
40	TS053	25,30	
41	TS091		
42	TS168		
43	RZ21A		EZCV

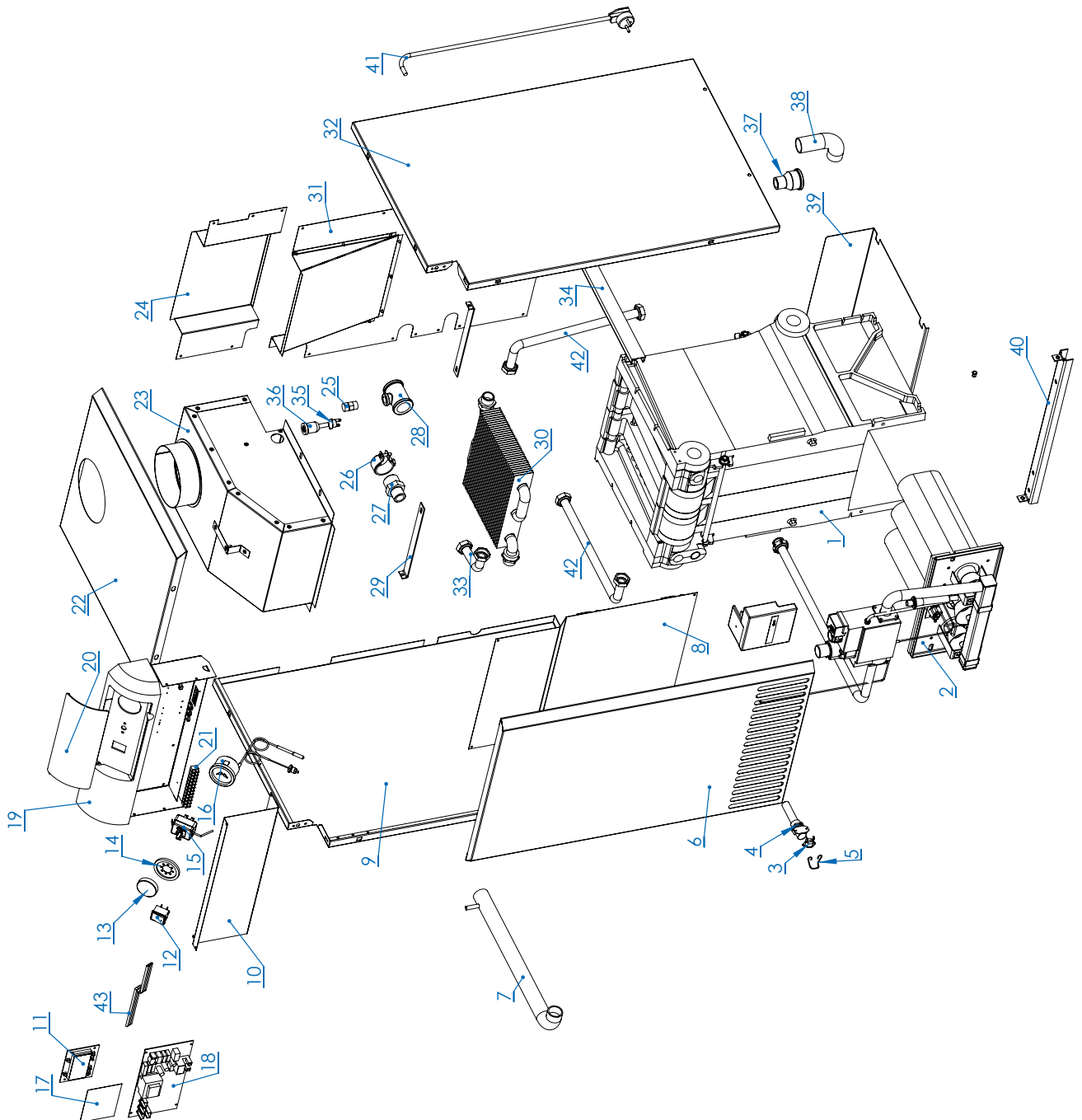

#	CODE	kW	TYPE
1	HZ158	20, 12	EKOCV,PLQCV
	HZ153	25, 30	
	HZ157	20, 12	
	HZ148	25, 30	
2	HZ27		EKOCV,PLQCV
	AU4600T		
3	AU4100T		KLVCV,KLQCV,ECV,EZCV
	HZ38	20, 12	
4	HZ38A	25, 30	EKOCV,PLQCV
	HZ39	20, 12	
	HZ39A	25, 30	
	TE01		
6	HZ28A		EKOCV,PLQCV
7	HZ58		
8	AU4600K		EKOCV
	AU4600C		
	AU4600Q		
	AU4100C		
9	AU4105M		KLVCV,KLQCV,ECV EZCV
	HZ22	20, 12	
10	HZ24	25, 30	EKOCV,PLQCV
	HZ23	20, 12	
	HZ25	25, 30	
	HZ93	15, 20	
	HZ87	25, 30	
	HZ30		
12	HZ49		EKOCV,PLQCV
13	HZ33	25, 12	
	HZ34	30	
14	HZ59C		EKOCV,PLQCV
15	HZ59D		EKOCV,PLQCV

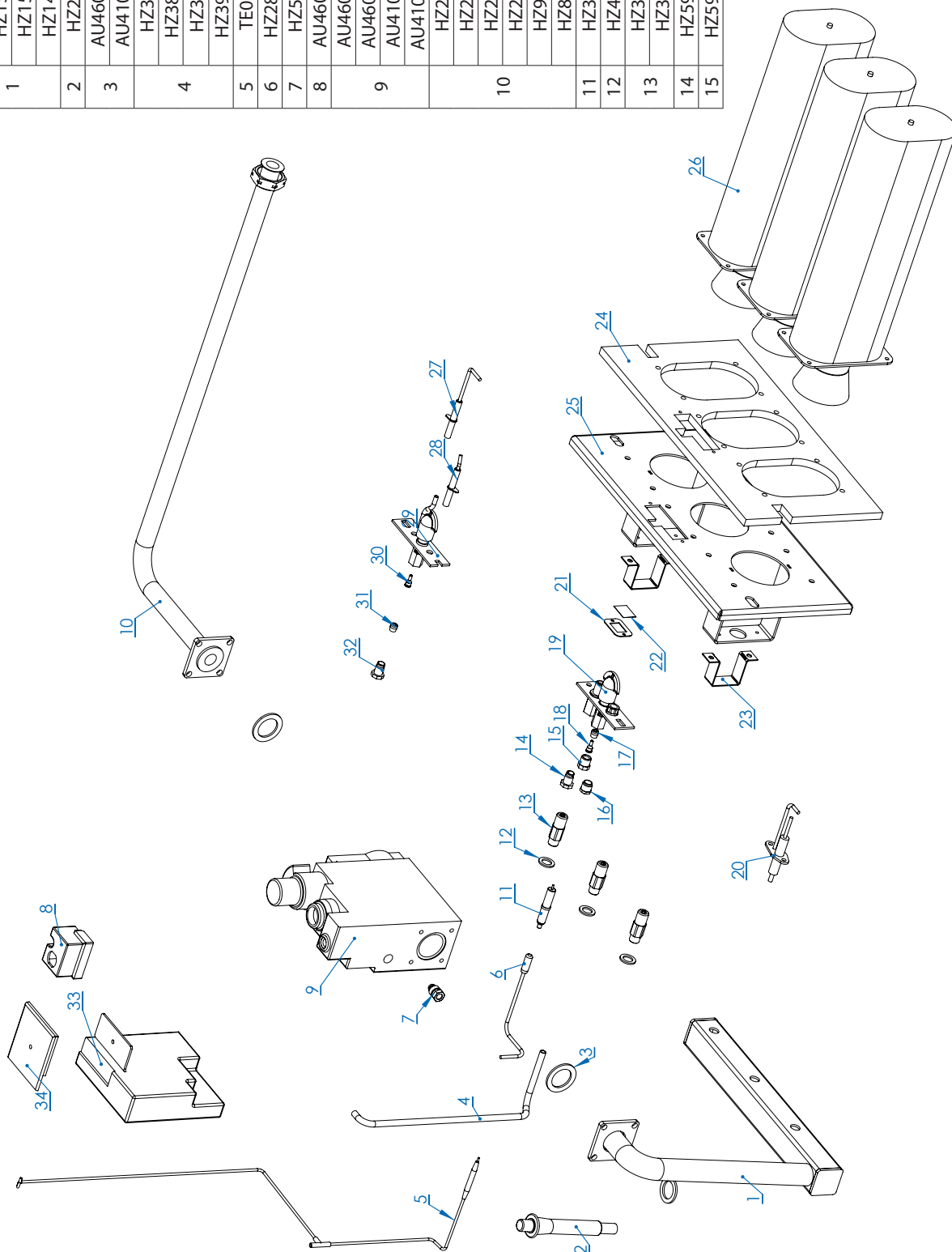

#	CODE	KW	TYPE
16	HZ59B		EKOCV,PLQCV
17	HZ59A		
18	HZ59		
19	HZ29		
20	HZ130		EZCV
21	HZ132		
22	AT20A		
23	HZ147		EKOCV,PLQCV, KLVCV,KLQCV
24	HZ192	20, 12	
	HZ193	25, 30	
	HZ156	15, 20	
	HZ142	25, 30	EZCV
	HZ188	20, 12	
	HZ190	25, 30	
	HZ161A	15, 20	
25	HZ159A	25, 30	KLVCV,KLQCV,ECV
26	HZ163		
27	HZ86C		
28	HZ86D		
29	HZ86		KLVCV,KLQCV,ECV
30	HZ86E		
31	HZ86A		
32	HZ86B		
33	EL4100		KLVCV,KLQCV,ECV
34	EL4100A		

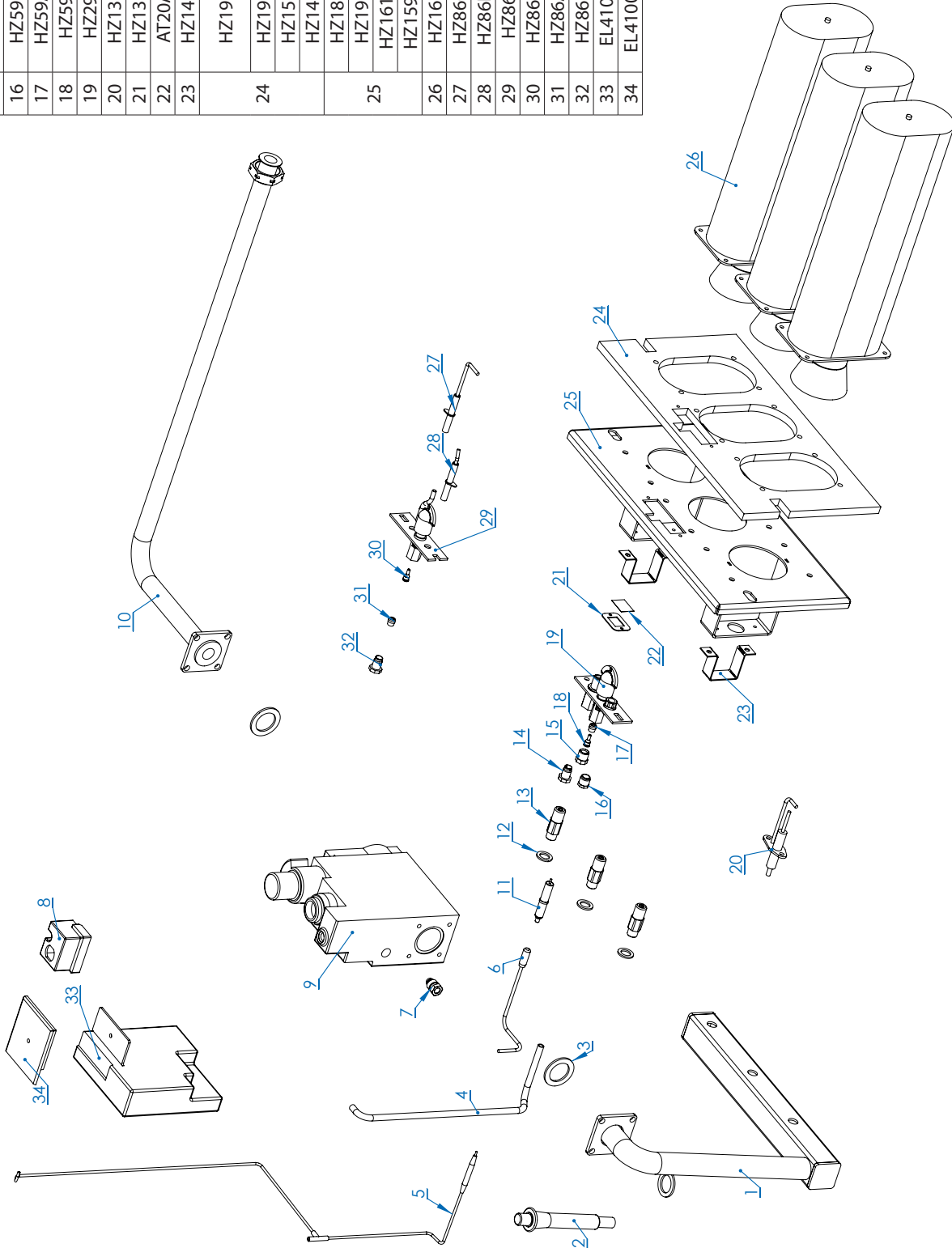

#	CODE	TYPE
1	SV02	TURBO20
	SV03	TURBO30
	SV04	TURBO35
	SV05	TURBO45
	SV06	TURBO50
	SV07	TURBO20
2	SV08	TURBO30,TURBO35
	SV09	TURBO45,TURBO50
3	SV13	
4	SV15	
5	TS094	
6	PR15	
7	SV10	
8	SV11D	
9	SV01B	

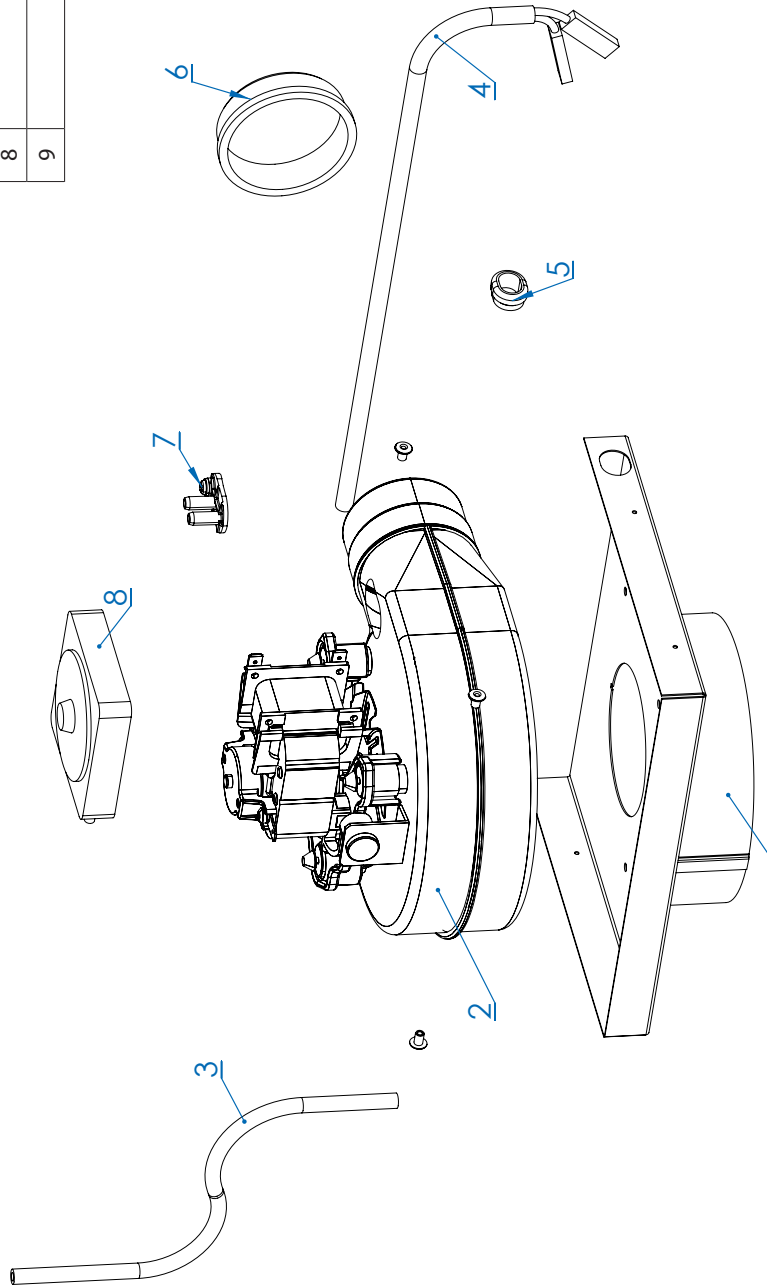
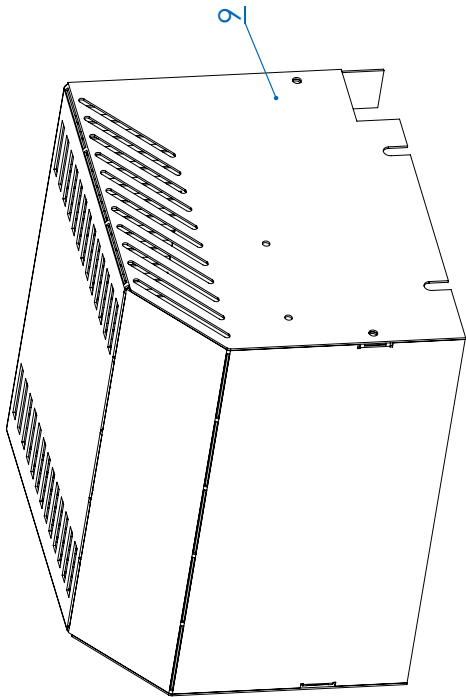

#	CODE	RW	TYPE
1	SM103	12, 15, 20	
	SM104	25, 30	
1.1	SM108		
1.2	SM109		
1.3	SM110		
2			PAGE 101
3	TS653	12, 15, 20	
	TS599	25, 30	
4	TS923	12, 15, 20	
	TS930	25, 30	
5	TS102		
6	TS215A		EKOCV, PLOCV
	TS215B		KLOCV, KLVCV, ECV
7	TS106		
8	OT11		
9	HZ218		
10	TS659		
11	TS600		
12	TS655		
13	TS656		
14	TS657		
15	TS654		
16	TS616		
17	TS617		
18	HZ226	12, 15, 20	
	HZ227	25, 30	
19	TH27A	12, 15	
	TS215B	20, 25, 30	
20	TH19		
21	TS091		
22	TS083		
23	TS084	12, 15, 20	
	TS085	25, 30	
24	TS569	12, 15, 20	
	TS568	25, 30	
25	TS603	12, 15, 20	
	TS614	25, 30	
26	TS934A	12, 15, 20	
	TS933A	25, 30	
27	TS632		
28	HZ205	12, 15, 20	
	HZ200	25, 30	
29	TS607		
30	TS608		
31	TS609	12, 15, 20	
	TS601	25, 30	
32	TS611	12, 15, 20	
	TS606	25, 30	
33	TS018	12, 15, 20	
	TS019	25, 30	
34	TS018A	12, 15, 20	
	TS019A	25, 30	
35	TS141A	12, 15, 20	
	TS141	25, 30	
36	TH05A		
37	TH06		
38	TS095		
39	TS099		
40	TS098P		
41	TH24C		EKOCV, KLOCV, KLVCV, PLOCV
	TH24D		ECV
42	TS097B		EKOCV, KLOCV, KLVCV, PLOCV
	TH21		ECV
	TS190		ECV
	TS191		EKOCV
	TS193		KLOCV
43	TS194		KLVCV
	TS195		PLOCV

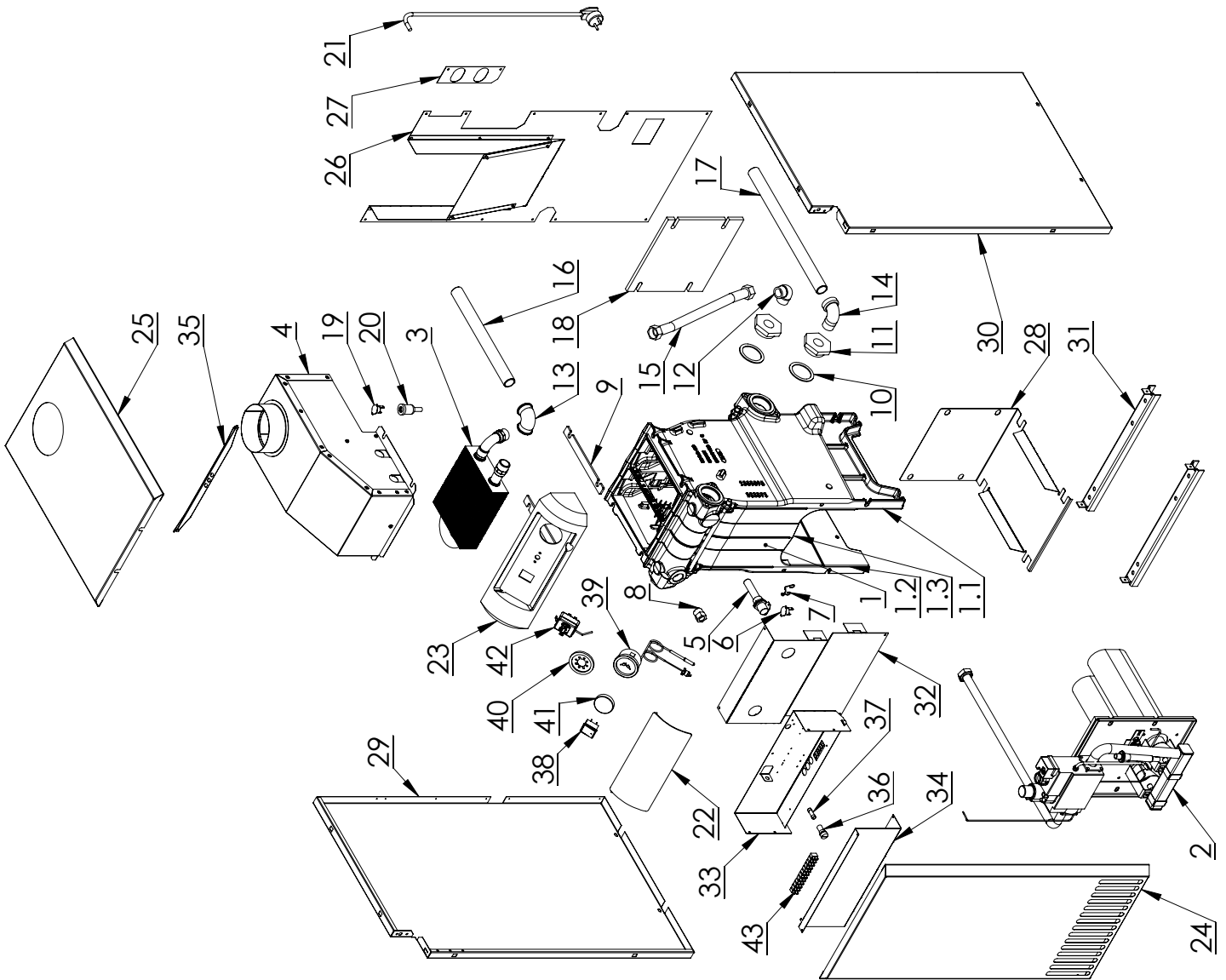

#	CODE	KW	TYPE
1	HZ158	12, 15, 20	EKOCV, PLOCV
	HZ153	25, 30	
	HZ157	12, 15, 20	KLOCV, KLVCV, ECV
2	HZ148	25, 30	
	HZ27		EKOCV, PLOCV
3	AU4600T		EKOCV, PLOCV
	AU4100T		KLOCV, KLVCV, ECV
4	HZ38	12, 15, 20	EKOCV, PLOCV
	HZ38A	25, 30	
	HZ39	12, 15, 20	KLOCV, KLVCV, ECV
5	HZ39A	25, 30	
	TE01		
6	HZ28	12, 15, 20	EKOCV, PLOCV
	HZ28A	25, 30	
	HZ58		
8	AU4600K		EKOCV
	AU4600C		PLOCV
9	AU4600Q		KLVCV
	AU4100C		KLOCV, ECV
	AU4100Q		
10	HZ22	12, 15, 20	EKOCV, PLOCV
	HZ24	25, 30	
	HZ23	12, 15, 20	KLOCV, KLVCV, ECV
11	HZ25	25, 30	
	HZ29		
12	HZ30		
13	HZ59		
14	HZ59A		
15	HZ59B		
16	HZ59C		
17	HZ59D		
18	HZ49		
19	HZ33	12, 15, 20, 25	
	HZ34	30	
20	AT20A		
21	HZ147		
22	HZ206	12, 15, 20	
	HZ202	25, 30	
23	HZ204A	12, 15, 20	
	HZ203A	25, 30	
24	HZ163		
25	HZ86		
26	HZ86A		
27	HZ86B		
28	HZ86C		
29	HZ86D		
30	HZ86E		
31	EL4100		
31	EL4100A		KLOCV, KLVCV, ECV

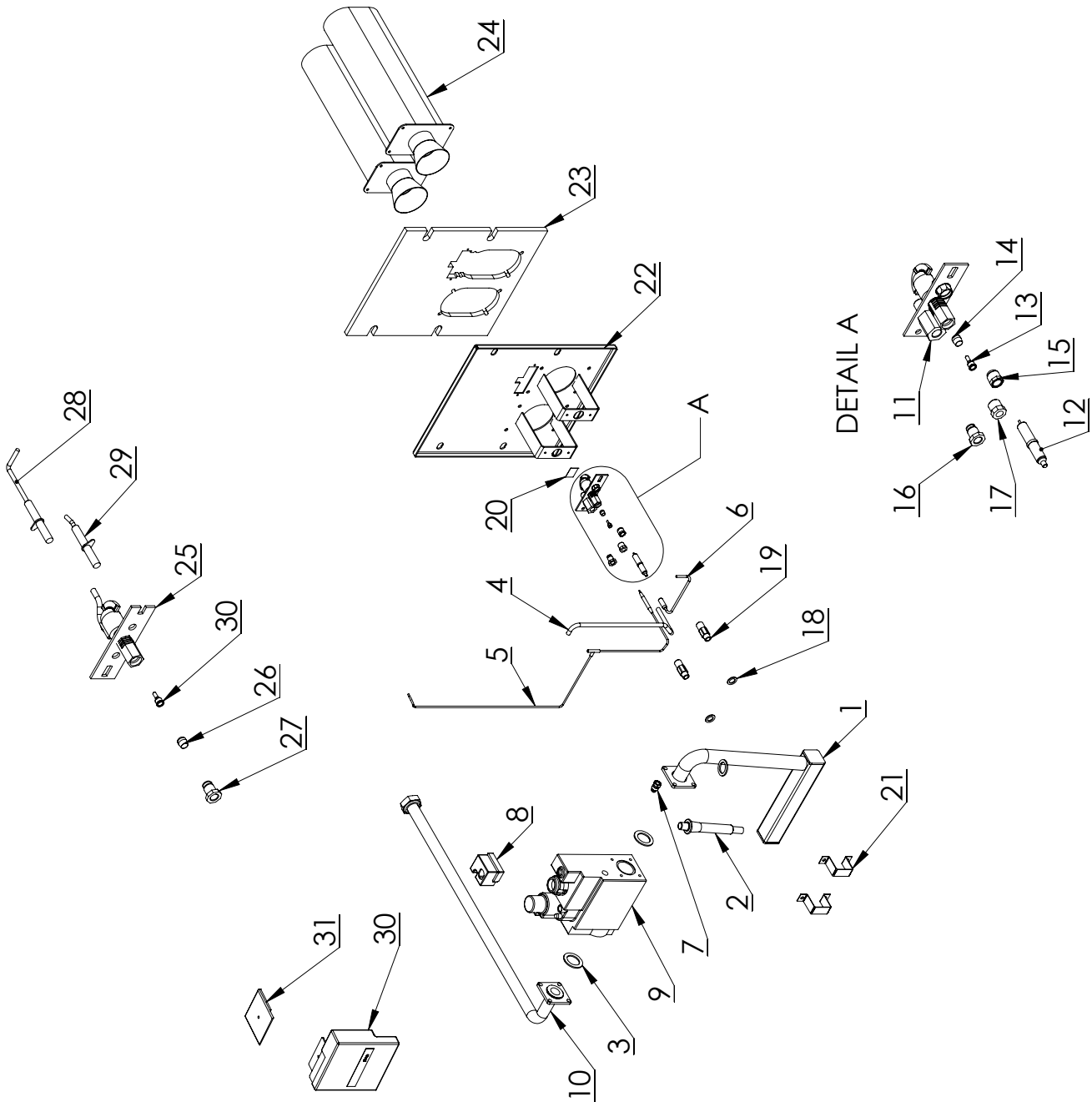

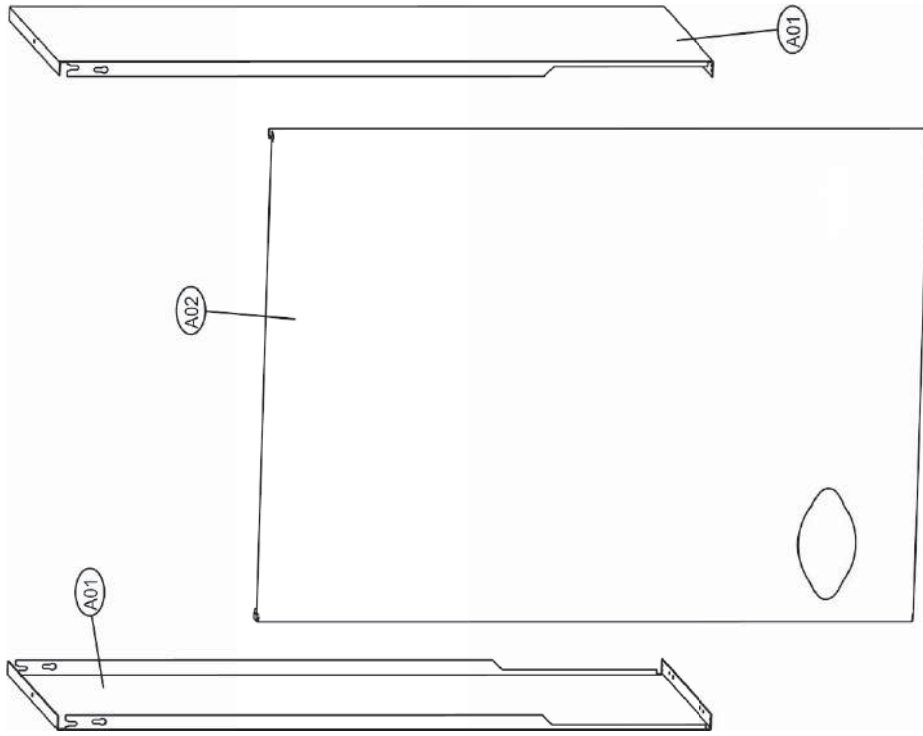

#	CODE
A01	PL141
A02	PL195

# ATTACK RZK Plus

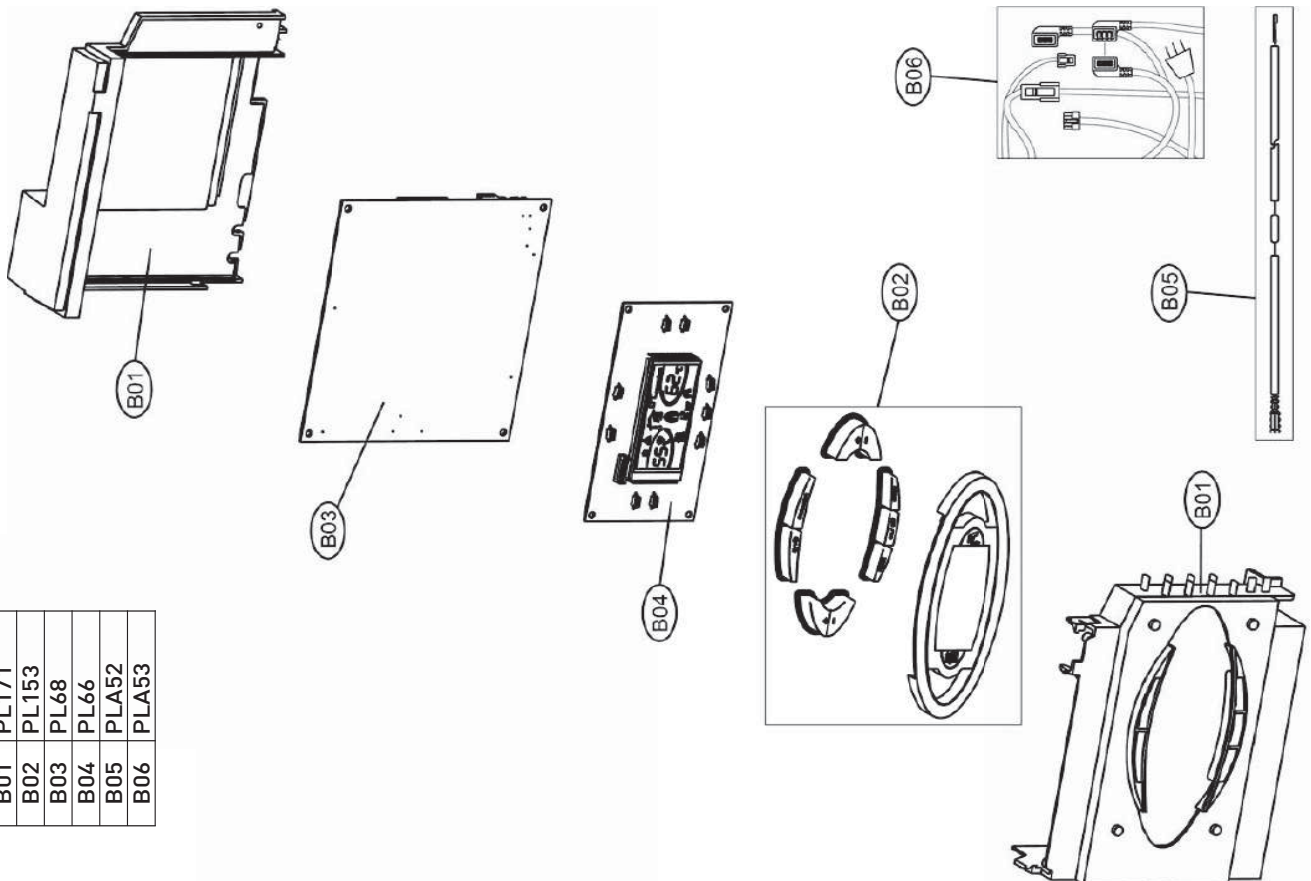

#	CODE
B01	PL171
B02	PL153
B03	PL68
B04	PL66
B05	PLA52
B06	PLA53

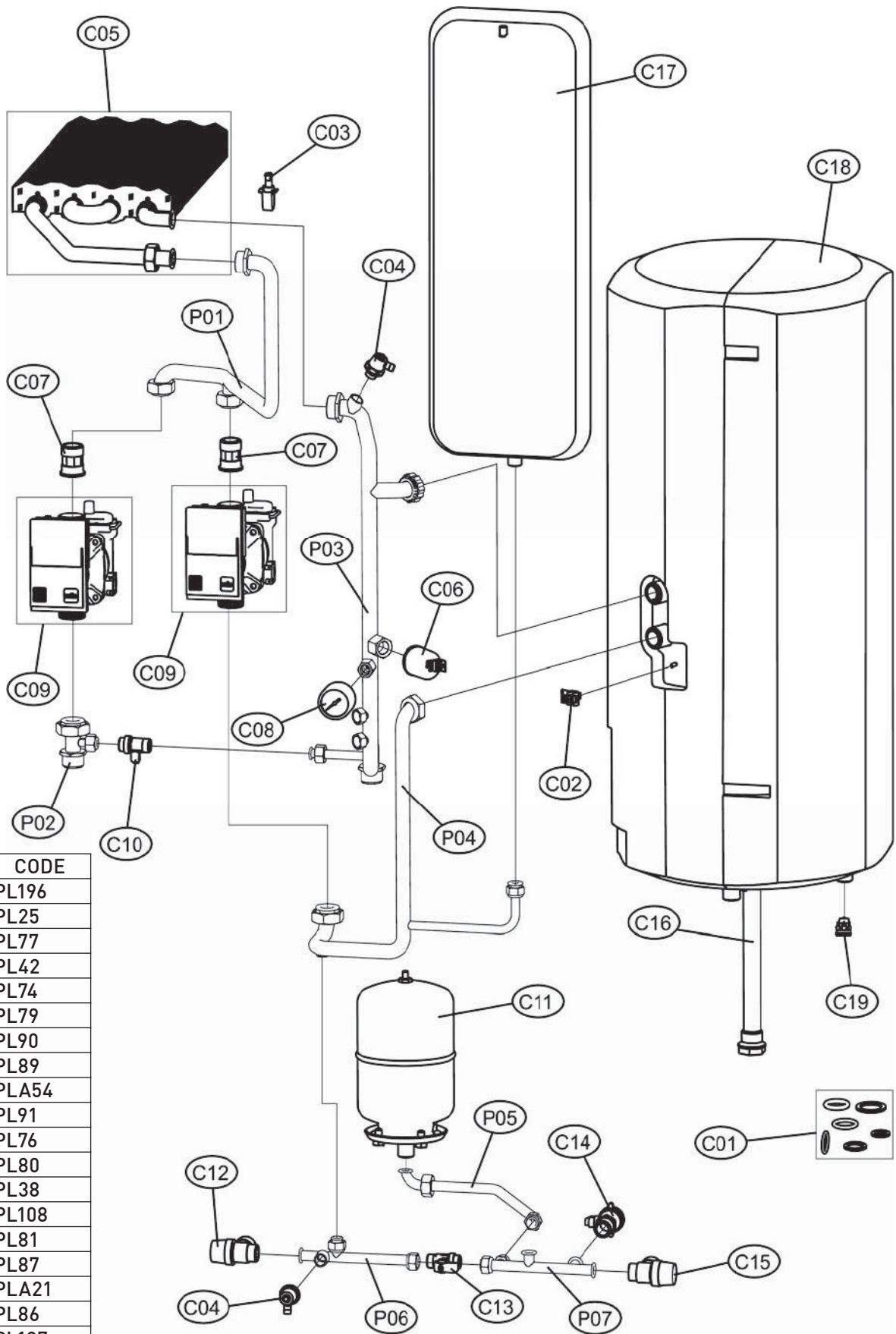

#	CODE
C01	PL196
C02	PL25
C03	PL77
C04	PL42
C05	PL74
C06	PL79
C07	PL90
C08	PL89
C09	PLA54
C10	PL91
C11	PL76
C12	PL80
C13	PL38
C14	PL108
C15	PL81
C16	PL87
C17	PLA21
C18	PL86
C19	PL107
P01	PL215
P02	PL217
P03	PLA55
P04	PL218
P05	PL219
P06	PL220
P07	PL221

#	CODE
D01	PL97
D02	PL109
D03	PL197
D04	PL106
D05	PL105
D06	PL98
D07	PL111
P08	PL222

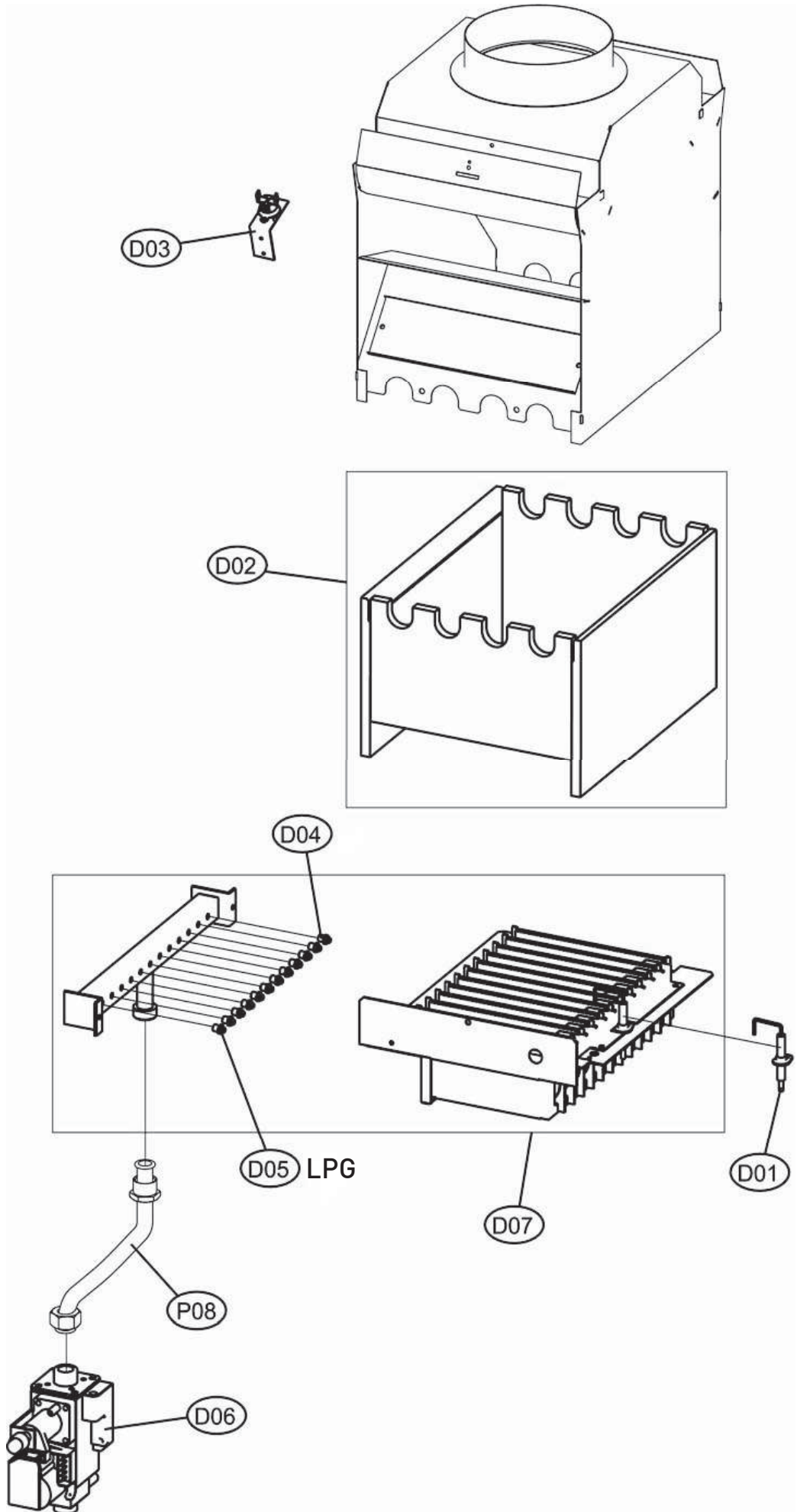

#	CODE	
	EK025	24
4	EK025A	15
	EK025B	8
5	EK026	
6	EK027	
7	EK028	
8	EK029	
9	EK030	
10	EK031	
11	EK032	
12	EK033	
13	EK034	
14	EK035	
15	EK036	
16	EK037	
17	EK038	
18	EK039	
19	EK040	
20	EK04	
21	EK04	
22	EK043	
23	EK044	do/to 10/2015
	EK102	od/from 11/2015
24	EK045	
25	EK046	
26	EK047	
27	EK048	
28	EK049	
29	EK050	
30	EK051	
47	EK068	

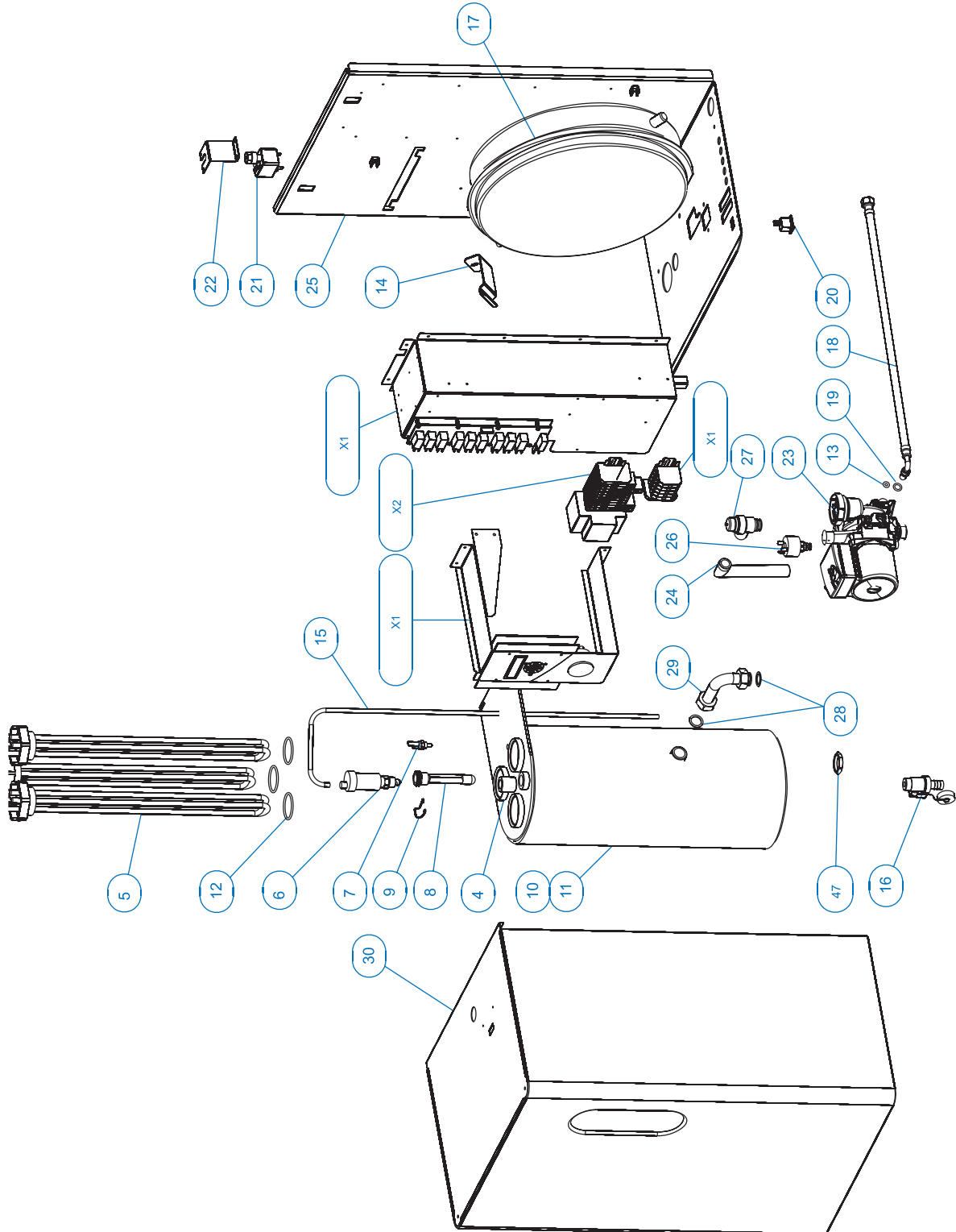

## X2

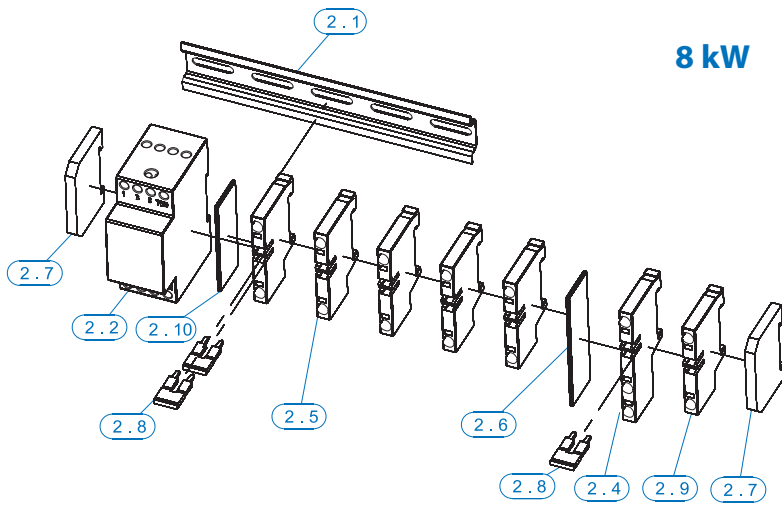

8 kW

#	CODE	
2.1	EK011	
2.2	EK012	24
2.2	EK012A	15
2.2	EK012B	8
2.3	EK013	
2.4	EK014	
2.5	EK015	
2.6	EK016	
2.7	EK017	
2.8	EK018	
2.9	EK019	
2.10	EK020	

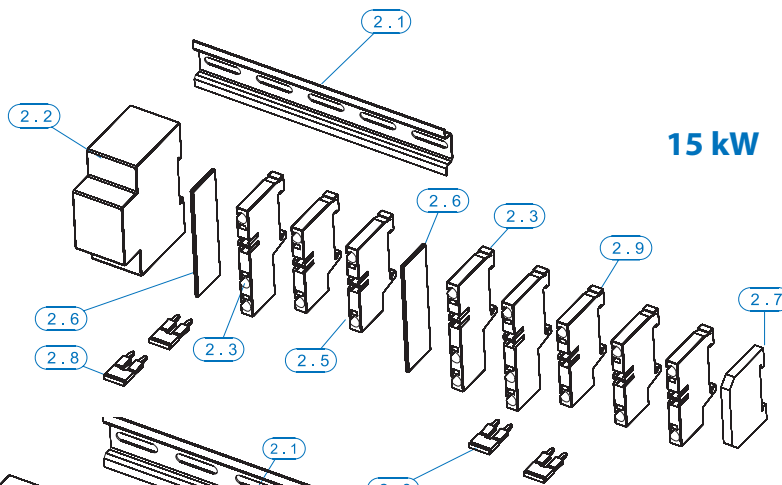

15 kW

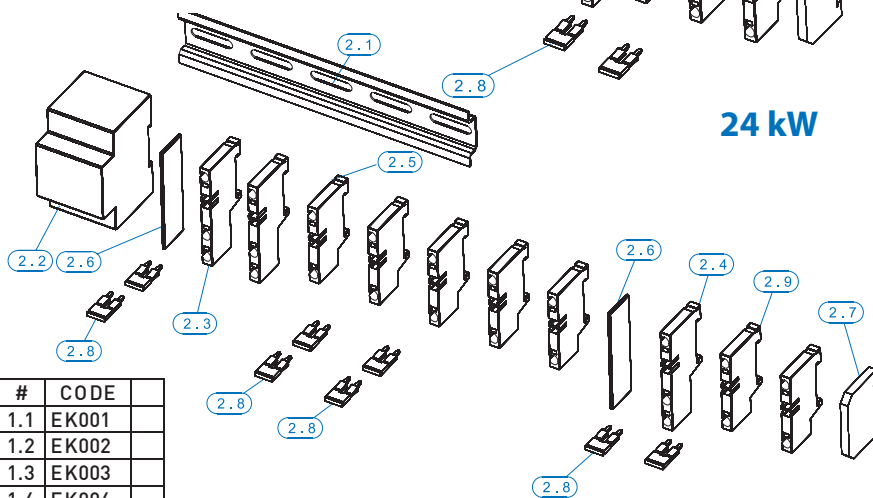

24 kW

#	CODE	
1.1	EK001	
1.2	EK002	
1.3	EK003	
1.4	EK004	
1.5	EK005	24
	EK005A	15
	EK005B	8
1.6	EK006	
1.7	EK007	
1.8	EK008	
1.9	EK009	
1.10	EK069	
1.11	EK010	
2.1	EK011	
2.2	EK012	24
2.2	EK012A	15
2.2	EK012B	8
2.3	EK013	
2.4	EK014	
2.5	EK015	
2.6	EK016	
2.7	EK017	
2.8	EK018	
2.9	EK019	

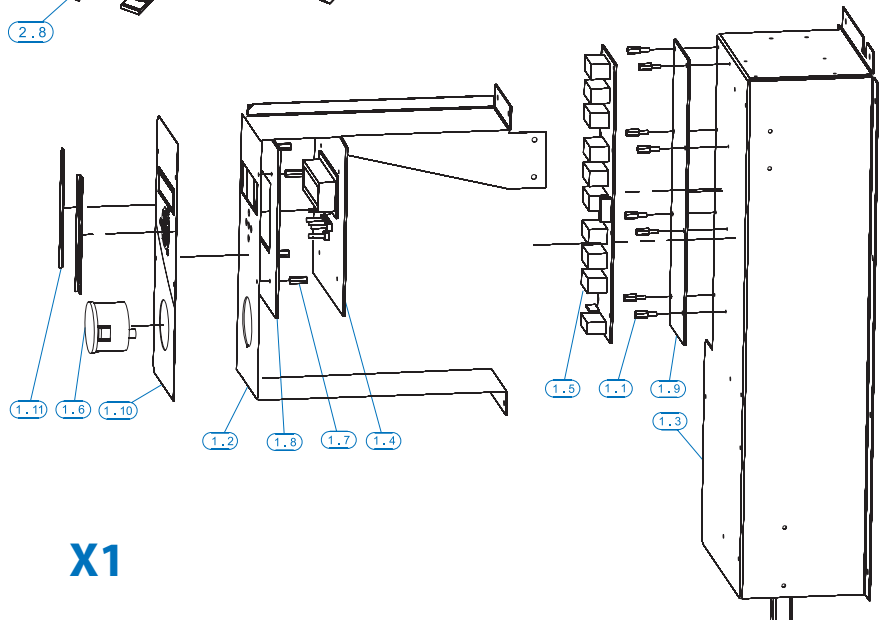

## X1

#	CODE	
1	EK074	
3	EK073	
22	EK041	
23	EK090	
24	EK042	
25	EK044	do/to 10/2015
26	EK102	od/from 11/2015
26	EK091	
27	EK092	
28	EK030	
29	EK094	
30	EK047	
33	EK048	
38	EK049	
48	EK095	
49	EK068	
53	EK050	
54	EK027	
55	EK037	
56	EK029	
57	EK096	
58	EK097	
59	EK098	
60	EK026	
61	EK099	
62	EK100	
63	EK006	
64	EK101	
65	EK022	
66	EK023	
67	EK024	
68	EK017	
69	EK012B	
70	EK093	
71	EK028	

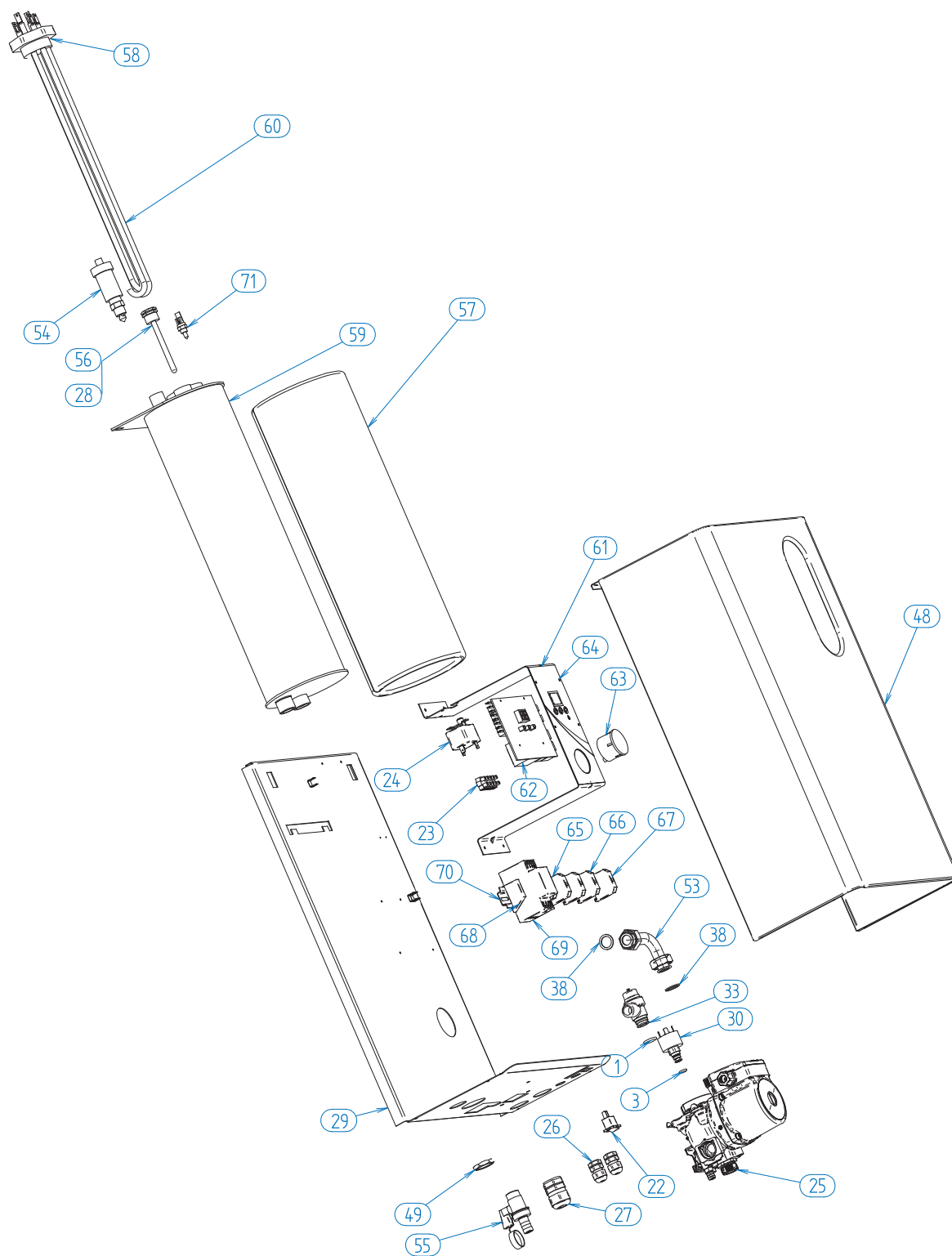

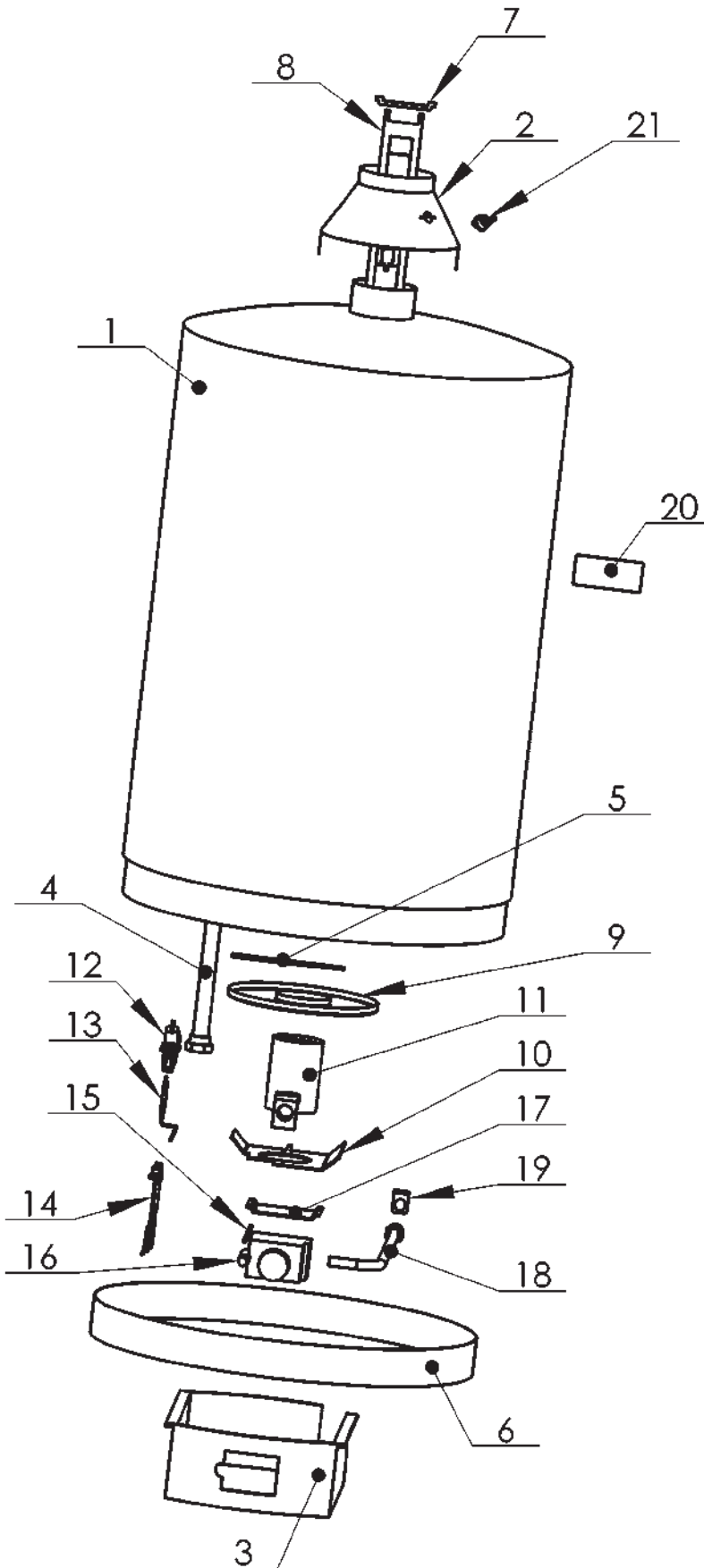

#	TYPE	CODE
1	PZO 80	PZ001C
	PZO 120	PZ002C
	PZO 150	PZ003C
2	ALL	PZ46
3	ALL	PZ39
4	PZO 80	PZ47
	PZO 120	PZ48
	PZO 150	PZ49
5	ALL	PZ50
6	ALL	PZ31
7	ALL	PZ51
8	PZO 80	PZ52
	PZO 120, 150	PZ53
9	ALL	PZ54
10	ALL	PZ55
11	PZO 80, 120	PZ56
	PZO 150	PZ57
12	ALL	PZ58
13	ALL	PZ34
14	ALL	PZ59
15	ALL	PZ60
16	ALL	PZ36
17	ALL	PZ61
18	ALL	PZ62
19	ALL	PZ63
20	ALL	PZ40
21	ALL	PZ64



#	CODE	TYPE
1	PZ001C	PZO80
	PZ002C	PZO120
	PZ003C	PZO150
2	PZ52	PZO80
	PZ53	PZO120, PZO150
3	PZ51	
4	PZ46	
5	PZ40	
6	PZ64	
7	PZ31	
8	PZ47	PZO80
	PZ48	PZO120
	PZ49	PZO150

#	CODE	TYPE
9	PZ62	
10	PZ56	PZO80, PZO120
	PZ57	PZO150
11	PZ34	
12	PZ59	
13	PZ36	
14	PZ37	

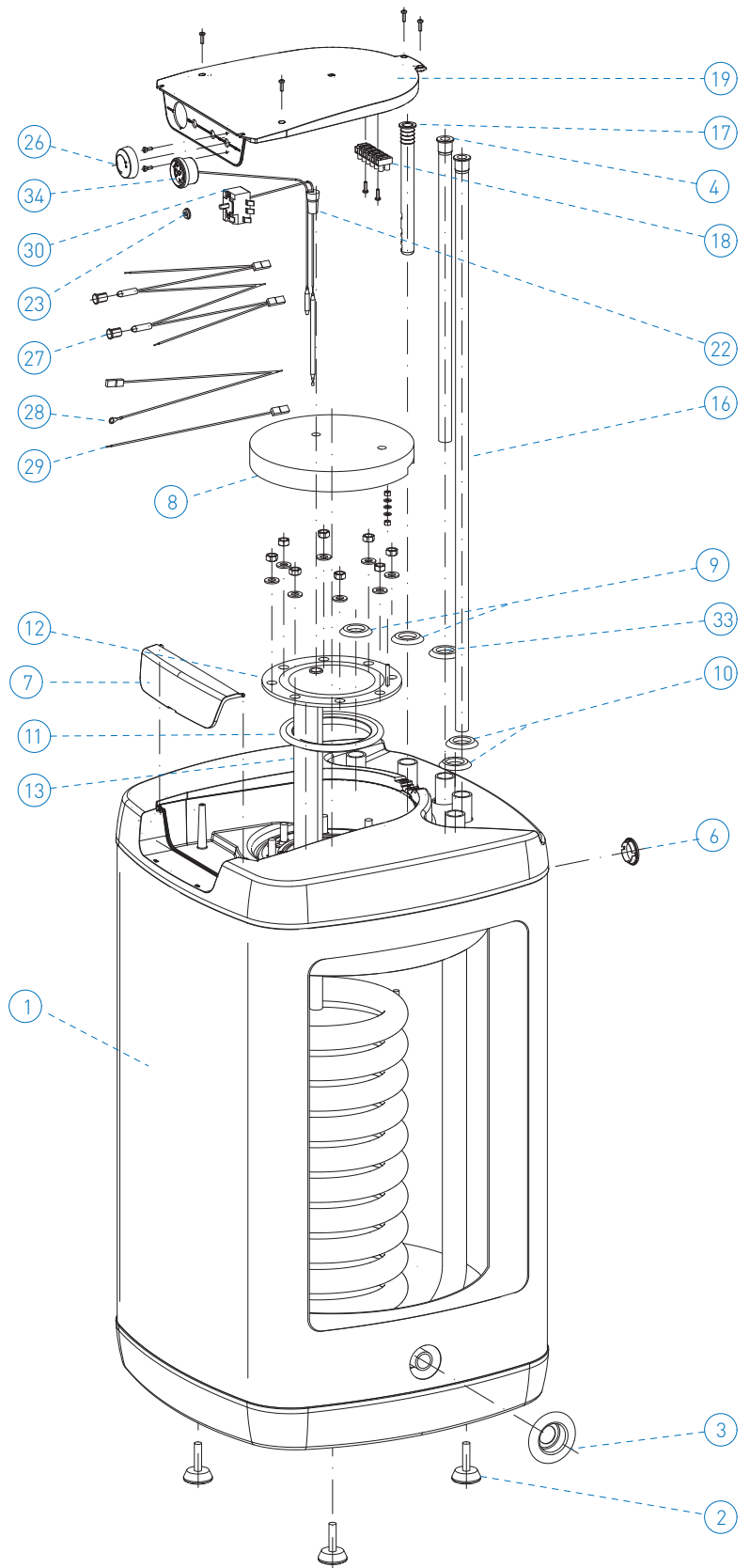
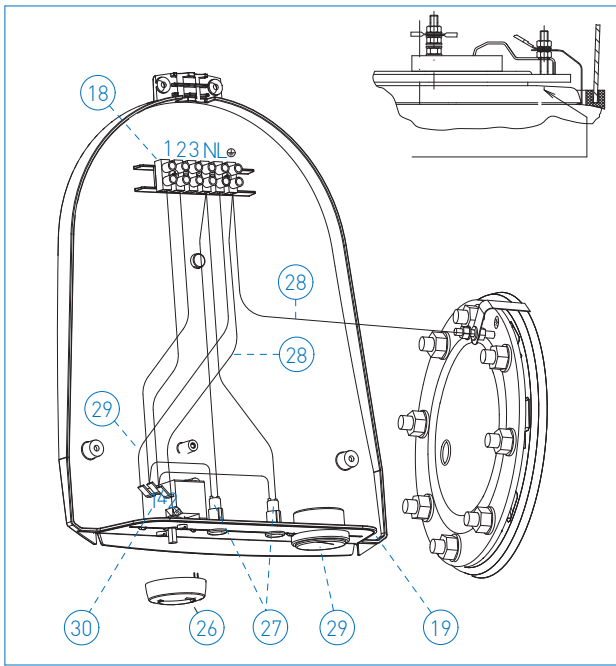

#	CODE
1	ZP001
2	ZP002
3	ZP003
4	ZP004
6	ZP005
7	ZP006
8	ZP007
9	ZP008
10	ZP009
11	ZP010
12	ZP011
13	ZP012
16	ZP013
17	ZP014
18	ZP015
19	ZP016
22	ZP017
23	ZP018
26	ZP019
27	ZP020
28	ZP021
29	ZP022
30	ZP023
33	ZP024
34	ZP025





**HEAT TECHNOLOGY MANUFACTURER**



**ATTACK, s.r.o.**  
Dielenská Kružná 5020  
038 61 Vrútky  
Slovenská republika  
+421 43 4003 101  
kotle@attack.sk



**SLOVENSKÝ VÝROBCA**



**SK:** Všetky uvedené informácie sú dočasné, podliehajú zmenám bez predchádzajúceho upozornenia a slúžia len na účely predbežného oznámenia. Možné sú odchýlky v zobrazení produktov a nemusia sa zhodovať s ponukou a s radom vybavenia pre rôzne trhy. Spoločnosť ATTACK s.r.o. si vyhradzuje právo na vykonanie zmien v špecifikáciách a v obsahu bez predchádzajúceho upozornenia. Obrázky a technické údaje k výrobkom sú len informačné. Zmena cien a ponuky vyhradená. **CZ:** Všetchny uvedené informace jsou dočasné, podléhají změnám bez předchozího upozornění a slouží pouze pro účely předběžného oznámení. Možné jsou odchylky v zobrazení produktů a nemusí se shodovat s nabídkou a s řadou vybavení pro různé trhy. Společnost ATTACK s.r.o. si vyhrazuje právo na provedení změn ve specifikacích a v obsahu bez předchozího upozornění. Obrázky a technické údaje k výrobkům jsou pouze informační. Změna cen a nabídky vyhrazena. **EN:** All provided information is temporary, subject to change without notice and for informational purposes only. Variations in product visual display are possible and may not match the offer and range of equipment for different markets. ATTACK s.r.o. reserves the right to make changes to specifications and content without prior notice. Pictures and product specifications are only informative. Price and offer changes are reserved. **DE:** Alle genannte Informationen sind einstweilig und können ohne vorherige Ankündigung geändert werden. Sie dienen nur zu Informationszwecken. Abweichungen in der Produktanzeige sind möglich und stimmen möglicherweise nicht mit dem Angebot und dem Ausstattungsspektrum für verschiedene Märkte überein. ATTACK s.r.o. behält sich das Recht vor, Änderungen an technischen Daten und Inhalten ohne vorherige Ankündigung vorzunehmen. Abbildungen und Produktspezifikationen dienen nur zur Information. Preis- und Angebotsänderung vorbehalten. **RO:** Continutul acestui site este supus actualizării fara o atenționare prealabilă și este folosit numai pentru informare. Imaginile produselor sunt prezentate cu titlu de exemplu, iar produsele pot diferi de imaginii în funcție de oferta destinată către piețe diferite. Compania ATTACK s.r.o. își rezervă dreptul de a face schimbări în specificații și continut fără o informare prealabilă. Imaginile și detaliile tehnice ale produselor sunt exclusiv pentru informare. Modificarea prețurilor și a ofertei, rezervată

**www.attack.sk**



heatingattack



kotleATTACK